

CLM cLEAN motors Operating manual

en-US
04/2024
ID 443443_en.00

Table of contents

1	User information	4
1.1	Formatting conventions	4
1.2	Limitation of liability	5
1.3	Product names and brands	5
1.4	Additional documentation	5
1.5	Copyright notice	5
2	Safety notes	6
2.1	Intended use	6
2.2	Requirements for personnel	6
2.3	Prevention of personal injury	7
2.3.1	Electrical hazards	7
2.3.2	Mechanical hazards	7
2.3.3	Thermal hazards	8
2.3.4	Hazards due to magnetic or electromagnetic fields	8
2.4	Prevention of property damage	8
2.5	Warning labels on the motor	8
3	Product description	9
3.1	Basic structure	9
3.2	Type designation	9
3.3	Nameplate	10
3.4	General features	11
3.5	Electrical features	11
3.5.1	Temperature sensor	11
3.6	Ambient conditions	12
4	Transport and storage	13
4.1	Transport	13
4.2	Storage	13
5	Installation	14
5.1	Assembly tolerances	14
5.2	Mounting the motor on a KSS gear unit	14
6	Electrical connection	17
6.1	Terminal assignment	17
6.2	Connecting the extension cable	18
6.3	Connecting the motor to the drive controller	19
6.3.1	Connection without motor disconnecting switch	19

6.3.2	Connection with motor disconnecting switch	20
7	Commissioning	21
7.1	Before commissioning	21
7.2	Parameterizing the motor	21
7.3	During commissioning	21
8	Servicing	22
8.1	Maintenance.....	22
8.1.1	Cleaning	22
8.1.2	Visual inspection	22
8.1.3	Review during operation	23
8.2	Remedying faults	23
8.3	Servicing	24
9	Removal and disposal.....	25
9.1	Removal	25
9.2	Disposal	25

1 User information

This documentation is a part of the product. It applies to products in the standard design according to the corresponding STOBER catalog.

1.1 Formatting conventions

Orientation guides in the form of signal words are used to emphasize specific information so that you are able identify it in this documentation quickly.

Safety notes indicate special risks when handling the product and are accompanied by relevant signal words that express the extent of the risk. In addition, warning messages for possible property damage and useful information are also indicated by signal words.

WARNING!

Warning

This word with a warning triangle means there may be a considerable risk of fatal injury

- if the stated precautionary measures are not taken.
-

CAUTION!

Caution

This word with a warning triangle indicates that minor personal injury may occur

- if the stated precautionary measures are not taken.
-

ATTENTION!

Attention

This indicates that damage to property may occur

- if the stated precautionary measures are not taken.
-

Information

Information indicates important information about the product or serves to emphasize a section in the documentation that deserves special attention from the reader.

Embedded warning messages

Embedded warning messages are integrated directly into the instruction manual and are structured as follows:

SIGNAL WORD! Type of hazard, its cause and possible consequences of disregarding it! Measures for avoiding the hazard.

Signal words in embedded warning messages have the same meaning as in the normal warning messages described previously.

1.2 Limitation of liability

This documentation was created taking into account the applicable standards and regulations as well as the current state of technology.

No warranty or liability claims for damage shall result from failure to comply with the documentation or from use that deviates from the intended use of the product. This is especially true for damage caused by individual technical modifications to the product or the project configuration and operation of the product by unqualified personnel.

1.3 Product names and brands

Product names that are registered as brands are not specifically identified in this documentation. Existing property rights (patents, trademarks, protection of utility models) are to be observed.

1.4 Additional documentation

You can find supporting technical documents for this product when you enter the serial number of the product at <https://id.stober.com> or scan the QR code on the product's nameplate.

You will find more information about the product at <http://www.stober.de/en/downloads/>. Enter the ID of the documentation in the Search... field.

Documentation	ID
Instructions for configuration of the MH300 drive controller	442806
MH300 series user manual	DELTA_IA-MDS_MH300_UM_EN_20240110

The user manual for the MH300 drive controller can be found at the following address: <https://downloadcenter.deltaww.com/en-US/DownloadCenter?v=1&dataType=2&q=MH300>

1.5 Copyright notice

Copyright © STOBBER. All rights reserved.

2 Safety notes

Hazards may arise through the use of the product described in this documentation. Read and always observe the safety notes in this chapter. Doing so allows you to prevent hazards to people and property.

2.1 Intended use

The motors / geared motors described in this documentation are intended for installation and operation in commercial and industrial machines or systems.

The following are considered non-intended use:

- Any overloading or exceeding of the maximum permitted speeds of the motors / geared motors
- Use in ambient conditions that deviate from those described in this documentation
- Modifying or refitting the motors / geared motors
- Direct operation on a three-phase network
- Operation in potentially explosive atmospheres

Commissioning the machine in which the motors / geared motors are installed is prohibited until it has been determined that the machine corresponds to regional laws and guidelines. In the EU, the following guidelines in particular are to be observed in their respective scope:

- (Machinery) Directive 2006/42/EC
- (Low Voltage) Directive 2014/35/EU
- (EMC) Directive 2014/30/EU

2.2 Requirements for personnel

All mechanical tasks that arise during the assembly, commissioning, maintenance and removal of the product may be performed only by specialized personnel who hold a corresponding qualification in the field of metal technology.

All electrical tasks that arise during the assembly, commissioning, maintenance and removal of the product may be performed only by electrically skilled persons who hold a corresponding qualification in the field of electrical engineering.

Tasks that arise during transport, storage and disposal may be performed by personnel who have been instructed in the suitable method for doing so.

Furthermore, personnel who handle the product must carefully read, understand and observe the valid regulations, legal requirements and applicable basic rules as well as this documentation and the safety notes it contains.

2.3 Prevention of personal injury

2.3.1 Electrical hazards

The motor can be operated safely if handled correctly and while observing the safety notes. Despite this, the electrical voltage that powers or is generated by the motor can pose a danger to persons. Therefore, observe the following warning messages.

⚠ WARNING!**The motor is powered by high electrical voltage!**

Touching live parts is extremely dangerous and potentially fatal!

- The electrical connection of the motor may be carried out only by an electrician.
- Before performing the electrical connection, switch off the power supply of the machine with the main switch and secure it from being turned on again.
- Connect the motor only using a cable that has been supplied or approved by STOBBER.
- Do not open the motor housing cover.

⚠ WARNING!**Due to integrated permanent magnets, the rotating motor shaft generates high voltage that is present on the pin contacts of the plug connector.**

Touching live parts is extremely dangerous and potentially fatal!

- Only perform work on the motor when the motor shaft is at a standstill.
- Do not touch the cable ends or pin contacts of the plug connector.

2.3.2 Mechanical hazards

The motor converts electrical energy into kinetic energy during operation. Machine parts that are set in motion by this pose a possible danger to persons. Therefore, observe the following warning messages.

⚠ WARNING!**Dangerous movements of machine parts!**

Moving machine parts can cause serious injuries or even death!

- ✓ Before starting the drive:
 - Install all protective devices necessary for operation.
 - Make sure that no one is standing in the danger area or able to enter it unchecked.
 - Leave the danger area.

⚠ WARNING!**Unsecured feather keys or drive elements can be thrown due to the rotation of the input shaft!**

Flying metal parts can cause serious injuries!

- Mount the provided drive elements properly or remove them before a test run.
-

2.3.3 Thermal hazards

⚠ CAUTION!

The surface of the motor / geared motor can reach temperatures over 100 °C during operation!

Touching the hot surface of the motor / geared motor can cause severe skin burns!

- Do not touch the motor / geared motor during or immediately after operation.
- Allow the motor / geared motor to cool sufficiently before carrying out work on the motor / geared motor.
- Wear protective gloves when working on the motor / geared motor.

2.3.4 Hazards due to magnetic or electromagnetic fields

⚠ WARNING!

Strong magnetic and electromagnetic fields in the immediate vicinity of the motor!

Magnetic and electromagnetic fields can impair the function of sensitive electronic devices such as pacemakers and can cause serious health-related harm as a result!

- Take suitable protective and instructive measures so that persons with pacemakers do not enter the immediate vicinity of or work with the motor.



2.4 Prevention of property damage

ATTENTION! The surface of the motor can reach temperatures over 100 °C during operation! Take suitable measures so that temperature-sensitive components such as connection cables do not come into contact with the motor housing.

ATTENTION! Strong magnetic and electromagnetic fields in the immediate vicinity of the motor! Keep sensitive electronic devices and magnetic data carriers away from the motor.

2.5 Warning labels on the motor

Warning labels are attached to the motor housing. Keep the warning labels in good, legible condition.

Warning label	Meaning
	Warning of high electrical voltage. Do not connect or disconnect the plug connectors until after the motor is de-energized. Only perform work on the motor when the motor shaft is at a standstill.
	The surface of the motor can reach high temperatures during operation. Do not touch the motor during operation or immediately afterward.

3 Product description

In this chapter, you will find product details that are relevant for assembly, commissioning and servicing. Detailed technical data on your drive can be found in the order confirmation. You will find more product information and dimensional drawings in the corresponding catalog ([Additional documentation](#) ▶ 5). The respective separate technical documentation applies to attached motors.

3.1 Basic structure

The basic structure of the CLM motors is explained in this chapter using an example.

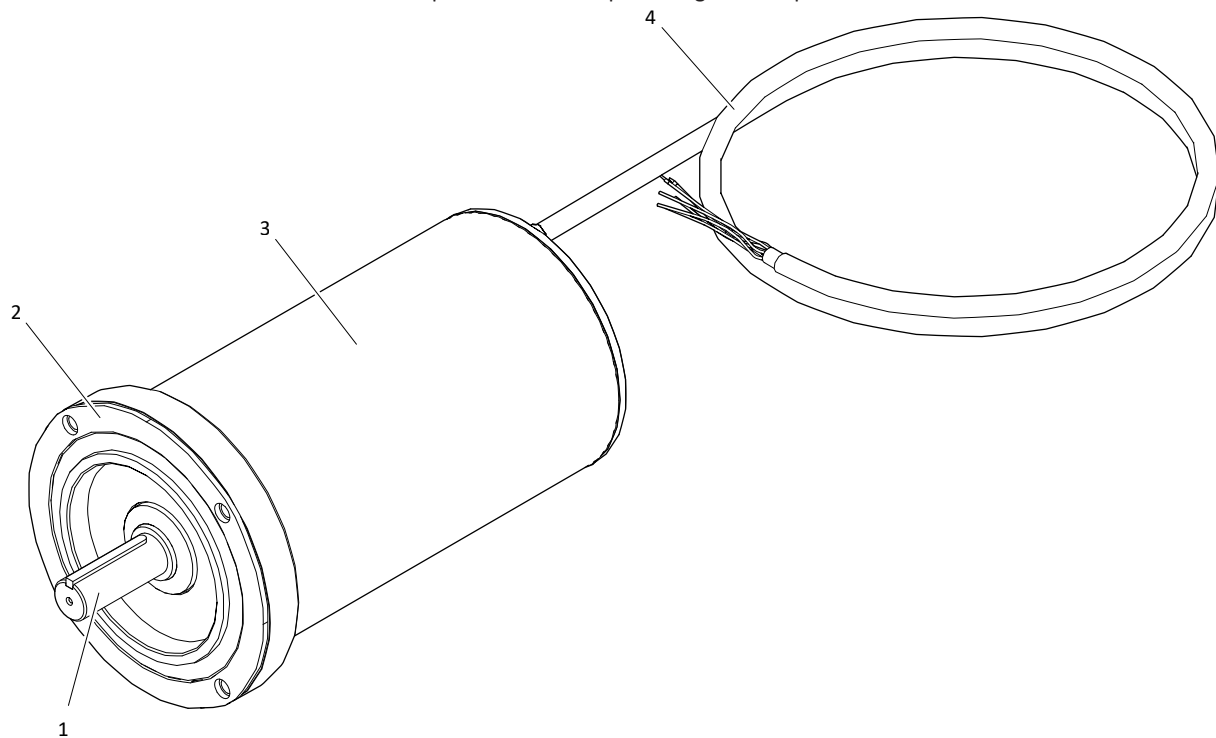

Fig. 1: Structure of a CLM503 motor

1	Output shaft	2	Output flange
3	Motor housing	4	Connection cable

3.2 Type designation

Example code

CLM	5	0	3	U	S	HF	O	201
-----	---	---	---	---	---	----	---	-----

Explanation

Code	Designation	Design
CLM	Type	cLEAN motor
5	Size	5 (example)
0	Generation	0
3	Length	3 (example)

Code	Designation	Design
U	Cooling	Convection cooling
S	Design	Standard
HF	Drive controller	MH300 (example)
O	Brake	Without brake
201	Voltage constant K_{EM}	201 V/1000 rpm (example)

3.3 Nameplate

An example nameplate of an CLM503 motor is explained in the figure below.

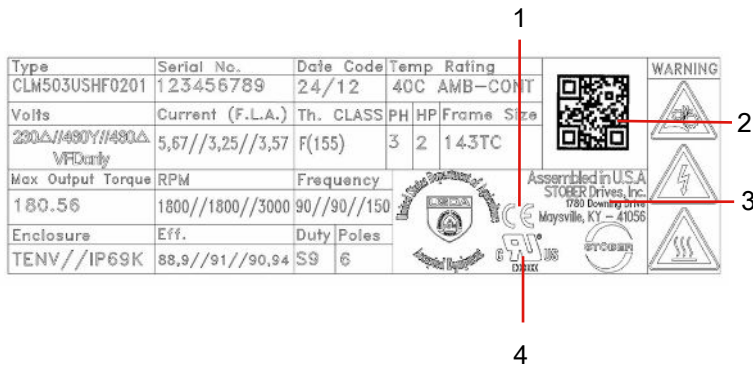

Field/Position	Value	Description
Type	CLM503USHF0201	Type designation
Serial No.	123456789	Serial number of the motor
Date code	24/12	Date of manufacture (year/week)
Temp rating	40C AMB-CONT	Maximum surrounding temperature
Volts	230Δ // 460Y // 460Δ VFD only	Supply voltage and circuit Operation only permitted on a drive controller
Current (F.L.A.)	5.67 // 3.25 // 3.57	Nominal current (depending on the circuit)
Th. CLASS	F(155)	Thermal class
PH	3	Number of phases
HP	2	Nominal power
Frame size	143TC	NEMA size
Max Output torque	180.56	Maximal torque
RPM	1800 // 1800 // 3000	Nominal speed (depending on the circuit)
Frequency	90 // 90 // 150	Nominal frequency (depending on the circuit)
Enclosure	TENV // IP69K	Protection class
Eff.	88.9 // 91 // 90.94	Efficiency (depending on the circuit)
Duty	S9	Nominal operating mode
Poles	6	Number of poles
1	CE	CE mark
2	QR code	Link to product information
3	STOBER	Name and address of the manufacturer
4	cURus	cURus test symbol

3.4 General features

Feature	Description
Design	Sensorless synchronous motor with interior permanent magnets
Design	IM B5, IM V1, IM V3 in accordance with EN 60034-7
Protection class	IP69K
Thermal class	155 (F) in accordance with EN 60034-1 (155 °C, heating $\Delta\vartheta = 100$ K)
Surface	SAE 304 stainless steel
Cooling	IC 410 convection cooling
Bearing	Rolling bearing with lifetime lubrication and non-contact sealing
Sealing	Radial shaft seal rings made of FKM (A side)
Shaft	Shaft with feather key, diameter quality k6
Radial runout	Normal tolerance class in accordance with IEC 60072-1
Concentricity	Normal tolerance class in accordance with IEC 60072-1
Axial runout	Normal tolerance class in accordance with IEC 60072-1
Vibration intensity	A in accordance with EN 60034-14
Noise level	Limit values in accordance with EN 60034-9

3.5 Electrical features

Feature	Description
DC link voltage	DC 540 V (max. 620 V) or DC 270 V (max. 310 V) to Delta MH300 drive controller
Winding	Three-phase
Circuit	Delta (AC 230 V or AC 460 V supply voltage) Star (AC 460 V supply voltage)
Protection class	I (protective grounding) in accordance with EN 61140
Number of pole pairs	3

3.5.1 Temperature sensor

A PTC thermistor is installed in STOBBER CLM motors as a standard temperature sensor for implementing thermal winding protection. The PTC thermistor is a triple thermistor in accordance with DIN 44082 that can be used for monitoring the temperature of each winding phase.

STOBBER CLM motors are available in versions with a Pt1000 temperature sensor. The Pt1000 is a temperature-dependent resistor that has a resistance curve with a linear relationship with temperature. As a result, the Pt1000 allows for measurements of the winding temperature. These measurements are limited to one phase of the motor winding, however. In order to adequately protect the motor from exceeding the maximum permitted winding temperature, use a i^2t model in the drive controller to monitor the winding temperature.

Information about connecting the temperature sensor can be found in chapter [Electrical connection](#) [▶ 17].

3.6 Ambient conditions

Standard ambient conditions for transport, storage and operation of the motor are described in this chapter.

Feature	Description
Surrounding temperature for transport/storage	-30 °C to +85 °C
Surrounding temperature for operation	-15 °C to +40 °C
Installation altitude	≤ 1000 m above sea level
Shock load	≤ 50 m/s ² (5 g), 6 ms in accordance with EN 60068-2-27

Notes

- STOBBER CLM motors are not suitable for potentially explosive atmospheres in accordance with (ATEX) Directive 2014/34/EU.
- Also take into consideration the shock load of the motor due to output units (such as gear units and pumps) which are coupled with the motor.

To prevent damage, protect the motor from the following influences:

- Environments with harmful oils, acids, gases, vapors, dust or radiation
- Shaking, impacts, vibrations and high acceleration
- Sparks or heat

4 Transport and storage

STOBER products are packaged carefully and delivered ready for installation. The type of packaging depends on the product size and the transport method.

Observe the following information during transport and storage:

- Inspect the delivery for any transport damage immediately upon receiving it and report any transport damage immediately. Do not put damaged products into operation.
- Check your delivery for completeness using the delivery note and report any missing parts to the supplier.
- Transport and store the product in the original packaging in order to protect it from damage. Remove the original packaging and transport safety devices shortly before assembly.

Ambient conditions

The ambient conditions for transport and storage can be found in the chapter [Ambient conditions](#) [▶ 12].

4.1 Transport

Lifting and transporting the motor or geared motor may require lifting gear (e.g. a crane), depending on the weight. The weight of your motor or geared motor is specified in the accompanying delivery documents.

WARNING!

Suspended loads!

Loads that become loose and fall during the lifting process can cause serious injuries or even death!

- Observe the following instructions.
- Cordon off the danger zone and ensure that no one stands under the suspended loads.
- Wear safety shoes.

WARNING!

A damaged power cable or damaged cable gland can result in electric shock.

Contact with live parts is extremely dangerous and potentially fatal!

- Do not pull or lift the motor by the cable.
- Make sure the cable is not kinked or mechanically damaged.

Lift and transport the motor as follows:

- Use lifting gear with a sufficient lifting capacity for the weight of the motor and attached loads.
- On motors without eyebolts, run hoist slings directly around the motor housing and secure the hoist slings from slipping.
- Fasten loads attached to the motor such as gear units or output units as well and make sure that there is no diagonal pull.

In order to prevent falling or damage to the motor during transport, do not lift or fasten the motor on the output shaft or cable.

4.2 Storage

Store the motor in its original packaging in closed, dry spaces.

5 Installation

In this chapter, you can find information on the safe and correct assembly of the motor.

Inspect the motor and cable before assembly for damage due to transport or storage. If the motor or cable is damaged, do not install the motor and contact the STOBBER Service department. Check whether the requirements for ambient conditions at the assembly location are satisfied.

You will need the following tools for assembly:

- If necessary due to the overall weight, lifting gear with appropriate fastening elements and sufficient lifting capacity
- Standard tools
- Torque wrench
- Mounting device for power transmission elements

5.1 Assembly tolerances

In this chapter, you can find tolerances that must be observed during the assembly of the motor.

Tolerances for shafts in accordance with DIN 748-1

Diameter [mm]	Tolerance
≤ 50	ISO k6
> 50	ISO m6

Tolerances for centering diameter on the motor flange in accordance with EN 50347

Centering diameter [mm]	Flange size [mm]	Tolerance
≤ 230	65 – 300	ISO j6
> 230	350 – 500	ISO h6

5.2 Mounting the motor on a KSS gear unit

This chapter describes how to attach a CLM motor to a STOBBER KSS gear unit with an MSR motor adapter to a **curved tooth coupling**.

Procedure

1. In the following table, read off the XL dimension that corresponds to your motor adapter type.
2. Pull the motor-side coupling hub (4) onto the motor shaft (2) such that the XL dimension is complied with. If the coupling hub is difficult to fit on the motor shaft, do not use force and instead heat the coupling hub to about 80 °C before fitting.
3. Secure the coupling hub (4) with the set screw (5) and tighten it to a tightening torque of 2 Nm.
4. If possible, position the gear unit such that the motor can be mounted in a horizontal position.
5. Connect the coupling sleeve (6) to the gear unit-side coupling hub (9).
6. Turn the motor in an axial position to the gear unit so that the nameplates are on the same side, if possible, and can also be read after installation in the machine.

7. Carefully place the motor on the motor adapter such that the motor-side coupling hub (4) is inserted into the coupling sleeve (6) centered and the curved teeth of the coupling hub easily mesh with the internal teeth of the coupling sleeve.
8. The contact surfaces of the motor flange and motor adapter flange must fit together without a gap. If this is not the case, do not use force and instead check the dimensions of the motor.
9. Mount the motor with supplied stainless steel hex head screws (10) on the motor adapter. Use the supplied plug seals (8).
10. Tighten the hex head screws with a torque wrench to a tightening torque of 22 Nm.

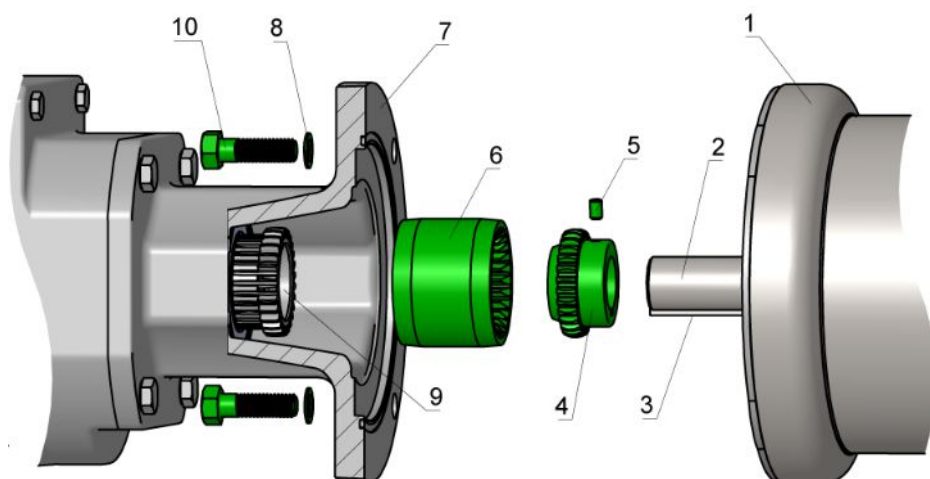
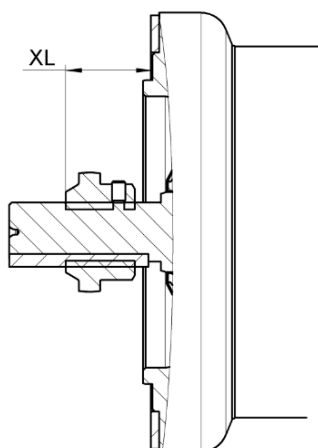

1	Motor	2	Motor shaft
3	Feather key	4	Coupling hub (motor side)
5	Set screw	6	Coupling sleeve
7	Motor adapter flange	8	Plug seal
9	Coupling hub (gear unit side)	10	Hex head screw

Motor adapters	NEMA size	XL (+0.04 / -0.00) [inch]	XL (+1.0 / -0.0) [mm]
MS1R/050	56C	0.94	24
MS2R/050	56C	1.02	26
MS2R/140	143TC	1.14	29
MS3R/050	56C	0.94	24
MS3R/140	143TC	1.14	29
MS4R/050	56C	0.94	24
MS4R/140	143TC	1.14	29

Tab. 1: XL dimension for installing the coupling hub

6 Electrical connection

Before carrying out the electrical connection of the motor, check whether the following prerequisites are fulfilled:

- The mechanical assembly of the motor is completed.
- The plug connectors of the supplied cable have no internal contamination or moisture.

WARNING!

The motor is powered by high electrical voltage!

Touching live parts is extremely dangerous and potentially fatal!

- The electrical connection of the motor may be carried out only by an electrician.
- Before performing the electrical connection, switch off the power supply of the machine with the main switch and secure it from being turned on again.
- Connect the motor only using a cable that has been supplied or approved by STOBBER.
- Do not open the motor housing cover.

ATTENTION! Directly connecting the motor to a three-phase network will cause damage to the motor! Connect the motor as described in this documentation.



6.1 Terminal assignment

The terminal assignment of the CLM motor is described in this chapter. As standard, the motor is delivered with a connected cable. The cable is either open or equipped with a plug connector with screw cap.

Flying lead

Connection diagram	Designation	Color	Connection
	U	black	U/T1
	V	black	V/T2
	W	black	W/T3
	1	green-yellow	Grounding conductor
	2	brown/blue	1TP1 (Temperature sensor +)
	3	white	1TP2 (Temperature sensor -)

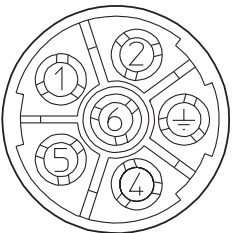
con.23 plug connector

Connection diagram	Pin	Connection	
	1	U/T1	
	2	V/T2	
	4	1TP1 (Temperature sensor +)	
	5	1TP2 (Temperature sensor -)	
	6	W/T3	
			Grounding conductor

6.2 Connecting the extension cable

If the power cable has a plug connector on the end, an extension cable from STOBBER can be connected to it.

On the drive controller side, the extension cable has an open end with the same terminal assignment as the power cable (see chapter [Terminal assignment](#) [[▶ 17](#)]).

ATTENTION! Unsuitable extension cables or plug connectors can damage the motor due to voltage peaks and cause thermal damage to plug connectors! Furthermore, they may fail to meet legal requirements for electromagnetic compatibility and may void any warranty claims! Use only cables that have been supplied by STOBBER.

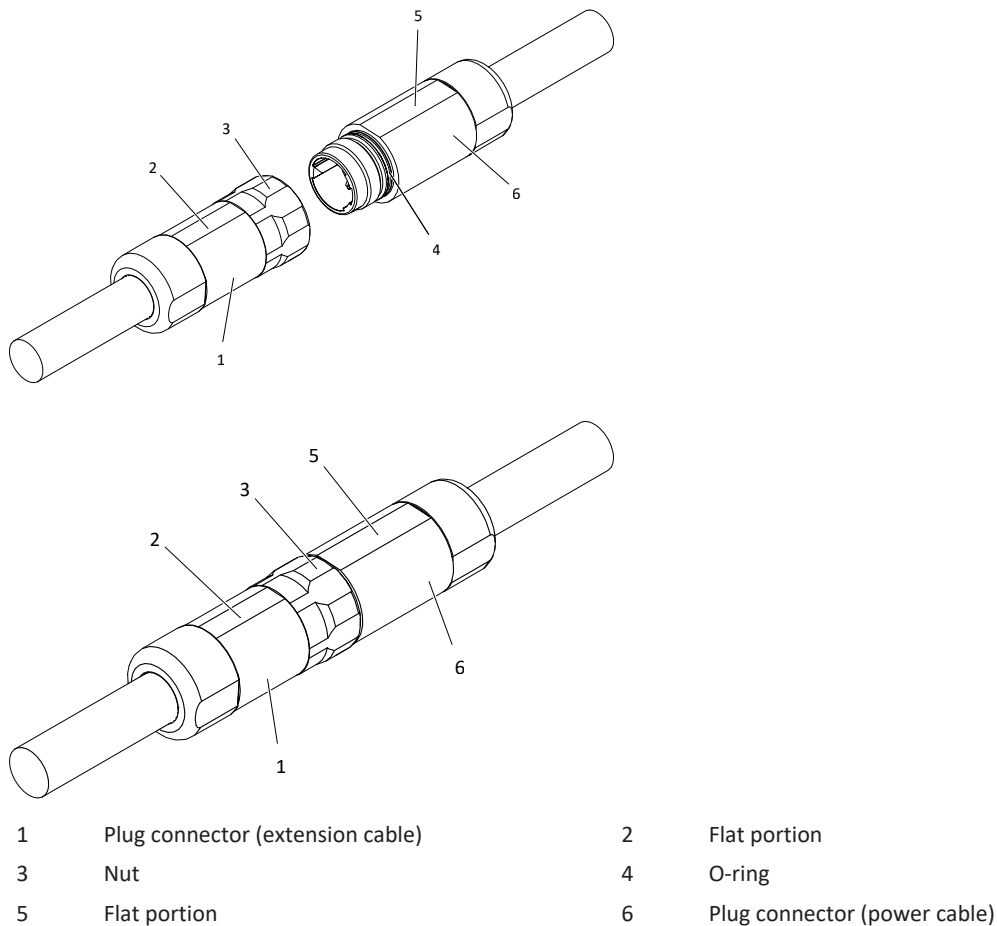

How to connect the extension cable with the power cable:

1. Make sure that the machine is de-energized and the motor shaft is at a standstill.
2. Align the plug connectors so that the flat portion (5) on the plug connector of the power cable (6) and flat portion (2) on the plug connector of the extension cable (1) are opposite each other.
3. Connect the two plug connectors.
4. Turn the nut (3) clockwise until the O-ring (4) is covered by the nut.

Cable routing

Route the cable to the machine so that it does not touch the motor housing during operation, as this gets hotter than 80 °C and can damage the insulation.

6.3 Connecting the motor to the drive controller

CLM motors can only be operated on Delta MH300 drive controllers. The power cable is ready-made so that it can be connected to the connections of the drive controller without additional effort.

During proper operation of the motor on the drive controller, leakage currents greater than 10 mA can occur. Connect the ground conductor for the motor (via the drive controller) to the grounding conductor system of the machine in order to protect persons from electric shock in case of contact with the motor housing.

The motor can be connected to the drive controller either directly or via a motor disconnecting switch.

6.3.1 Connection without motor disconnecting switch

Connect the motor to the drive controller in accordance with the following connection plan. Make sure that the ground conductor and both cable shields are connected to the ground terminals of the drive controller as illustrated.

ATTENTION! Failure to connect and monitor the temperature sensor may lead to damage to the motor and may void any warranty claims! Always connect the temperature sensor and activate the thermal winding protection in the drive controller.

You can find details on connection to the drive controller in the documents specified in chapter [Additional documentation](#) [► 5].

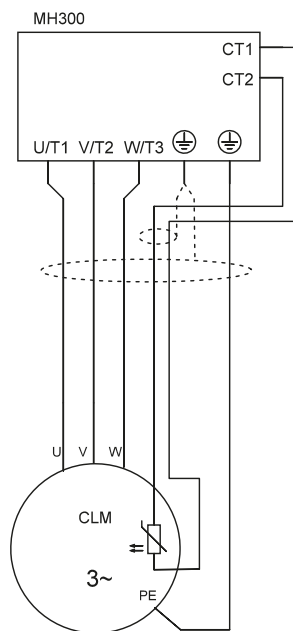

Fig. 2: Connection without motor disconnecting switch

CT1/CT2	Encoder connections of the drive controller	MH300	Drive controller
CLM	cLEAN motor		

6.3.2 Connection with motor disconnecting switch

WARNING! The motor disconnecting switch must have a lagging auxiliary contact that is used to de-energize the power cables of the drive controller before disconnecting the motor lines. Otherwise, an electric arc can be generated in the motor disconnecting switch and cause personal injury and property damage!

The cable from the motor disconnecting switch to the drive controller must be supplied by the customer.

CAUTION! Unsuitable cables can damage the motor due to voltage peaks and cause thermal damage to plug connectors! Furthermore, they may fail to meet legal requirements for electromagnetic compatibility and may void any warranty claims! Contact the service department of STOBBER for specifications for the cable from the motor disconnecting switch to the drive controller.

Connect the motor to the motor disconnecting switch and drive controller in accordance with the following connection plan. Make sure that the ground conductors and cable shields are connected to the ground terminals as specified.

ATTENTION! If the motor temperature in the drive controller is not monitored via the i2t model, this may lead to damage to the motor and may void any warranty claims! Monitor the motor temperature to protect the thermal winding protection of the motor.

You can find details on connection to the drive controller in the documents specified in chapter [Additional documentation](#) [▶ 5].

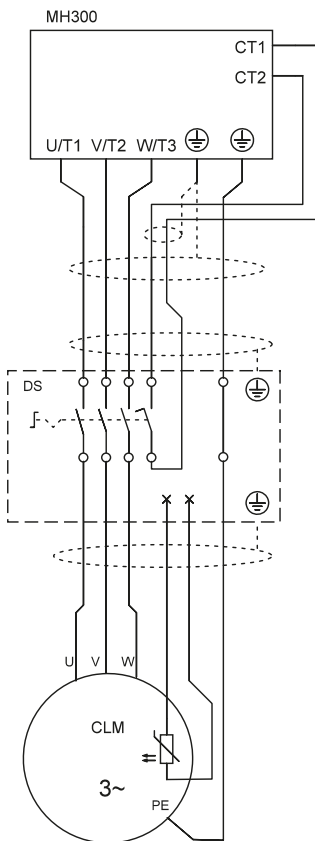

Fig. 3: Connection via a motor disconnecting switch

CT1/CT2	Encoder connections of the drive controller	DS	Motor disconnecting switch with lagging auxiliary contacts
MH300	Drive controller	CLM	cLEAN motor

7 Commissioning

7.1 Before commissioning

WARNING! Moving machine parts can cause serious injuries or even death! Before performing work, switch off the machine with the main switch and secure the switch from being turned on again.

Before commissioning the motor, make sure that the following prerequisites are met:

- The motor is undamaged.
- The mechanical assembly and electrical connection of the motor has been completed.
- The drive controller is ready for operation.
- The drive is not blocked.
- The feather key of the motor shaft has been secured from sliding off.
- All protective devices have been assembled properly.
- Heat-sensitive components (e.g. cables) have been routed so that they do not touch the motor surface.
- The motor surface is not covered with any heat-insulating materials.
- No persons are in the danger area.

7.2 Parameterizing the motor

All the required motor parameters are stored in the MH300 drive controllers supplied by STOBBER. This ensures that just a few parameters have to be adapted. Make sure that thermal winding protection is activated. You can find more information in the documents that are specified in chapter Additional documentation.

7.3 During commissioning

WARNING! Moving machine parts can cause serious injuries or even death! Make sure that no one is standing in the danger area or able to enter it unchecked.

WARNING! If the motor is in operation while plug connectors are being disconnected, electric arcs can cause severe injury or even death. Do not connect or disconnect the plug connectors until after the motor is de-energized.

WARNING! Flying metal parts can cause serious injuries! Assemble the provided power transmission elements properly or remove the feather key before a test run.

CAUTION! The surface of the motor can reach temperatures over 100 °C during operation! Allow the motor to cool sufficiently before working on it. Wear gloves.

During commissioning, check the following:

- Is the direction of rotation of the motor or drive correct?
- When the motor is running, does any overloading, unwanted speed fluctuations or unusual noises occur?

In case of faults, observe the chapter [Remedying faults](#) [▶ 23].

8 Servicing

8.1 Maintenance

The maintenance tasks described in this chapter are necessary in order to maintain the functionality of the motor. The rolling bearings of the motor are maintenance-free.

WARNING! A damaged drive or motor can result in electric shock or injury! Do not climb on the drive or motor during maintenance. Instead, use suitable climbing aids if needed.

8.1.1 Cleaning

If the motor surface is dirty, sufficient heat dissipation through the surrounding air is no longer possible. As a result, the lifespan of the motor bearings may be reduced since the motor bearing lubricant breaks down in the event of impermissibly high temperatures. Furthermore, the thermal winding protection may force a shut-down of the motor before the motor has reached its nominal values.

Determine the cleaning interval according to the expected operating conditions, but it should be every 12 months at the latest. Clean the motor according to the following instructions.

WARNING! Moving machine parts can cause serious injuries or even death! Before performing work, switch off the machine with the main switch and secure the switch from being turned on again.

CAUTION! The surface of the motor can reach temperatures over 100 °C during operation! Allow the motor to cool sufficiently before working on it. Wear gloves.

ATTENTION! Improper cleaning can cause damage to the motor! Note the following limitations for high-pressure cleaning:

- Water temperature < 80 °C
- Pressure < 100 bar
- Distance from the emitter to the motor > 10 cm
- Solvent compatible with FKM seals

8.1.2 Visual inspection

Perform regular visual inspections for damage to the motor and connection cable according to the following checklist. Determine the inspection interval according to the expected operating conditions of the motor, but every 12 months at the latest. Clean the motor before the visual inspection.

WARNING! Moving machine parts can cause serious injuries or even death! Before performing work, switch off the machine with the main switch and secure the switch from being turned on again.

CAUTION! The surface of the motor can reach temperatures over 100 °C during operation! Allow the motor to cool sufficiently before working on it. Wear gloves.

Checklist

- Is the connection cable damaged? If it is, do not perform any temporary repairs. Instead, replace the connection cable.
- If a cable extension is used, is the nut of the plug connector is correctly tightened?

If the motor or connection cable is damaged, decommission the machine and replace the damaged component.

8.1.3 Review during operation

Check the motor for deviations regularly during operation. Determine the inspection interval according to the expected operating conditions of the motor. Before commissioning, make sure that no persons are put at risk and no property damage occurs as a result. Pay attention in particular to the following deviations from normal operation:

- Increased motor vibrations
- Unusual motor noises
- Burning odors in the vicinity of the motor
- Diagnostic and error messages from the drive controller

In case of deviations from normal operation or in case of faults, proceed according to the instructions in chapter [Remedying faults](#) [▶ 23].

8.2 Remedying faults

In the following table, you can find information for remedying motor faults.

WARNING! Moving machine parts can cause serious injuries or even death! Before performing work, switch off the machine with the main switch and secure the switch from being turned on again.

Faults	Possible causes	Measures for remedying
Motor does not start	Enable from drive controller not present	Activate enable in the drive controller
	Error in the drive controller	Remedy error according to the drive controller documentation
	Power supply missing	Check connection and power supply
	Cable connected incorrectly	Connect cable correctly
	Drive blocked mechanically	Remedy the block
	Holding brake (if present) not released	Check connection and actuation of the holding brake
	Motor defective	Contact the STOBBER Service department
Increased operating temperature or activation of thermal winding protection	Motor housing heavily contaminated	Clean motor housing
	Intake or discharge of cooling air blocked by foreign object	Ensure unimpeded intake and discharge of cooling air
	Motor overloaded by the application	Reduce load or check layout
	Holding brake (if present) does not lift entirely	Contact the STOBBER Service department
Increased vibrations during operation	Motor or geared motor assembled tightly	Check the assembly of the motor or geared motor
	Fastening screws loose	Tighten the fastening screws correctly
Running noises	Revolving parts dragging	Determine and remedy cause
	Bearing damage	Contact the STOBBER Service department
Sporadic failure of the motor	Cable break	Replace connection cable

8.3 Servicing

Have the necessary servicing work carried out on the motor by the STOBBER Service department or by STOBBER service partners. Be aware that improper servicing may cause material damage and may void the manufacturer's warranty.

Only use replacement parts delivered by STOBBER. Specify the type designation and serial number of the motor when ordering replacement parts. These can be found on the nameplate of the motor.

The contact data from the STOBBER Service department can be found on the last page of this documentation.

9 Removal and disposal

9.1 Removal

Remove the motor as follows:

WARNING! Moving machine parts can cause serious injuries or even death! Before performing work, switch off the machine with the main switch and secure the switch from being turned on again.

WARNING! Falling gravity-loaded axes or vertical axes can cause serious injuries or even death! Move gravity-loaded axes or vertical axes to their lowest position and lock or brace them mechanically before entering the danger area.

CAUTION! The surface of the motor can reach temperatures over 100 °C during operation! Allow the motor to cool sufficiently before working on it. Wear gloves.

1. Disconnect the connection cable from the motor (see chapter [Electrical connection](#) [▶ 17]).
2. Unscrew the screws used to mount the motor to the machine or gear unit.
3. Pull the output flange of the motor off of the machine or gear unit.
4. Transport the motor according to chapter [Transport and storage](#) [▶ 13].

9.2 Disposal

Dispose of the component parts of the motor according to applicable regulations and when doing so, observe the following information:

- The motor predominantly consists of stainless steel, copper, brass, plastics and permanent magnets (rare earth metal).
- The motor does not contain any hazardous materials.
- Permanent magnets must be properly demagnetized before disposal.



443443_en.00

04/2024

STÖBER Antriebstechnik GmbH + Co. KG
Kieselbronner Str. 12
75177 Pforzheim
Germany
Tel. +49 7231 582-0
mail@stoeber.de
www.stober.com

24 h Service Hotline
+49 7231 582-3000

www.stober.com