

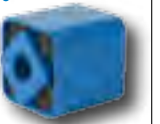











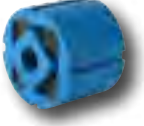

Selection chart for rubber suspension standard elements with Rubmix 10

Inner square Housing	A Light metal profile, as from size 60 in steel	C Light metal profile	S Steel tube for plug-in connection	Accessories for housing Steel parts
DR Steel tube	DR-A 15 to 50  Page 1.6	DR-C 15 to 50  Page 1.6	DR-S 11 to 50  Page 1.7	Bracket BR 11 to 50  Page 1.7
DK Light metal profile	DK-A 15 to 50  Page 1.8	DK-C on request 	DK-S 11 to 50  Page 1.8	Bracket BK 11 to 50  Page 1.9
DW Light metal profile	DW-A 15 to 38  Page 1.10	DW-C 15 to 38  Page 1.10	DW-S 15 to 38  Page 1.10	Accessories for inner square A Steel parts WS 11 to 50  Page 1.13
DW Nodular cast iron	DW-A 45 and 50  Page 1.11	DW-C 45 and 50 on request 	DW-S 45 and 50  Page 1.11	
DW Steel welded construction	DW-A 60 to 100  Page 1.11			
DO Light metal profile Size 50 in nodular cast iron	DO-A 15 to 50  Page 1.12	DO-C on request 	DO-S on request 	
Housing Specification inner squares	<p>Ideal for alternating motions over neutral element position.</p> <p>For sizes DR 15–45: Fixation by means of 2 to 4 persistent threaded bars (sizes DR 27–45 also available with threaded holes).</p>	<p>Friction locking of the core by means of one central bolt, can be positioned in full 360° angle-range. For ideal friction locking, please remove paint cover on face side. For alternating element motion of max. ±10°.</p>	<p>For plug-in connection with square profile*. Plug-in length min. 2 x width across flat "C". Connection is not recommendable by alternating motions – play between the plugged squares.</p>	<p>* The square should be made out of bright steel, tolerance h9–h11. Possibly, the edges have to be overwinded (edge-radius in element profile max. 1.5 mm).</p>

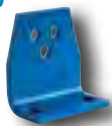
Specification

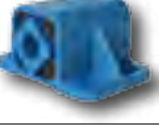
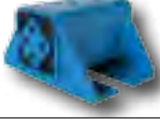
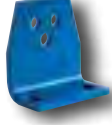
DR-A 15 x 25

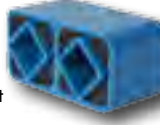
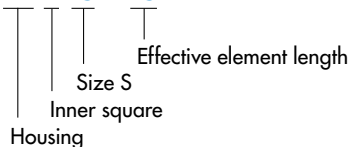

General

- Light metal profiles: extruded profiles, seawater resistant (DIN 1725).
- Blue protection paint: water-soluble paint, coating thickness 40–80 µm.
- Fixation screws: minimum strength class of 8.8
- Welding on elements: do not weld on rubber suspensions – welding heat will affect or destroy the rubber inserts – ask for customized elements
- Most of the elements can be supplied in stainless steel version – also zinc-plated versions or special paintings are available.

Further customized elements: see examples on page 1.14 to 1.19.

Rubber Suspension Units

Serial Connection

Doubled oscillating angle
($\pm 60^\circ$) at constant torque of a single unit.

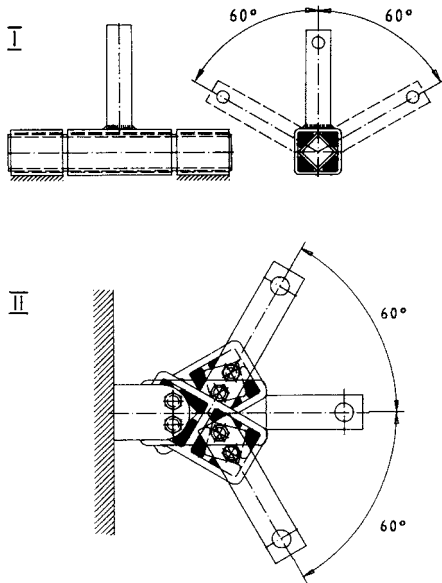

Parallel Connection

Doubled torque momentum
at constant oscillating angle ($\pm 30^\circ$).

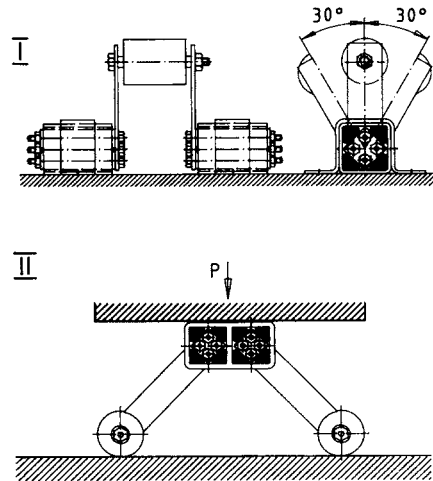

Accessory Bracket WS

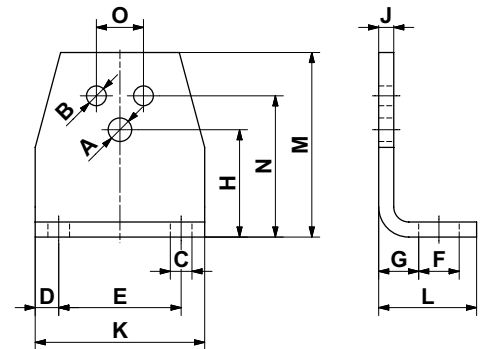

Bracket WS		Fit for tensioner devices			Fit for DR-A, DK-A, DW-A												Weight [kg]	
Art. No.	Type	SE size	ϕA	H	Element size	ϕB	N	O	C	D	E	F	G	J	K	L		M
06 590 001	WS 11-15	11	6.5	27	15	5.5	35	10	7	7.5	30	13	11.5	4	45	30	46	0.08
06 590 002	WS 15-18	15	8.5	34	18	6.5	44	12	7	7.5	40	13	13.5	5	55	32	58	0.15
06 590 003	WS 18-27	18	10.5	43	27	8.5	55	20	9.5	10	50	15.5	16.5	6	70	38	74	0.28
06 590 004	WS 27-38	27	12.5	57	38	10.5	75	25	11.5	12.5	65	21.5	21	8	90	52	98	0.70
06 590 005	WS 38-45	38	16.5	66	45	12.5	85	35	14	15	80	24	21	8	110	55	116	0.90
06 590 006	WS 45-50	45	20.5	80	50	12.5	110	40	18	20	100	30	26	10	140	66	140	1.80

Administrative and Technical Information

1. Guidance, services and offers

Please contact your local ROSTA representative listed in our representatives list on the back of the catalogue if you have any questions or concerns.

We require a full list of technical specifications including any available sketches and data sheets for the preparation of an appropriate offer. This information makes it possible for us to determine whether a standard or custom element is the most cost-effective solution for you. For complex applications, our representative or the home office will send you a questionnaire about the exact specifications for what you need.

Terms and conditions for payments and deliveries are included with our offer or available on our website at www.rosta.com → Company → General Terms.

2. Orders and deliveries

Please include the offer number on your order along with the exact quantity, product name and number. Please send your order to your local ROSTA representative.

3. Availability

Most of the standard products listed in our catalogue are available from stock through your local representative or directly from ROSTA AG.

Custom pieces for a specific customer requirement are produced and delivered as specified in your order confirmation. The delivery time for special custom pieces can be reduced by signing a call order agreement (make-and-hold-order) with ROSTA AG. Please contact us if you would like to discuss this.

4. Technical information

Please observe the capacity limits for our elements as specified in the catalogue. If you are in doubt, please contact us or your ROSTA representative.

Please follow the assembly instructions detailed in the catalogue. Make sure that your assembly workers are instructed correctly. If you have any questions, please contact us or your ROSTA representative.

Assembling elements: To attach our elements or mounts, please always use the largest dimensioned standard machine bolts possible with a minimum strength class of 8.8 that fit into the drilled holes in the elements or attachment clamps. Use an ISO 898 table or your screw supplier's guidelines for the maximum tightening torque.

If in doubt, control your bolt attachments using the VDI Guidelines 2230.

Use DIN 125A stamped washers to attach housings with unworked drilled holes in the casting (for example AB 50) or oblong holes (for example MB supports).

5. Proviso

This catalogue and our other technical information are intended solely for your orientation and information; they may not be construed as absolutely binding in any way. We ask that you adapt the assembly and use of our products in a way suited to the prevailing conditions and situation.

The reproduction of this document in full or in part may only be done with our expressed written permission.

The leading manufacturer of torsional rubber springs



SUBSIDIARIES

Australia www.rostaaustralia.com.au **Canada** www.rosta.ca **China** www.rostachina.com
Germany www.rosta.de **Italy** www.rostaitalia.com **USA** www.rosta.com

DISTRIBUTORS

Argentina heuchert@ciudad.com.ar **Austria** www.haberkorn.com **Belgium/Luxemburg** www.atbautomation.eu
Brazil www.atibrasil.com.br **Chile** www.riosan.cl **Czechia** www.rupet.eu **Denmark** www.jens-s.dk **Finland** www.sks.fi
France www.rosta.com **Great Britain** www.kobo.co.uk **Greece** www.alexandris.com **Iceland** www.falkinn.is
India www.technotalent.in **Japan** www.mikipulley.co.jp **Lithuania/Latvia** www.techvitas.lt
Malaysia www.masterjaya.com.my **Netherlands** www.atbautomation.eu **New Zealand** www.saecowilson.co.nz
Norway www.jens-s.no **Peru** www.grupo-isc.com **Philippines** www.severosyling.com **Poland** www.archimedes.pl
Portugal www.april.pt **Russia** www.fam-drive.ru **Singapore** henry@smcomponent.com **Slovenia** www.m-trade.si
South Africa www.orangevmc.co.za **South Korea** www.sewonworld.co.kr **Spain** www.tracsa.com
Sweden www.kontima.se **Thailand** www.virtus.co.th **Turkey** www.entatek.com



Changes regarding data reserved.
Any reprint, also in extracts, requires
our explicit and confirmed approval.



ROSTA AG

Hauptstrasse 58
CH-5502 Hunzenschwil

Phone +41-62-889 04 00
Fax +41-62-889 04 99
E-Mail info@rosta.ch
Internet www.rosta.com

ROSTA



T2016-914