



Leadshine

Stock Code: 002979



LT2000T SERIES HMI

High Speed High Capacity IoT

Company Profile

- **Founded in 1997**
- **Public Listed Company in China (002979.SZ)**

Dedication in Motion Control

- Stepper/Servo systems, Motion Controllers, PLC
- Control systems, I/O Modules, Encoders
- **A leading supplier of motion control products and solutions in the world**
- **Customer Oriented, Technology Oriented, Forever Improving, Sharing of Success**



Headquarters in Shenzhen



Industrial Park in Shanghai



Production base in Shenzhen

R&D

Led by Dr. Li, a PhD majored in robotics & servo controls from MIT, Leadshine has one of the strongest R&D teams in the motion control industry.

The team consists of more than 100 R&D engineers and all of them are highly educated with most of them carry PhD & Master degrees in controls, electrical & electronics engineering, mechanical engineering, mechatronics, computer engineering, and computer science.

Their strong background and experience allow Leadshine capable of designing superior quality products based the latest technology in the most efficient way.

Product Quality

Leadshine operates manufacturing facilities which are superiorly equipped, professionally staffed, and ISO-9001 certified.

That allows Leadshine to provide highly reliable quality motion control products OEM clients in the shortest time.

Leadshine's products have proven records of being successfully adopted in thousands of applications such as CNC routers, mills, plasmas, lathes, laser cutters/engravers/markers, inkjet printers, plotters, electronics equipments, medical equipments, semiconductor assembly & inspection machines, electronics machines, packaging equipments, textile machines, robotics, pick-and-place devices, etc. In most cases, Leadshine's standard "off-the-shelf" products are able to satisfy the motion control needs for most applications.

For many OEM applications with special requirements, Leadshine also offers customized products with optimized performance.

Support and Service

Leadshine believes the key to be a successful motion product supplier is the commitment to fully understanding our customer's applications and working closely with our OEM clients.

In many cases, Leadshine engineers can participate in the whole process of client product development, including initial application evaluation, product selection, design help & suggestion.

Our expertise and experience allow us to help OEM clients to produce competitive high quality machines in their industries.

Your Reliable Motion Control Partner

LT2000 SERIES HMI

Excellent appearance and performance, fully meeting your various needs in different occasions

The leadshine HMI LT2000 series has a exquisite appearance,clear display,and sensitive to touch. It is equipped with LT Studio configuration software,which makes simpler to use when combined with products such as the leadshine motion control PLC, AC servo,and stepper to form a total solution.

Product Features

Clear, Bright, And Full View

High definition and brightness LCD display, with a maximum view angle of 170 °

4.3"	800x480	170°	250cd / m ²
7"	1024x600	170°	350cd / m ²
10.1"	1024x600	170°	400cd / m ²
15.6"	1920x1080	170°	250cd / m ²



Support Ethernet Expansion Module

Remote configuration can be achieved by connecting the third Ethernet expansion module

- PLC remote download
- Data configuration
- Historical data query
- Alarm configuration



Multiple Port Types

Support RS232/RS485/RS422/Ethernet communication and download using USB/Mini USB/Type-C

RS232/RS485/RS422	PLC communication third-party communication
USB	USB flash drive download
mini USB/Type-C	Program download
Ethernet	PLC/Visual Communication



Easy to Use Configuration Software

Programming and configuration software LT Studio for convenient user experience

- Supporting most PLCs and drives
- Supporting label variables
- Structured software architecture
- Clearly categorized menu bar
- Easy to access toolbar
- Comes with commonly used window screens

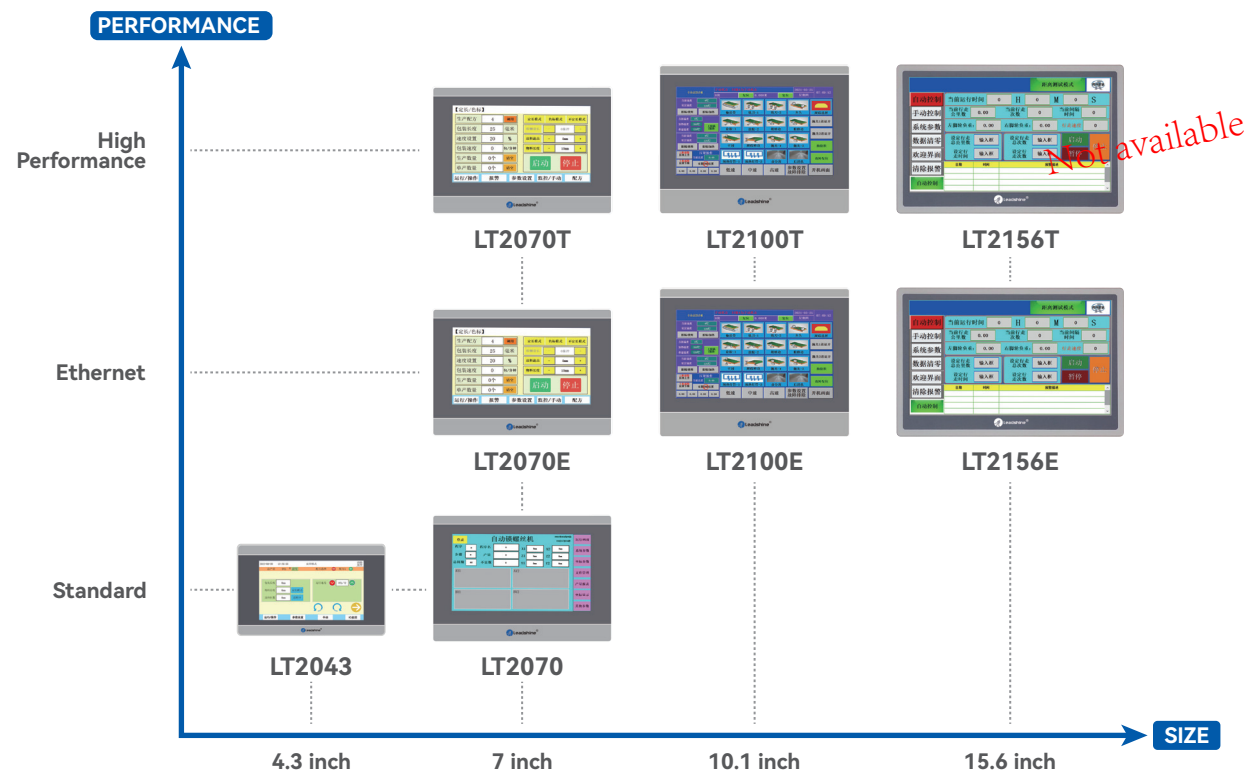
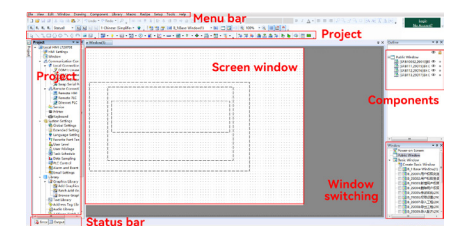

Naming Rules



Typical Ethernet Application

One Master and One Slave Serial Port Communication Application

By connecting RS232/RS485 port of the LT2000 series HMI to the port of the leadshine small/medium/large-sized PLC, master-slave serial communication can be achieved.

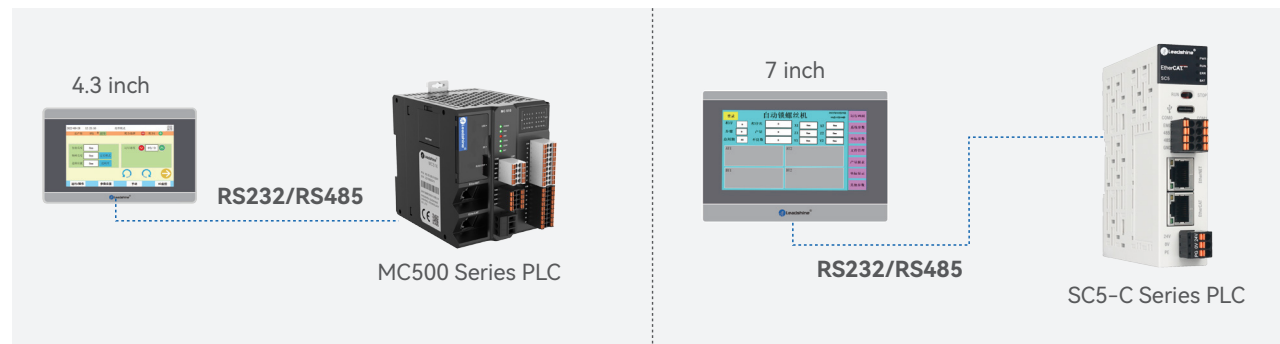

Integrated Drive and Control System Application

By connecting the RS485 serial port of the LT2000 series HMI to the servo/stepper drive port in PR mode, direct control through macro commands is possible without a controller.

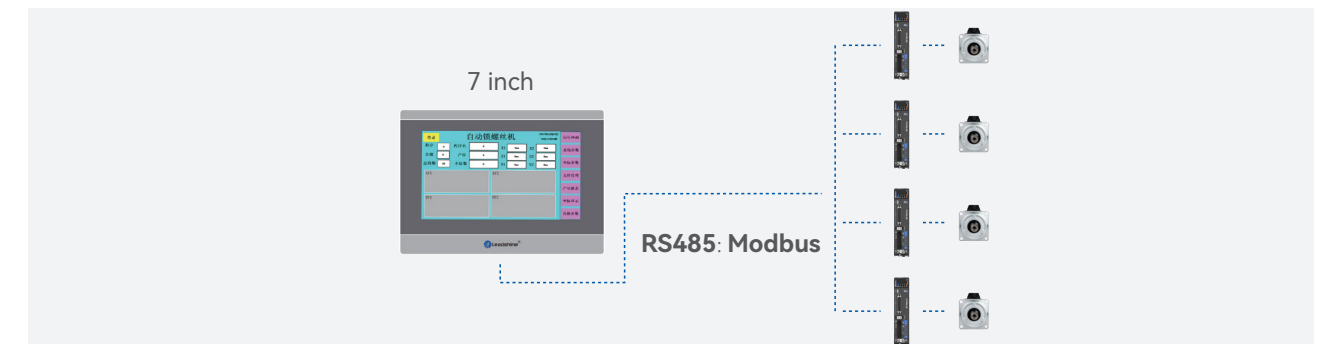

One Master and One Slave Ethernet Communication Application

By connecting ethernet interface of the LT2000 series HMI to the ethernet interface of the leadshine large/medium/small-sized PLC, master-slave serial communication can be achieved.

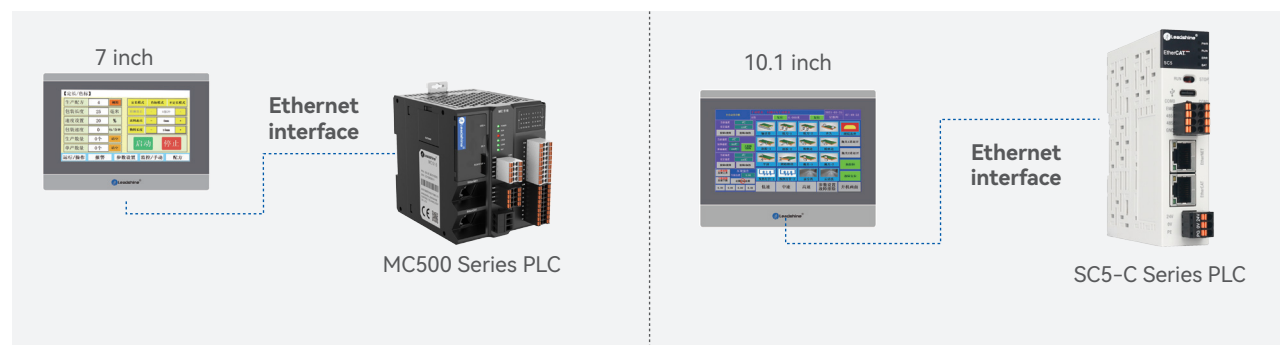

One Master and Multiple Slave Application

Simply establish multiple slave connections in the configuration software, and an LT2000 series HMI can communicate and connect with multiple leadshine small/medium/large-sized PLCs through serial or Ethernet port.

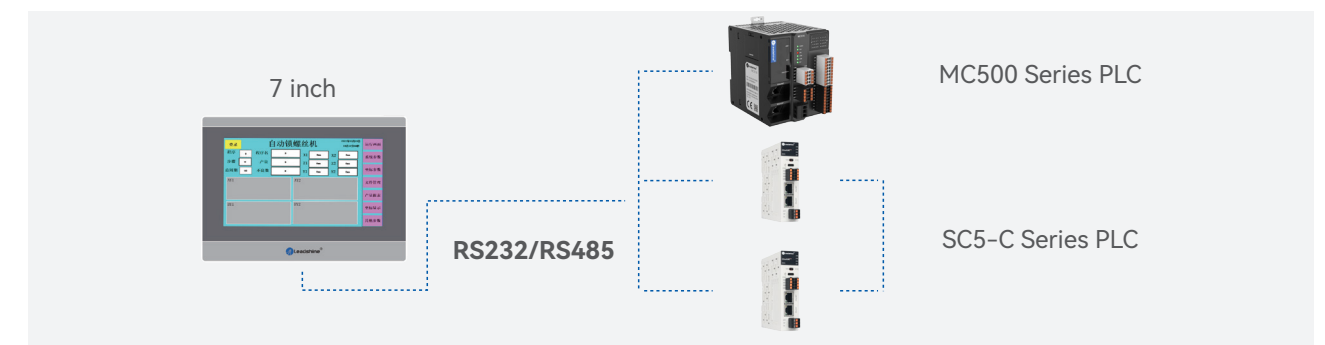

One Master and One Slave Single-chip device Communication Application

By connecting the RS232 communication port of the LT2000 series HMI to Single-chip device with RS232 communication port, and using macro commands, master-slave serial communication can be achieved, such as port communication between HMI and micro printer.

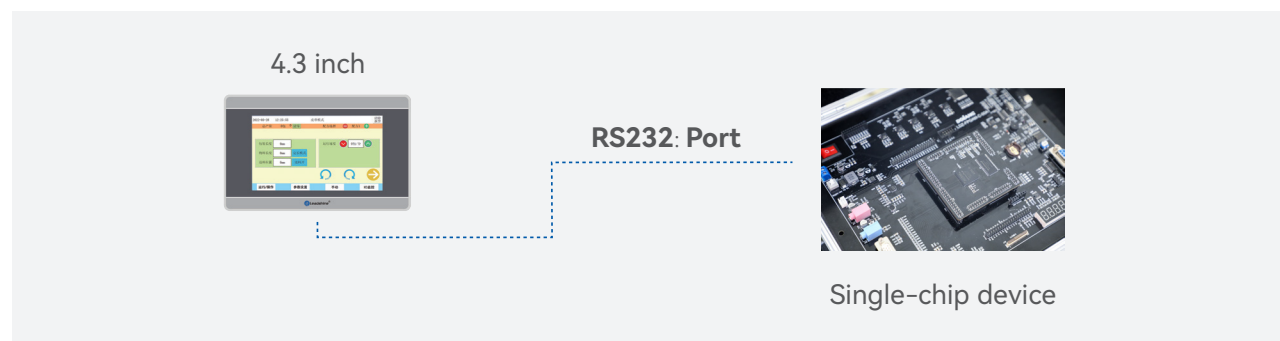

Multiple Master and One Slave Application

By using a handover machine and setting the IP address to different addresses in different network segments, multiple LT2000 series touch screens can be connected to multiple master/slave communication networks of Rexay small/medium/large-sized PLCs, in order to achieve monitoring of PLCs at different locations on large machines.

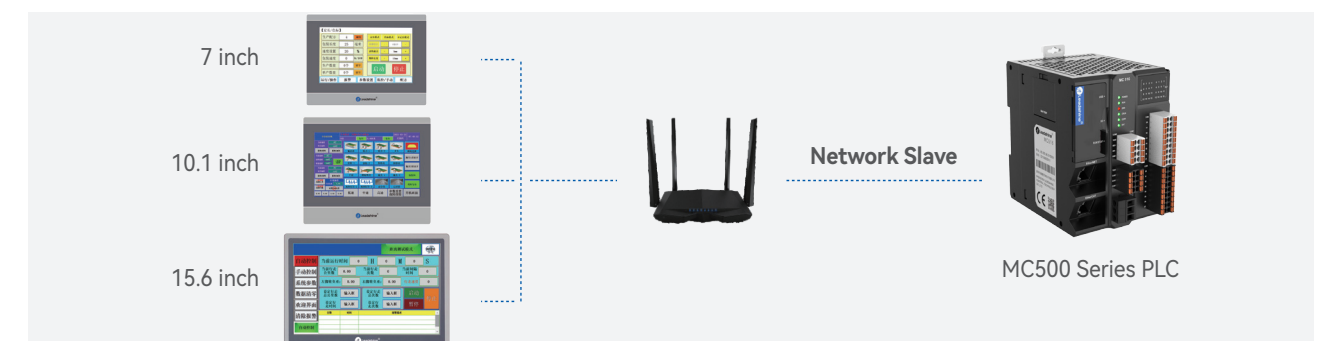

LT2043

- 4.3-Inch Standard HMI



Product Specifications

Hardware Specifications	Display Screen	4.3" 16:9 TFT LCD
	Resolution	800×480
	Display Color	16-Bit
	Brightness	250 cd/m ² (maximum 275cd/m ²)
	Backlight	LED
	LCD Lifetime	50000 Hours
	Touch Screen	4-Wire Industrial Resistive Touch Screen
	CPU	720MHz ARM
	Flash	64MB RAM+128MB Flash
	RTC	Configured RTC
	Ethernet	/
	SD Card	/
	USB Port	1 * Type-C OTG Port
	Program Download Method	USB Slave USB Flash Drive
Serial Communication Port	COM1: RS232/RS485/RS422	
Electrical Specifications	LCD Viewing Angle (T/B/L/R)	80°/80°/80°/80°
	Rated Power	< 2.5W
	Rated Voltage	DC24V, Range DC 9V~28V
	Power Protection	Lightning Surge Protection
Environmental Requirements	Power-Off Time	< 5ms
	CE & RoHS	EN61000-6-2:2005, EN61000-6-4:2007 ; Lightning Surge±1KV, Group-Pulse±2KV; Contact Discharge 4KV, Air Discharge 8KV ; ROHS
	Operating Temperature	0~50°C
	Storage Temperature	-20~60°C
	UV Protection	Do Not Expose The HMI To Environments With Strong UV (Such As Outdoors With Direct Sunlight) For A Long Time
	Operating Humidity	10~90%RH (Without Condensation)
	Vibration Resistance	10~25Hz (X、Y、Z Direction 2G/30 Minutes)
Mechanical Characteristics	Cooling Method	Air Cooling
	IP	IP65 For Front Panel And IP20 For Rear Cover
	Mechanical Structure	ABS
	Cut-Out Mounting Dimensions (Mm)	132mm×80mm
	Overall Dimensions	138mm×86mm×32mm
Weight	300g	

Outline Dimensions

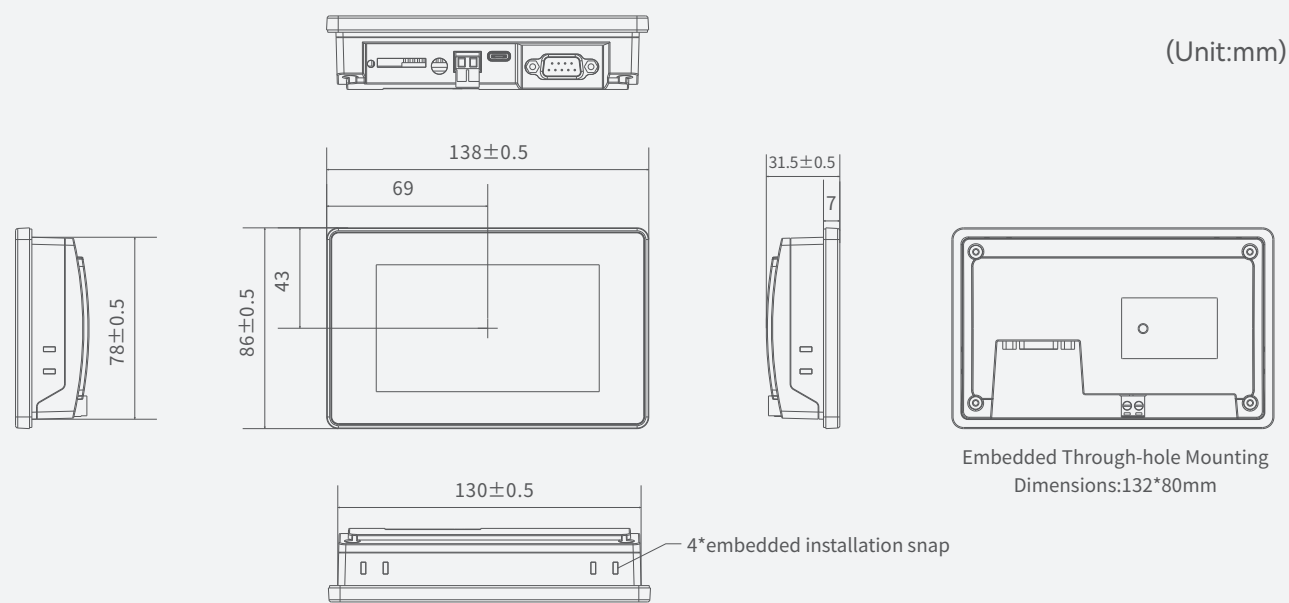

Port Information

No.	Name	Description
①	DB9 Male	Supports RS232, RS422, and RS485 for connection to PLC or other devices
②	Type-C Port	Salve port: download program and debugging. Master port: connect to USB flash drive, code scanning machine etc.
③	Power Port	DC 24V

LT2070

- 7 Inch Standard HMI

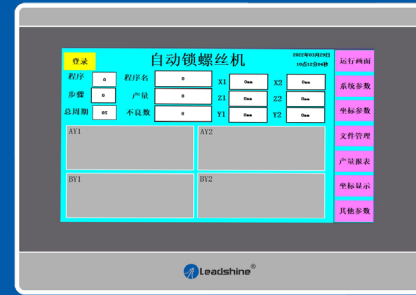

Product Specifications

Hardware Specifications	Display Screen	7" 16:9 TFT LCD
	Resolution	800×480
	Display Color	16 bit
	Brightness	250 cd/m ² (maximum 275cd/m ²)
	Backlight	LED
	LCD Lifetime	50000 Hours
	Touch Screen	4-Wire Industrial Resistive Touch Screen
	CPU	"720MHz
	Flash	64MB RAM+128MB Flash
	RTC	configured RTC
	Ethernet	/
	SD CARD	/
	USB PORT	1*USB Slave 2.0 port 1*USB Host 2.0port
Program Download Method	USB Slave/ USB Flash drive	
Serial Communication Port	COM1: RS232/RS485/RS422 COM3: RS232	
Electrical Specifications	Rated Power	< 10W
	Rated Voltage	DC24V, Range DC 9V~28V
	Power Protection	Lightning surge protection
	Power-Off Time	< 5ms
	CE & RoHS	EN61000-6-2:2005, EN61000-6-4:2007
	Environmental Requirements	Operating Temperature
Storage Temperature		-20~60°C
UV Protection		Do not expose the HMI to environments with strong UV (such as outdoors with direct sunlight) for a long time
Operating Humidity		10~90%RH(without condensation)
Vibration Resistance		10~25Hz (X、Y、Z Direction 2G/30 minutes)
Cooling Method		Air Cooling
Mechanical Characteristics	IP	IP65 for front panel and IP20 for rear cover
	Mechanical Structure	ABS
	Cut-Out Mounting	192mm×138mm
	Overall Dimensions	204mm×145mm×33.8mm
	Weight	575g

Outline Dimensions

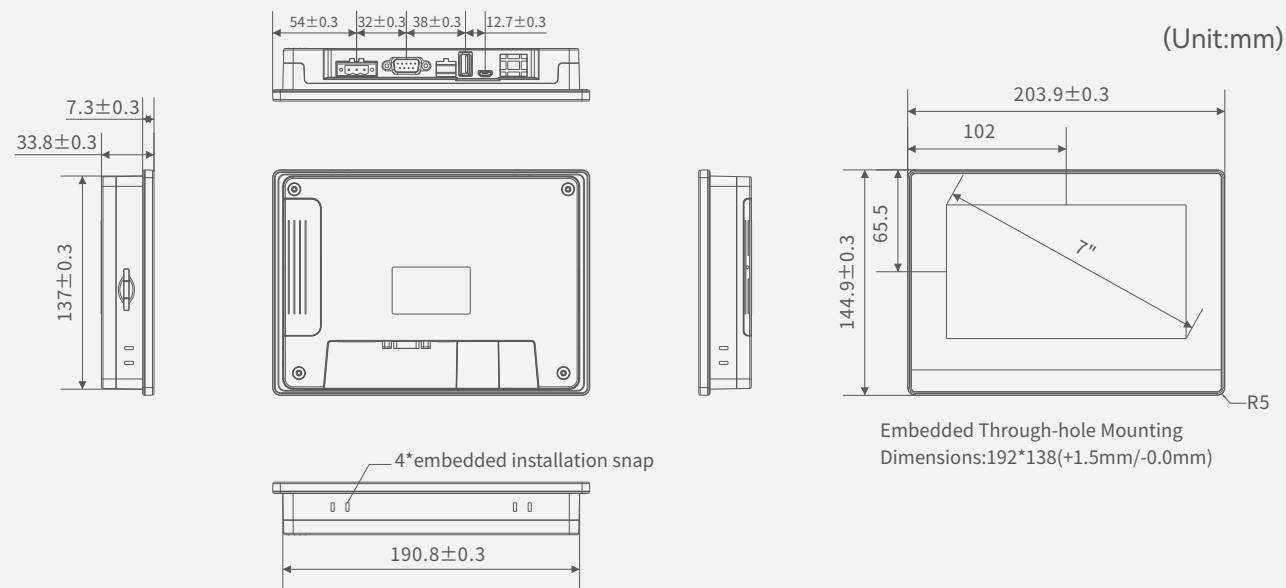

Port Information

No.	Name	Description
①	Power Port	DC 24V
②	DB9 Male	Supports RS232, RS422, and RS485 for connection to PLC or other devices
③	USB Port	Connect to USB flash drive, code scanning machine etc.
④	MiniUSB Port	Used to download programs and debugging

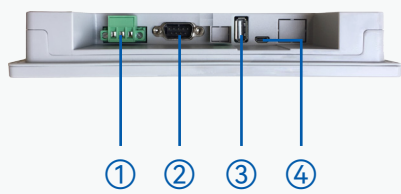

LT2070T

- 7-Inch HMI with high-performance

LT2070E

- 7-Inch HMI with Ethernet interface



Outline Dimensions

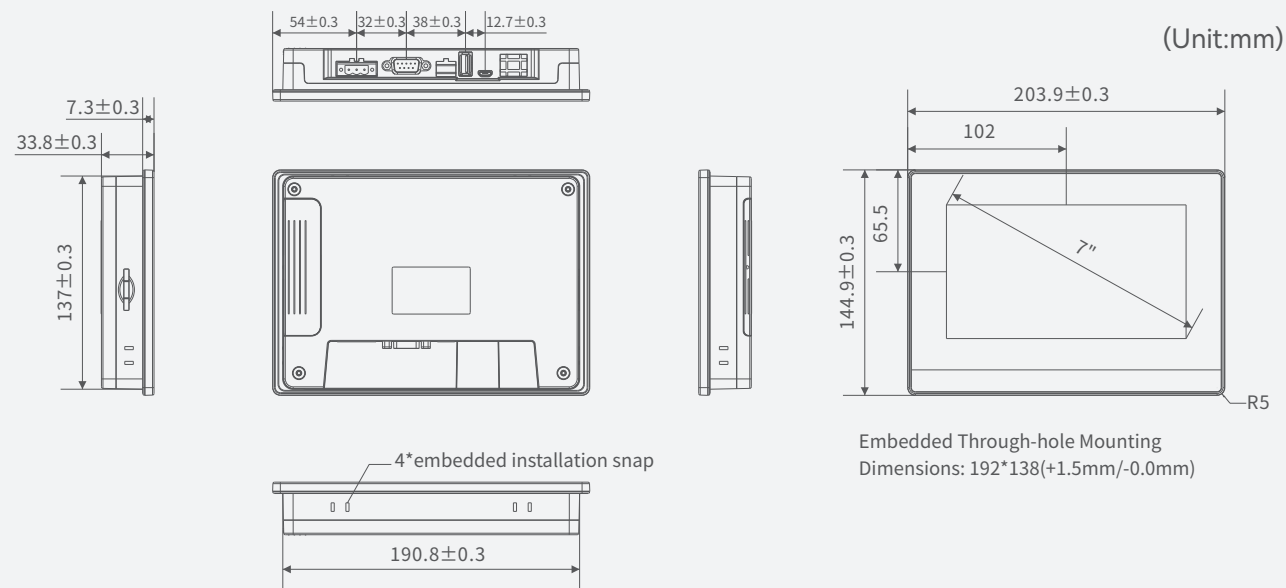

Port Information

No.	Name	Description
①	Power Port	DC 24V
②	DB9 Male	Supports RS232, RS485 for connection to PLC or other devices
③	RS485 Port	Connection to PLC or other devices
④	USB Host	Connect to USB flash drive, code scanning machine etc.
⑤	USB Slave	Used to download programs and debugging
⑥	Ethernet Port	Used for downloading programs or connecting PLC with Ethernet port

Product Specifications

Hardware Specifications	Display Screen	7" 16:9 TFT LCD
	Resolution	1024×600
	Display Color	24Bit
	Brightness	350 cd/m ²
	Backlight	LED
	LCD Lifetime	50000 Hours
	Touch Screen	4-Wire Industrial Resistive Touch Screen
	CPU	LT2070E:600MHz ARM Cortex-A8
		LT2070T:4-core 1.2GHz ARM Cortex-A7
	Flash	LT2070E:128M Flash + 128M DDR3
		LT2070T:4GB EMMC+256M DDR3
	RTC	Configured RTC
	Ethernet	1 *10M/100M Self-Adaption
SD CARD	Configured SD Card	
USB PORT	1*USB Slave 2.0 port; 1*USB Host 2.0 port	
Program Download Method	USB Slave/USB Flash drive/Ethernet	
Serial Communication Port	COM1:RS232/RS485/RS422 COM2:RS485 COM3:RS232	
LCD Viewing Angle (T/B/L/R)	85°/85°/85°/85°	
Electrical Specifications	Rated Power	< 10W
	Rated Voltage	DC24V, Range DC 9V~28V
	Power Protection	Lightning surge protection
	Power-Off Time	< 5ms
CE & RoHS	EN61000-6-2:2005,EN61000-6-4:2007	
	Lightning Surge±1KV,Group-Pulse±2KV	
	Contact Discharge 4KV,Air Discharge 8KV	
Environmental Requirements	Operating Temperature	0~50°C
	Storage Temperature	-20~60°C
	UV Protection	Do Not Expose The HMI To Environments With Strong UV (Such As Outdoors With Direct Sunlight) For A Long Time
	Operating Humidity	10~90%RH(Without Condensation)
	Vibration Resistance	10~25Hz(X, Y, Z Direction 2G/30 minutes)
	Cooling Method	Air Cooling
Mechanical Characteristics	IP	IP65 For Front Panel And IP20 For Rear Cover
	Mechanical Structure	ABS
	Cut-Out Mounting	192mm×138mm
	Overall Dimensions	204mm×145mm×33.8mm
	Weight	560g

LT2100E

- 10.1-Inch HMI with Ethernet interface



Product Specifications

Outline Dimensions

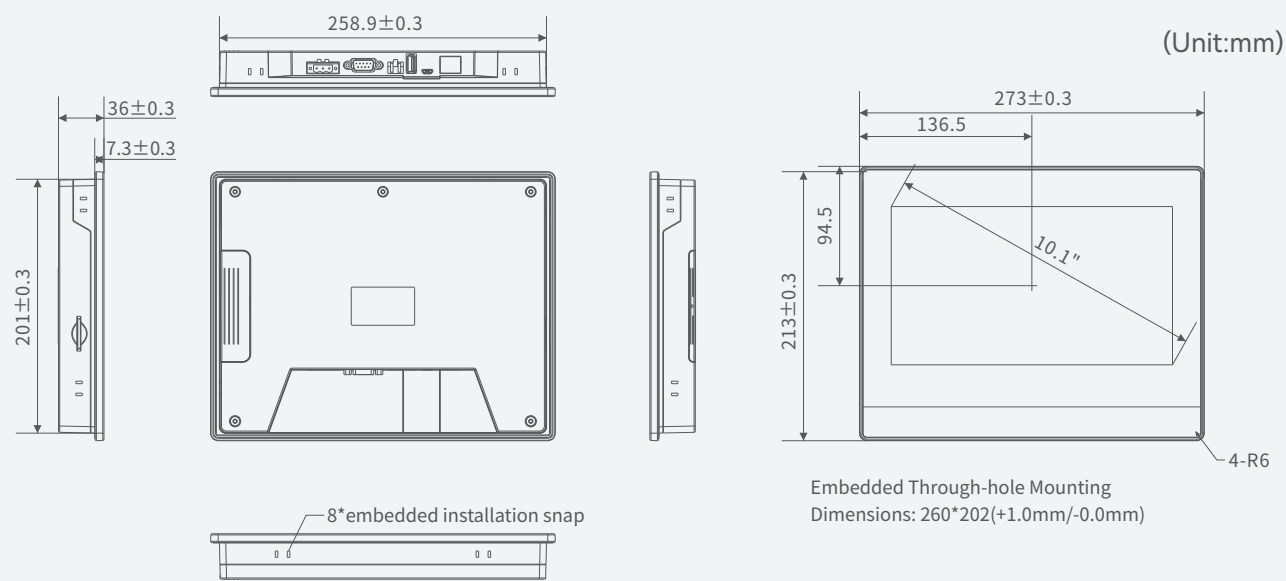

Port Information

No.	Name	Description
①	Power Port	DC 24V
②	DB9 Male	Supports RS232, RS485 for connection to PLC or other devices
③	RS485 Port	Connection to PLC or other devices
④	USB Host	Connect to USB flash drive, code scanning machine etc.
⑤	USB Slave	Used to download programs and debugging
⑥	Ethernet Port	Used for downloading programs or connecting PLC with Ethernet port

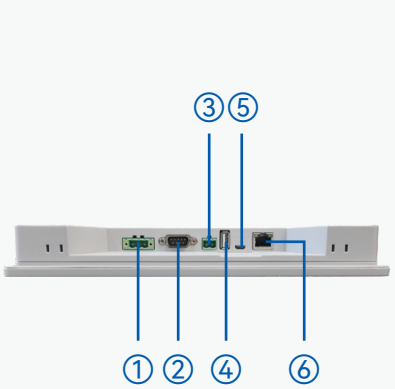

Hardware Specifications	Display Screen	10.1" 16:9 TFT LCD
	Resolution	1024×600
	Display Color	24-Bit
	Brightness	400 Cd/M ²
	Backlight	LED
	LCD Lifetime	50000 Hours
	Touch Screen	4-Wire Industrial Resistive Touch Screen
	CPU	600mhz ARM Cortex-A8
	Flash	128M Flash + 128M DDR3
	RTC	Configured RTC
	Ethernet	1 *10M/100M Self-Adaption
	SD CARD	Configured SD Card
	USB PORT	1*USB Slave 2.0 port; 1*USB Host 2.0 port
	Program Download Method	USB Slave/USB Flash drive/Ethernet
Serial Communication Port	COM1:RS232/RS485/RS422 COM2:RS485 COM3:RS232	
LCD Viewing Angle (T/B/L/R)	85°/85°/85°/85°	
Serial Communication Port	COM1:RS232/RS485/RS422 COM2:RS485 COM3:RS232	
LCD Viewing Angle (T/B/L/R)	85°/85°/85°/85°	
Electrical Specifications	Rated Power	< 10W
	Rated Voltage	DC24V, Range DC 9V~28V
	Power Protection	Lightning surge protection
	Power-Off Time	< 5ms
	CE & RoHS	EN61000-6-2:2005,EN61000-6-4:2007 Lightning Surge±1KV,Group-Pulse±2KV Contact Discharge 4KV,Air Discharge 8KV ROHS
Environmental Requirements	Operating Temperature	0~50°C
	Storage Temperature	-20~60°C
	UV Protection	Do Not Expose The HMI To Environments With Strong UV (Such As Outdoors With Direct Sunlight) For A Long Time
	Operating Humidity	10~90%RH(Without Condensation)
	Vibration Resistance	10~25Hz(X, Y, Z Direction 2G/30 minutes)
Cooling Method	Air Cooling	
Mechanical Characteristics	IP	IP65 For Front Panel And IP20 For Rear Cover
	Mechanical Structure	ABS
	Cut-Out Mounting	260mm×202mm
	Overall Dimensions	273mm×213mm×36mm
	Weight	920g

LT2100T

- 10.1-Inch HMI with high-performance

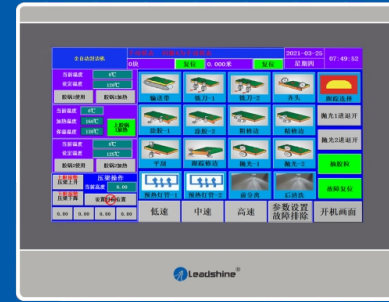

Outline Dimensions

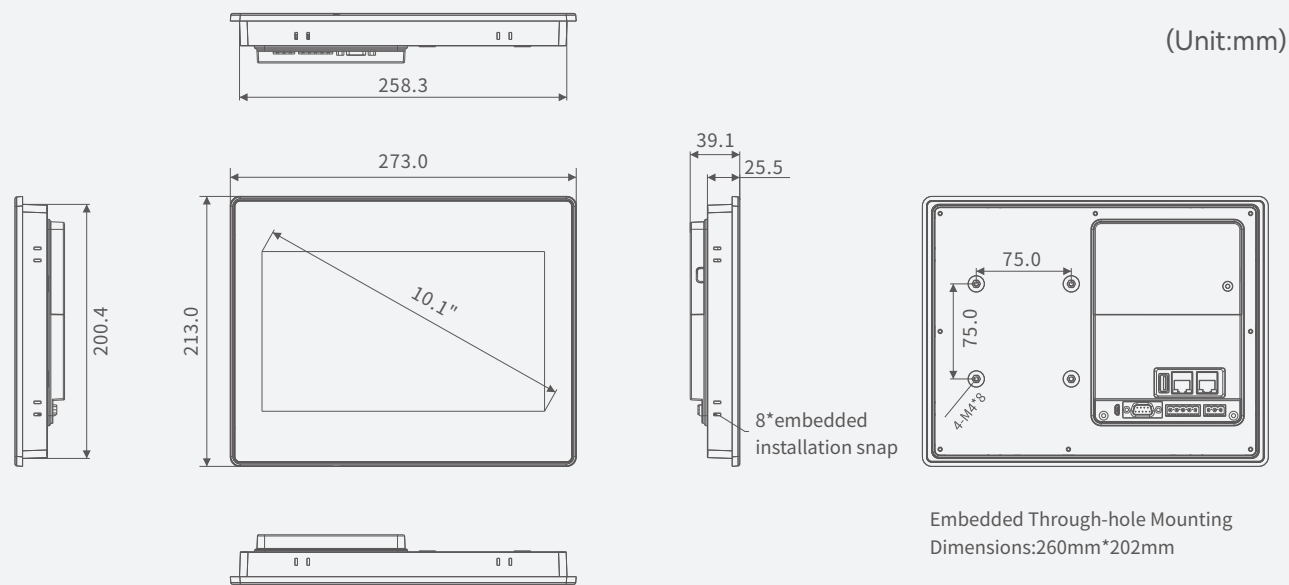

Port Information

No.	Name	Description
①	Power Port	DC 24V
②	RS485 Port	Connection to PLC or other devices
③	DB9 Male	Supports RS232, RS485 for connection to PLC or other devices
④	USB Host	Connect to USB flash drive, code scanning machine etc.
⑤	USB Slave	Used to download programs and debugging
⑥	Ethernet Port	Used for downloading programs or connecting PLC with Ethernet port

Product Specifications

Hardware Specifications	Display Screen	10.1" 16:9 TFT LCD
	Resolution	1024×600
	Display Color	24Bit
	Brightness	400 cd/m ²
	Backlight	LED
	Lifetime	50000 Hours
	Touch Screen	4-Wire Industrial Resistive Touch Screen
	CPU	4-core 1.2G Cortex-A53
	Flash	1GB DDR + 8GB Flash
	RTC	Configured RTC
	Ethernet	1 *10M/100M Self-Adaption
	SD CARD	Micro SD (TF) Card
	USB PORT	1*USB Slave 2.0 port; 1*USB Host 2.0 port
	Program Download Method	USB Slave/USB Flash drive/Ethernet
	Serial Communication Port	COM1:RS232/RS485/RS422 ;COM2:RS485/RS422; COM3:RS232
LCD Viewing Angle (T/B/L/R)	85°/85°/85°/85°	
Serial Communication Port	COM1:RS232/RS485/RS422 COM2:RS485 COM3:RS232	
LCD Viewing Angle (T/B/L/R)	85°/85°/85°/85°	
Electrical Specifications	Rated Power	< 10W
	Rated Voltage	DC24V, Range DC 9V~28V
	Power Protection	Lightning surge protection
	Power-Off Time	< 5ms
	CE & RoHS	EN61000-6-2:2005,EN61000-6-4:2007 Lightning Surge±1KV,Group-Pulse±2KV Contact Discharge 4KV,Air Discharge 8KV ROHS
Environmental Requirements	Operating Temperature	-10~60°C
	Storage Temperature	-20~70°C
	UV Protection	Do Not Expose The HMI To Environments With Strong UV (Such As Outdoors With Direct Sunlight) For A Long Time
	Operating Humidity	10~90%RH(Without Condensation)
	Vibration Resistance	10~25Hz(X, Y, Z Direction 2G/30 minutes)
Mechanical Characteristics	Cooling Method	Air Cooling
	Installation	Embedded installation/VESA installation
	IP	IP65 For Front Panel And IP20 For Rear Cover
	Mechanical Structure	Aluminum Alloy Shell
	Cut-Out Mounting	260mm×202mm
Overall Dimensions	274mm×214mm×39mm	
Weight	1450g	

LT2156T

Not available

- 15.6-Inch HMI with high-performance

LT2156E

- 15.6-Inch HMI with Ethernet interface

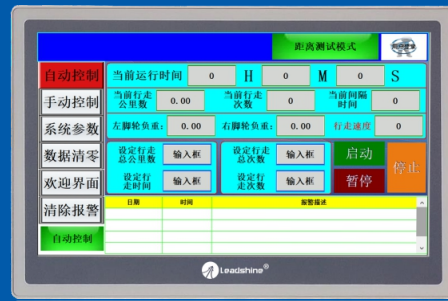

Product Specifications

Hardware Specifications	Display Screen	15.6" 16:9 TFT LCD
	Resolution	1920×1080
	Display Color	65K
	Brightness	250 cd/m ²
	Backlight	LED
	LCD Lifetime	50000 Hours
	Touch Screen	4-Wire Industrial Resistive Touch Screen
	CPU	LT2156E:1G ARM Cortex-A8
		LT2156T:4-core 1.2GHz Cortex-A53
	Flash	LT2156E:256M Flash+512 MDDR3
		LT2156T:1GB DDR + 8GB Flash
	RTC	Configured RTC
	Ethernet	2 *10M/100M Self-Adaption
SD CARD	Micro SD (TF) Card	
USB PORT	1*USB Slave 2.0 port; 1*USB Host 2.0 port	
Program Download Method	USB Slave/USB Flash drive/Ethernet	
Serial Communication Port	COM1:RS232/RS485/RS422 ;COM2:RS485/RS422; COM3:RS232	
LCD Viewing Angle (T/B/L/R)	85°/85°/85°/85°	
Electrical Specifications	Rated Power	< 18W
	Rated Voltage	DC24V, Range DC 18V~28V
	Power Protection	Lightning surge protection
	Power-Off Time	< 5ms
	CE & RoHS	EN61000-6-2:2005,EN61000-6-4:2007
Lightning Surge±1KV,Group-Pulse±2KV		
Contact Discharge 4KV,Air Discharge 8KV		
Environmental Requirements	Operating Temperature	0~50°C
	Storage Temperature	-20~60°C
	UV Protection	Do Not Expose The HMI To Environments With Strong UV (Such As Outdoors With Direct Sunlight) For A Long Time
	Operating Humidity	10~90%RH(Without Condensation)
	Vibration Resistance	10~25Hz(X、Y、Z Direction 2G/30 minutes)
	Cooling Method	Air Cooling
Mechanical Characteristics	Installation	Embedded installation/VESA installation
	IP	IP65 For Front Panel And IP20 For Rear Cover
	Mechanical Structure	Aluminum alloy shell
	Cut-Out Mounting	380mm×245mm
	Overall Dimensions	394mm×256mm×36mm Thickness 22mm
	Weight	2250g

Outline Dimensions

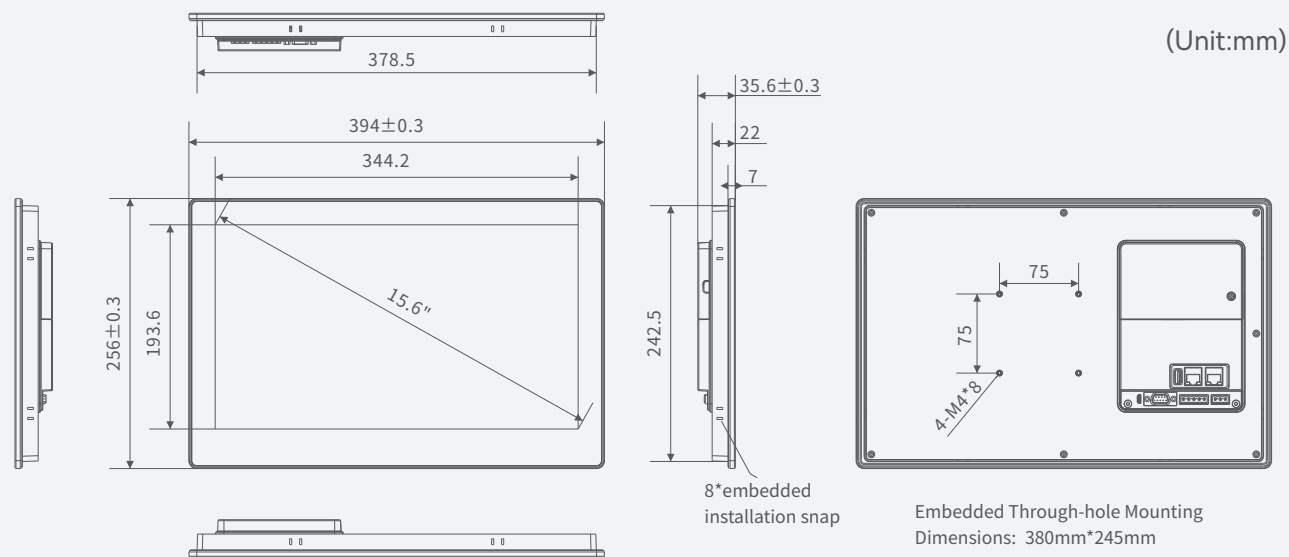

Port Information

No.	Name	Description
①	Power Port	DC 24V
②	RS485 Port	Connection to PLC or other devices
③	DB9 Male	Supports RS232, RS485 for connection to PLC or other devices
④	USB Host	Connect to USB flash drive, code scanning machine etc.
⑤	USB Slave	Used to download programs and debugging
⑥	Ethernet Port	Used for downloading programs or connecting PLC with Ethernet port

Easy to Use Configuration Software LT Studio

Suitable for Various PLCs

Leadshine MC500 and SC5-C series PLC, siemens S7-200/300/SMART 200/1200/1500 series PLC, mitsubishi FX3U series PLC, modbus RTU modbus TCP etc.

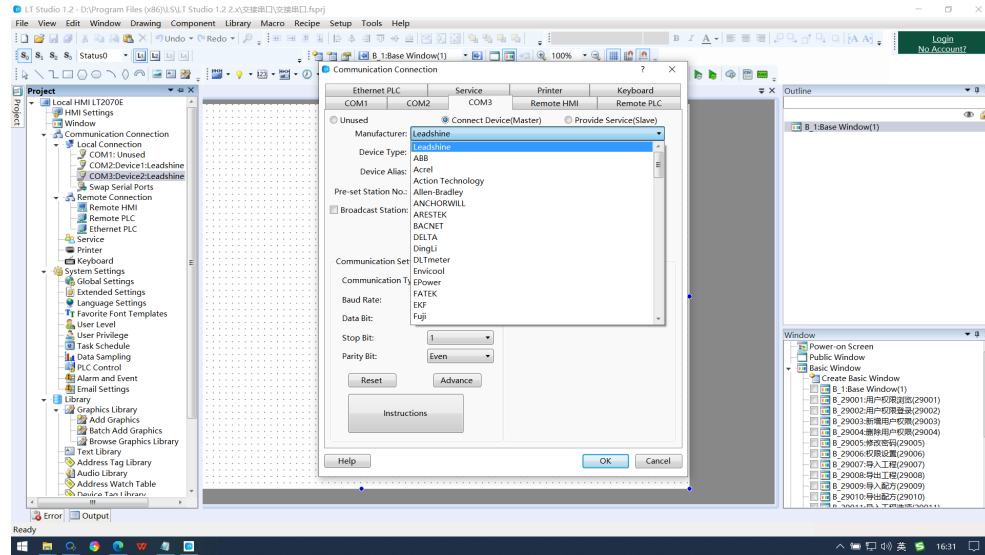

Local Transparent Transmission Function

Local transparent program function can be achieved through the virtual serial port tool provided by LT Studio.

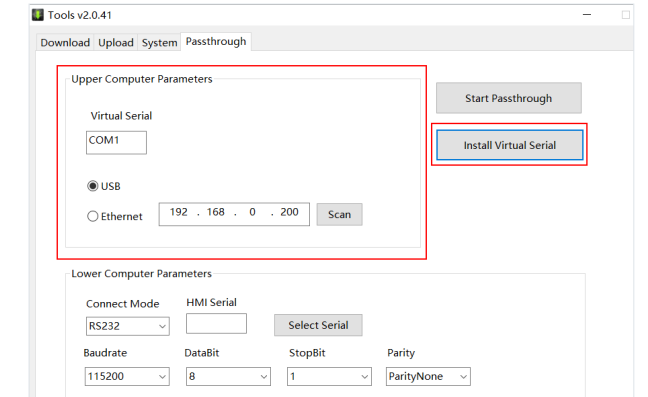
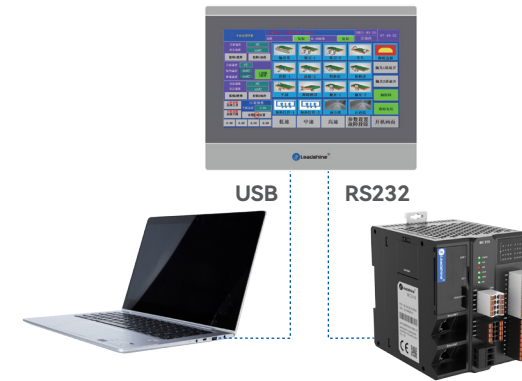

Switching Serial Port Function

Through the serial port switching function, it is possible to switch between three serial ports without the need for reconfiguration to achieve convenient communication switching.

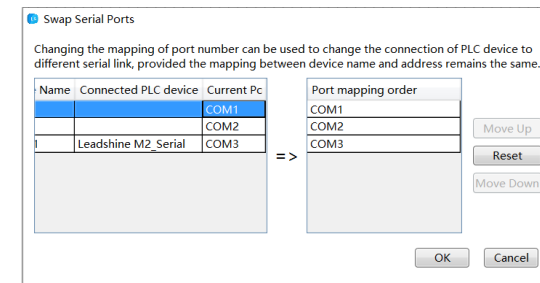

Before Switching

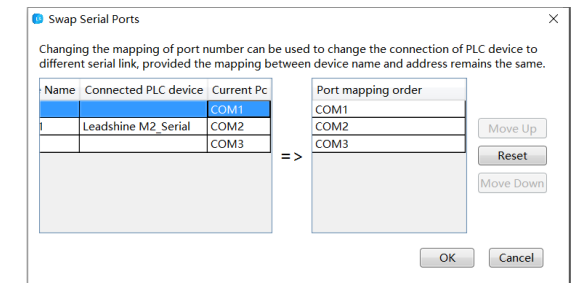

After Switching

Supports multiple languages

The LT studio software interface supports 7 languages, such as English.

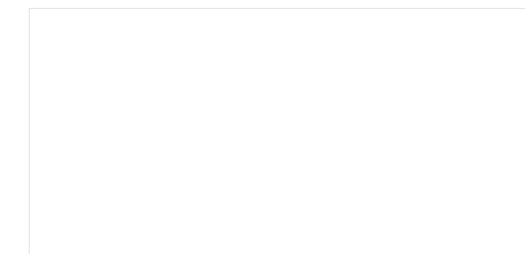

Other functions

Such as formulas, data recording, alarms, keyboard functions, printing functions, text and image libraries, address label libraries and device label libraries, user permissions and user levels, etc.

Macro Instructions Function

Through the macro instruction function based on C language in LT Studio, some functions can be achieved, such as general reading and writing, logic and operation functions, serial port communication, installment payment, export graph functions, etc.

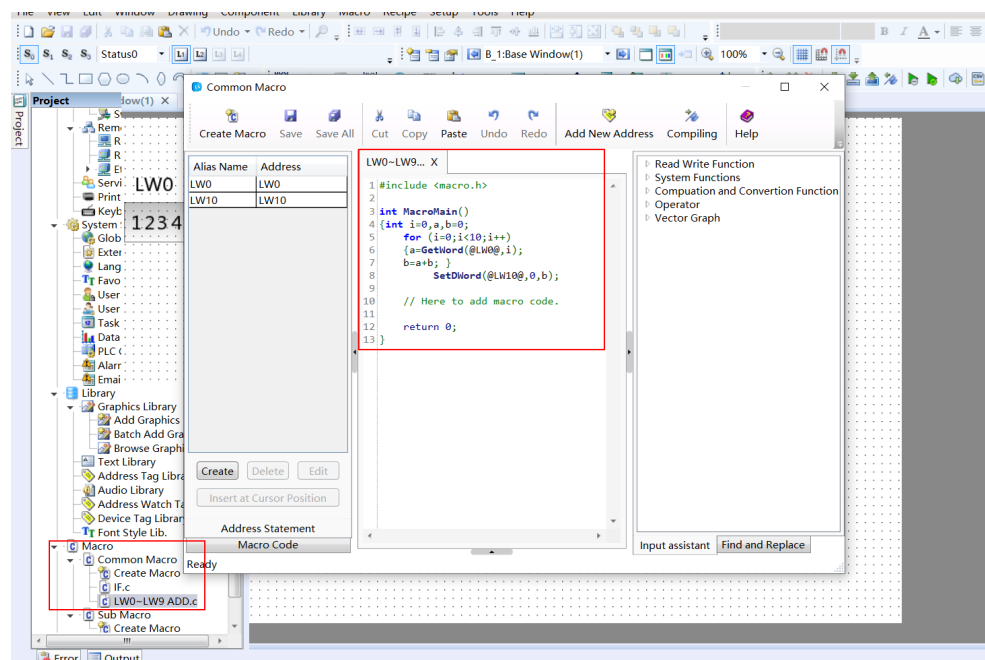

System Selection



Ordering Information

HMI

Series	Model	Describe	Notes
LT2000	LT2043	4.3-Inch Standard HMI	Configuration: Resolution 800 * 480, resistive screen, no Ethernet; COM1(RS232/RS422/RS485),USB*1
	LT2070	7-Inch Standard HMI	Configuration: Resolution 800 * 480, resistive screen, no Ethernet; COM1(RS232/RS422/RS485),COM3(RS232),USB*2
	LT2070E	7-Inch Ethernet HMI	Configuration: Resolution 1024 * 600, resistive screen, with Ethernet; COM1(RS232/RS422/RS485),COM2(RS485),COM3(RS232),USB*2
	LT2070T	7-Inch High-performance HMI	Configuration: Resolution 1024 * 600, resistive screen, with Ethernet, support for tag communication; COM1(RS232/RS422/RS485),COM2(RS485),COM3(RS232),USB*2
	LT2100E	10.1-Inch Ethernet HMI	Configuration: Resolution 1024 * 600, resistive screen, with Ethernet; COM1(RS232/RS422/RS485),COM2(RS485),COM3(RS232),USB*2
	LT2100T	10.1-Inch High-performance HMI	Configuration: Resolution 1024 * 600, resistive screen, with Ethernet, support for tag communication; COM1(RS232/RS422/RS485),COM2(RS485/RS422),COM3(RS232),USB*2
	LT2156E	15.6-Inch Ethernet HMI	Configuration: Resolution 1920 * 1080, resistive screen, with 2 Ethernet interfaces; COM1/COM3(RS232/RS422/RS485),COM2(RS485/RS422),USB*2
	LT2156T	15.6-Inch High-performance HMI	Configuration: Resolution 1920 * 1080, resistive screen, with 2 Ethernet interfaces,support for tag communication; COM1(RS232/RS422/RS485),COM2(RS485/RS422),COM3(RS232),USB*2

Not available

Accessories

Accessories	Describe
CABLE-MPTX3M0_RS232	RS232 Communication cable,optional
LY-DBF-09-040	DB9 female socket, optional
LY-DBWK-09-053	DB9 female outer covering, optional



Headquarters
China Leadshine Technology Co., Ltd.

☎ +86 755 26411692 📠 +86 755 26402718
🌐 www.leadshine.com
✉ sales@leadshine.com (Sales)
 tech@leadshine.com (Technical Support)
📍 15-20/F, Block B, Nanshan i-Valley, Shuguang Community,
 Xili Town, Nanshan District, Shenzhen 518055, China

North America Office
Leadshine America, Inc.

☎ 1-949-608-7270 📠 1-949-638-7298
🌐 www.leadshineusa.com
✉ sales@leadshineusa.com (Sales)
 support@leadshineusa.com (Technical Support)
📍 26050 Towne Centre Dr.Foothill Ranch, CA 92610 USA

