

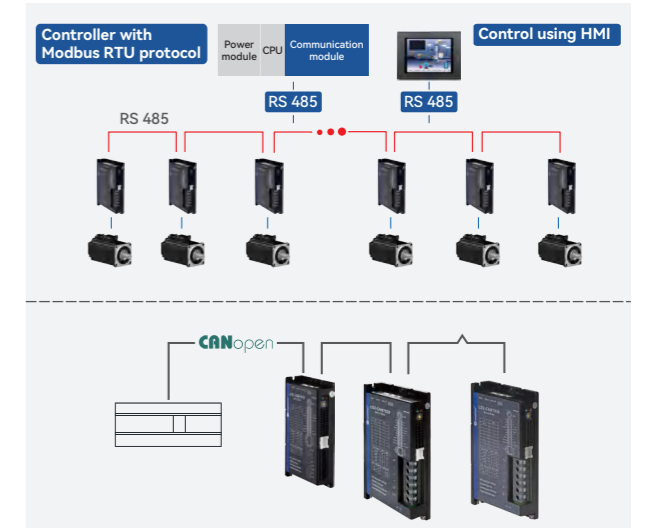

Overview

○ Easier networking between devices

Modbus RTU enables easier networking between devices.



CANopen communication protocol with PDO settings for easier drive setup and 402 observer for drive data monitoring and tuning.



○ Better functions for user convenience

Integrated terminal switch and holding brake power supply make installation much easier.

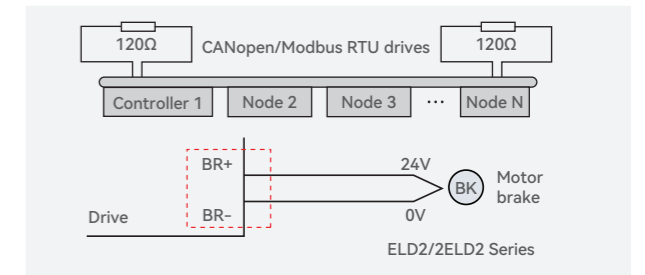

Logic circuit power supply for safer operation. When main power supply is cut off, logic power supply can maintain partial function of DSP and the power supply to activate motor holding brake.

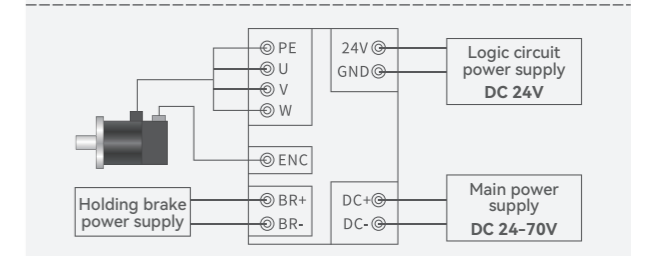

○ Can be matched to many types of motors

Slotless Motor, ELVM Series DC Servo Motor, Brush Motor, Motor with Hall Encoder, Drive wheels.



Single-Axis DC Servo Drive

ELD2 Series

ELD2 Series DC Servo Drive comes with voltage rating of 24 to 70VDC and current rating from 5A up to 60A (max. peak current: 180A). ELD2 series servo drive communication protocol includes CANopen, Modbus RTU, Pulse & Direction and Analogue. These drives provide simplicity to users with functions such as adaptive filters, vibration suppression and safety features such as STO SIL3, Logic Power Circuit.

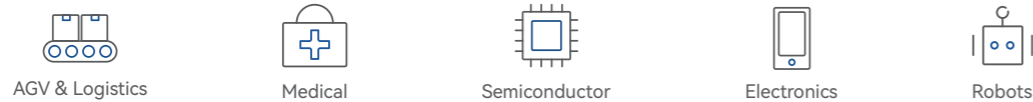

Part Numbers

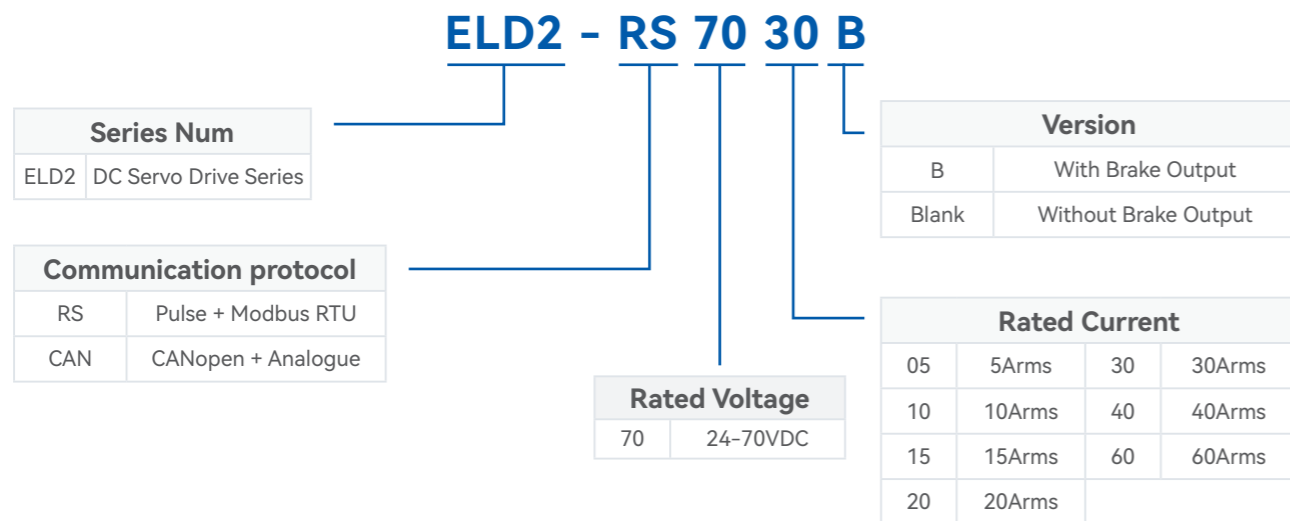

Ports & Connectors

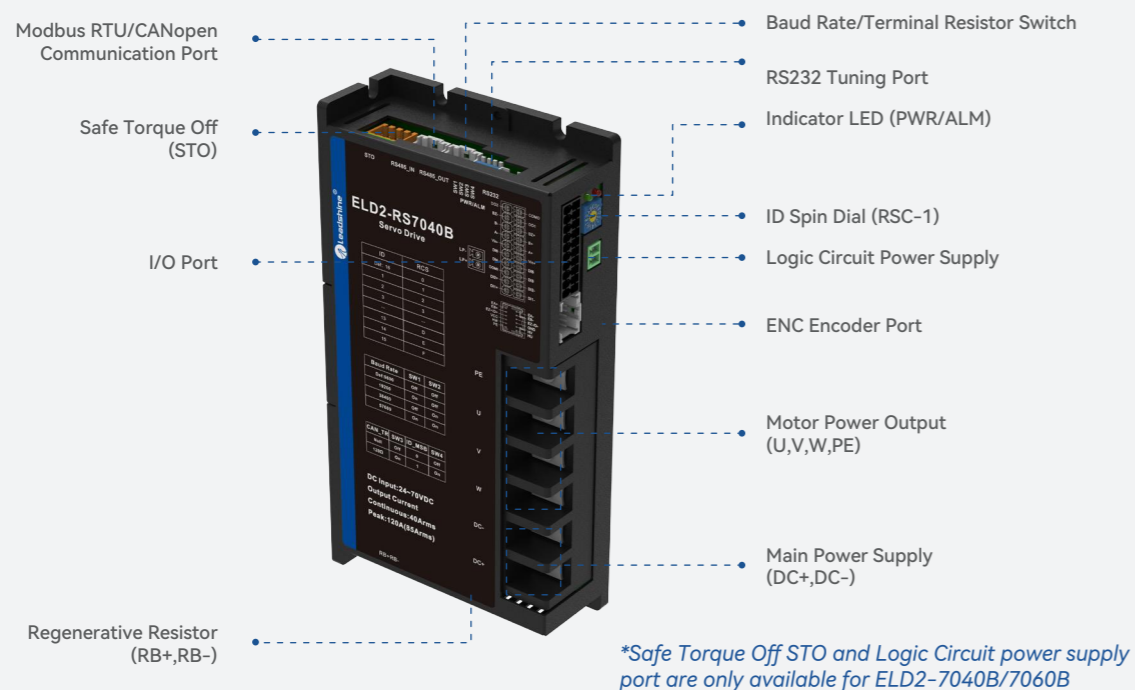

ELD2 & Peripheral Wiring Diagram

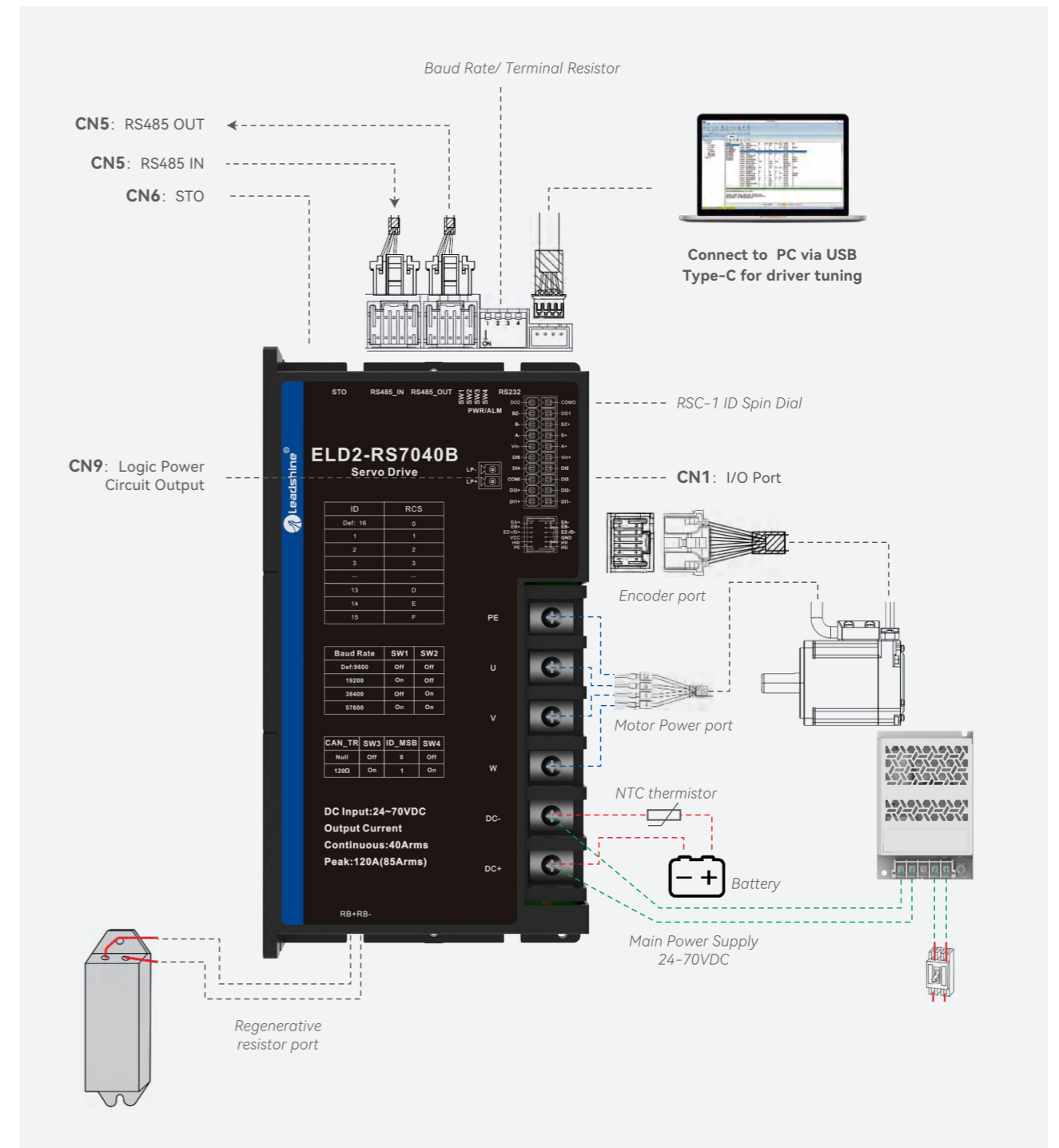

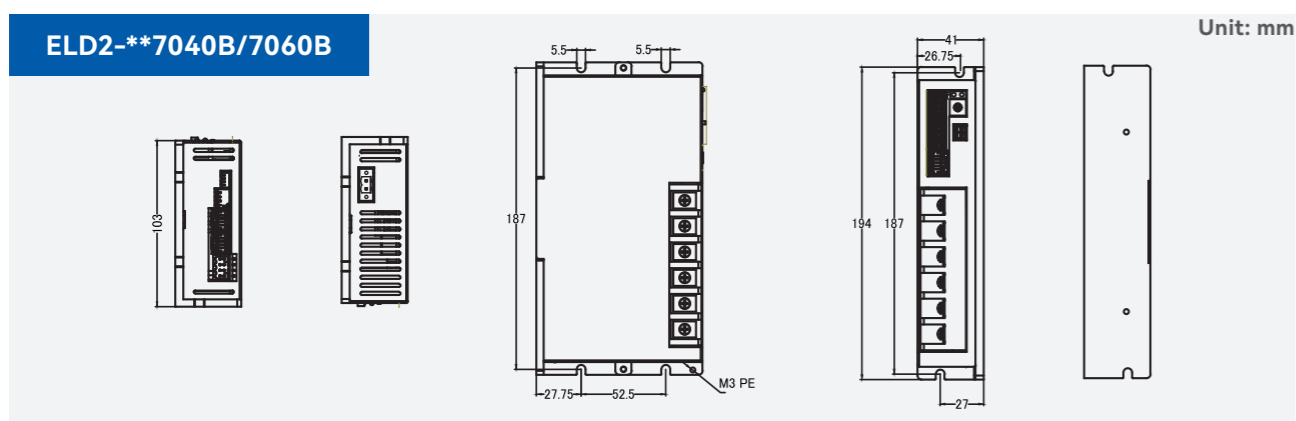
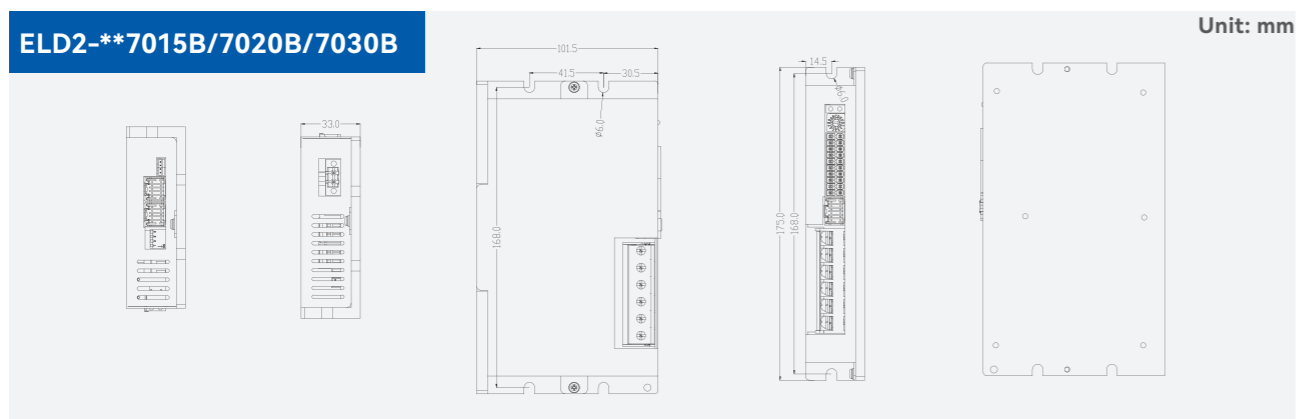
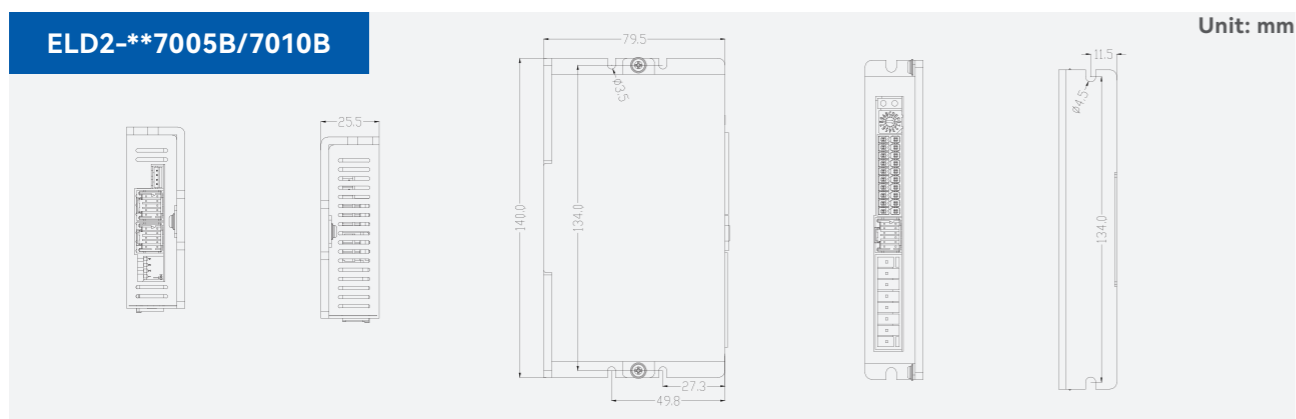
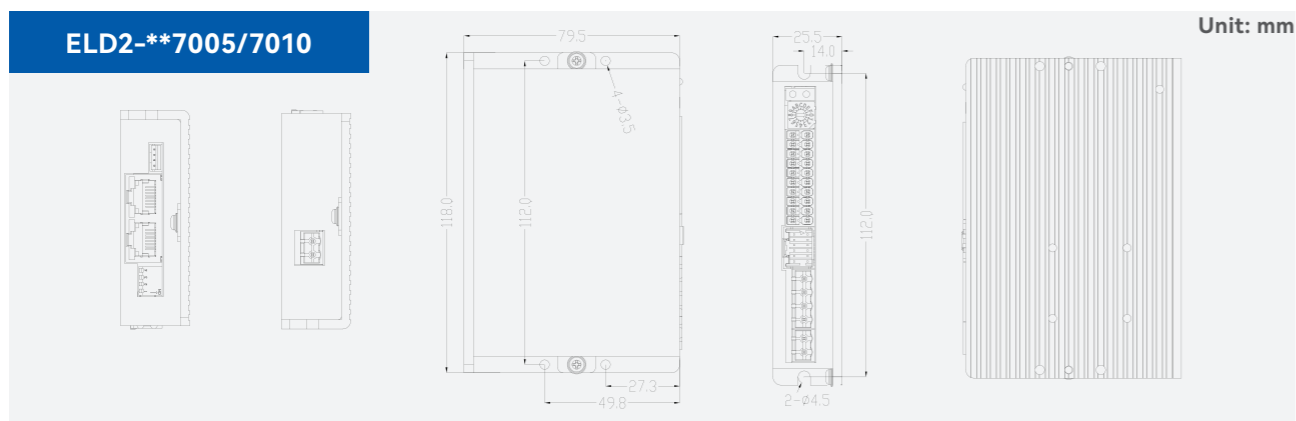

Specifications

ELD2 series	RS7005 CAN7005B	RS7010 CAN7010B	RS7015B CAN7015B	RS7020B CAN7020B	RS7030B CAN7030B
Rated Current (Arms)	5	10	15	20	30
Peak Current (Arms)	21	42	45	80	90
Dimension L*H*W(mm)	118*79.5*25.5	175*100.5*33		168*183*80	

ELD2 series	RS7040B、CAN7040B	RS7060B、CAN7060B
Rated Current (Arms)	40	60
Peak Current (Arms)	120	180
Dimension(mm)	194*103*41	
Logic Power Supply	24VDC	
Safe Torque Off (STO)	STO SIL3	
Main power supply	24 ~ 70VDC	
Direct Drive Holding Brake	Yes	
Drive mode	SVPWM sinusoidal wave drive	
Velocity regulation ratio	5000:1	
Electronic gear ratio	1 ~ 32767/1 ~ 32767	
Matching encoders	Hall signal UVW + ABZ or RS485 encoder (Tamagawa protocol)	
Analog Input	2 analog inputs (AI1/AI2), -10V~+10V, Max. voltage : ±12V - RS models	
Digital Input	2 pulse differential 5V Digital input (Pulse+direction) - RS models 4 configurable NPN/PNP 24V Digital Inputs: DI3-DI6	
Digital Output	1 holding brake output; 2 configurable single-ended NPN/PNP 24V, 8mA digital outputs	
Alarm	Current circuit error, DC bus overvoltage, DC bus undercurrent, overcurrent, overcurrent on IPM, motor overload, regenerative resistor overload, encoder disconnected, encoder initialization error, encoder data error, excessive position deviation, overspeed, I/O configuration error, EEPROM parameter saving CRC checksum error, positive/negative position limit valid, forced alarm input valid	
Indicator light	Red & Green LED	
Tuning Software	Motion Studio 2	
Motion Studio 2	Configure parameters for current, position and velocity loop. Parameter uploading using .lsr parameter files. Drive and motor data monitoring using oscilloscope.	
Communication Port	RS-232, 1: 1; RS485, 0: N (0 ≤ N ≤ 127) , CANopen / Modbus	
Load-Inertia	Smaller than 20 times motor inertia	
Communication Port	Storage condition	Avoid direct sunlight. Keep away from heat generating devices, dust, oil, corrosive liquid/gas and places with strong vibration or high humidity. Prohibit combustible gas and conductive material waste.
	Temperature	-20°C ~ + 45°C (Please allow air circulation if >45°C)
	Storage temperature	-20°C ~ + 65°C
	Humidity	40—90%RH (Condensation free)
	Installation	Vertical and level to ground



Servo Motors

ELVM Series

Feature:

- Power rating: 33W-2kW
- Voltage: 24-48V
- PMSM construction, high efficiency
- Compact design, high overload
- Insulation class: Class F
- Protection level: IP65
- Encoder: 17Bit magnetic encoder / 2500 ppr encoder / 23Bit optical single-turn encoder
- Optional accessory: brake
- Frame size: 25mm, 40mm, 60mm, 80mm, 130mm

○ ELVM-M17 Series

- High inertia
- Max speed 4000rpm
- 17Bit magnetic encoder
- Power: 50W-2kW

○ ELVM-B25 Series

- High inertia
- Max speed 4000rpm
- 2500 ppr encoder
- Power: 50W-1kW

Part Numbers

ELVM - 60 20 V48 E - H - M17 - HD

(1) (2) (3) (4) (5) (6) (7) (8)

(1) Series Num

ELVM	ELVM Series servo motor
------	-------------------------

(2) Frame Size

25	25mm
40	40mm
60	60mm
80	80mm
130	130mm

(3) Rated Output Power

03	33W	05	50W
10	100W	20	200W
40	400W	60	600W
75	750W	100	1000W
120	1200W	150	1500W
200	2000W		

(4) Voltage

V24	24V
V36	36V
V48	48V
V60	60V

(8) Connect type

Blank	Direct connector
HD	Aviation connector-HD

(7) Encoder Type

M17	17Bit magnetic encoder
B25	2500 ppr optical encoder
E23S	23Bit optical single-turn encoder

(6) Inertia Ratio

L	Low
M	Medium
H	High

(5) Motor Type

E	With brake, oil seal
F	No brake, oil seal

25mm Frame size & 33W

Type Name	Frame Size (mm)	Brake	Voltage (VDC)	Power (W)	Speed (rpm)		Torque (Nm)		Current (Arms)		Encoder	Inertia (kgm ² *10 ⁻⁴)	Weight (kg)	Motor Length (mm)
					Rated	Max	Rated	Max	Rated	Max				
2503V24EL-E23S	□ 25	√	24-48	33	3000	6000	0.105	0.315	2.7	8.1	23Bit optical single turn encoder	0.007	0.26	98.5
2503V24FL-E23S		x										0.006	0.19	72.5

Dimensions

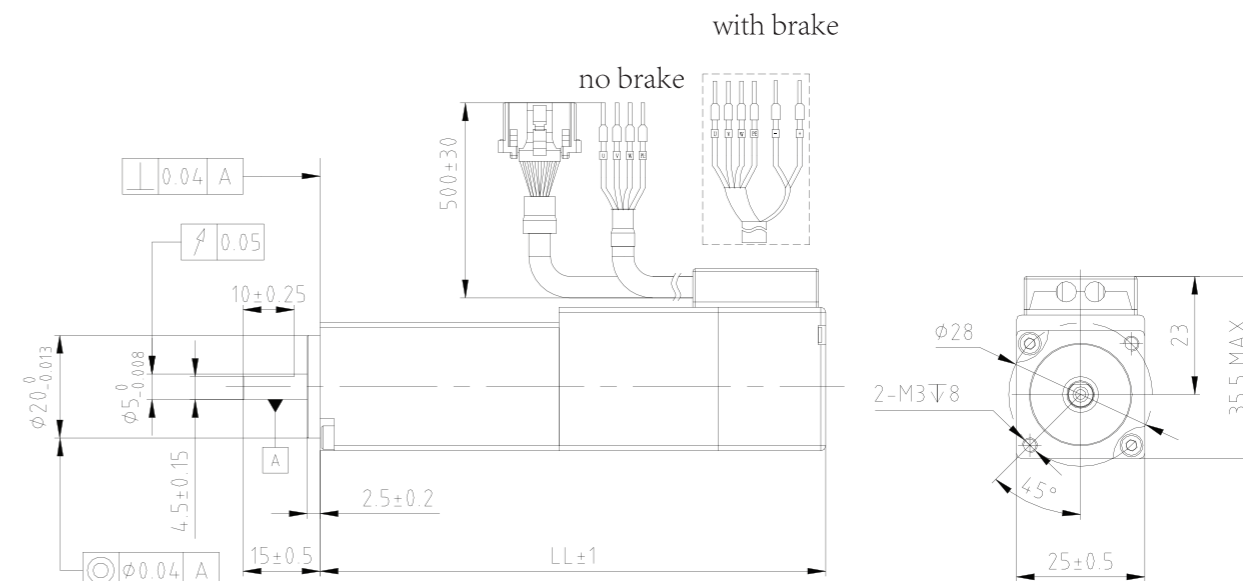

Motor model (ELVM)	LL
2503V24EL-E23S	98.5
2503V24FL-E23S	72.5

40mm Frame size & 50W~100W

Type Name	Frame Size (mm)	Brake	Voltage (VDC)	Power (W)	Speed (rpm)		Torque (Nm)		Current (Arms)		Encoder	Inertia (kgm ² *10 ⁻⁴)	Weight (kg)	Motor Length (mm)							
					Rated	Max	Rated	Max	Rated	Max											
4005V48EH-M17-HD	□ 40	√	24-48	50	3000	4000	0.16	0.48	3	9.3	17Bit multi-turn absolute magnetic encoder	0.046	0.49	84							
4005V48FH-M17-HD		×										0.036	0.33	56.7							
4010V48EH-M17-HD		√										0.32	0.96	5.7	17.7	0.072	0.59	95			
4010V48FH-M17-HD		×														0.062	0.43	67.7			
4005V48EH-B25-HD		√										50	0.16	0.48	3	9.3	0.046	0.49	84		
4005V48FH-B25-HD		×		0.036			0.33	56.7													
4010V48EH-B25-HD		√		0.32			0.96	5.7	17.7	0.072										0.59	95
4010V48FH-B25-HD		×								0.062										0.43	67.7

Speed-Torque characteristics

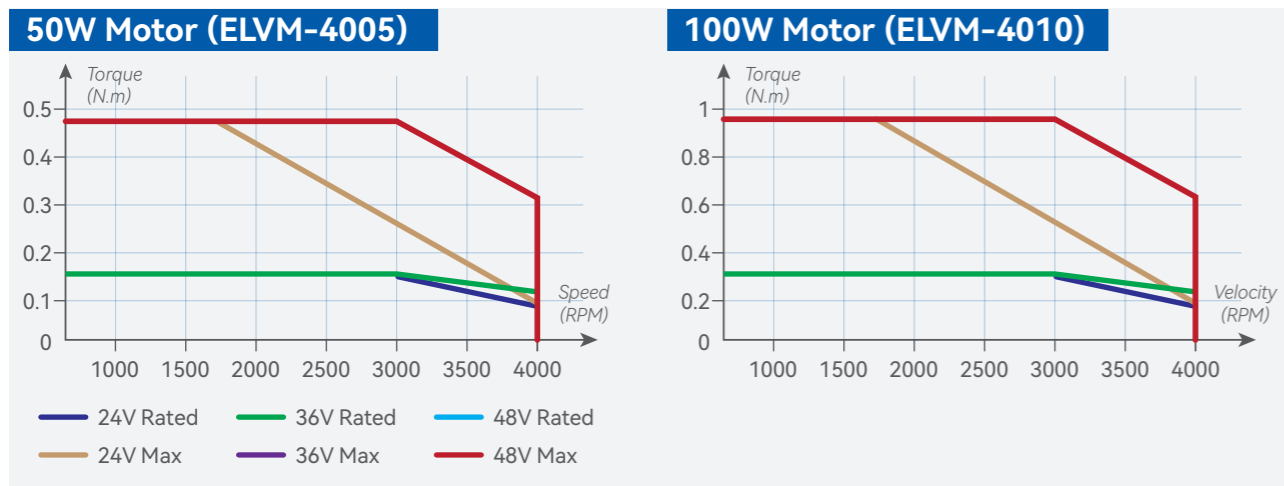

Dimensions

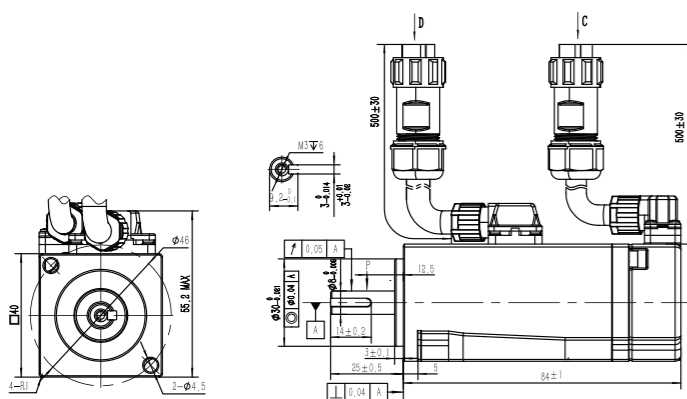

Motor model (ELVM)	LL
4005V48EH-***-HD	84
4005V48FH-***-HD	56.7
4010V48EH-***-HD	95
4010V48FH-***-HD	67.7

60mm Frame size & 200W~600W

Type Name	Frame Size (mm)	Brake	Voltage (VDC)	Power (W)	Speed (rpm)		Torque (Nm)		Current (Arms)		Encoder	Inertia (kgm ² *10 ⁻⁴)	Weight (kg)	Motor Length (mm)								
					Rated	Max	Rated	Max	Rated	Max												
6020V24EH-M17-HD	□ 60	√	24-48	200	3000	4000	0.64	1.92	6	18.6	17Bit multi-turn absolute magnetic encoder	0.3	1.4	101.1								
6020V24FH-M17-HD		×										0.29	1	71.8								
6020V48EH-M17-HD		√										0.32	0.96	5.7	17.7	0.072	0.59	95				
6020V48FH-M17-HD		×														0.062	0.43	67.7				
6040V24EH-M17-HD		√										50	0.16	0.48	3	9.3	0.046	0.49	84			
6040V24FH-M17-HD		×		0.036			0.33	56.7														
6040V48EH-M17-HD		√		0.32			0.96	5.7	17.7	0.072										0.59	95	
6040V48FH-M17-HD		×								0.062										0.43	67.7	
6060V48EH-M17-HD		√		600			1.91	5.73	15	46.5										1.91	5.73	15
6060V48FH-M17-HD		×										0.83	1.74	108.8								
6020V24EH-B25-HD	√	200	0.64		1.92	6					18.6	0.64	1.92	6	18.6							
6020V24FH-B25-HD	×															0.29	1	71.8				
6020V48EH-B25-HD	√															0.32	0.96	5.7	17.7			
6020V48FH-B25-HD	×			0.062			0.43	67.7														
6040V24EH-B25-HD	√			400			1.27	3.81	10	31						1.27	3.81	10	31			
6040V24FH-B25-HD	×	0.58	1.3		88.8																	
6040V48EH-B25-HD	√	0.32	0.96		5.7	17.7					0.072	0.59	95									
6040V48FH-B25-HD	×										0.062	0.43	67.7									
6060V48EH-B25-HD	√	600	1.91		5.73	15					46.5	1.91	5.73	15	46.5							
6060V48FH-B25-HD	×			0.83			1.74	108.8														

Speed-Torque characteristics

200W Motor (ELVM-6020V24)

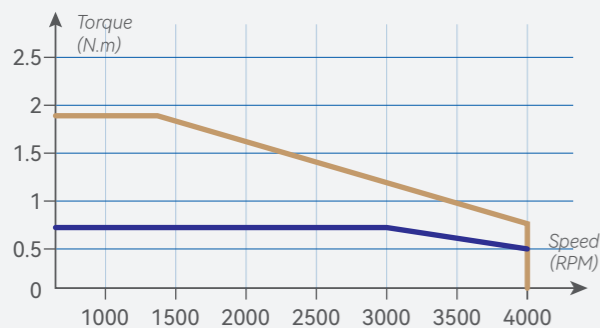

400W Motor (ELVM-6040V24)

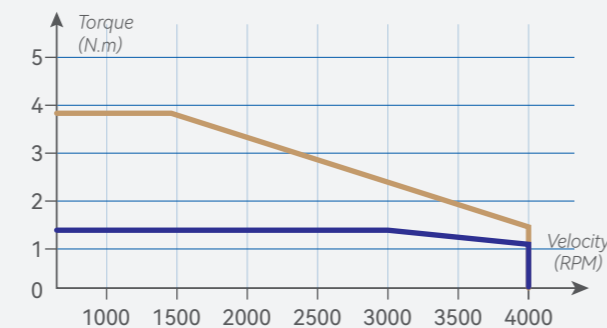

200W Motor (ELVM-6020V48)

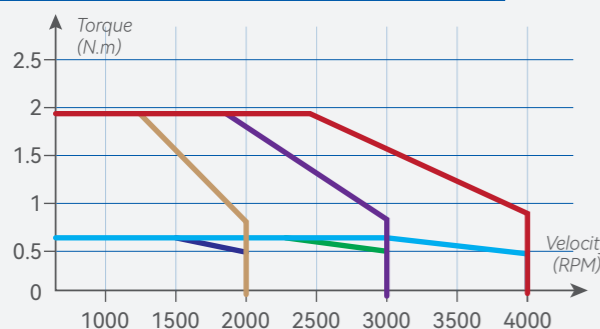

400W Motor (ELVM-6040V48)

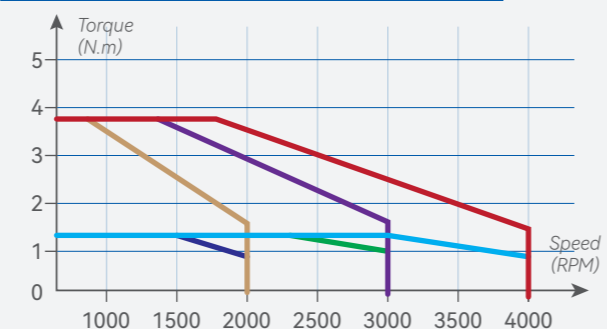

600W Motor (ELVM-6060V48)

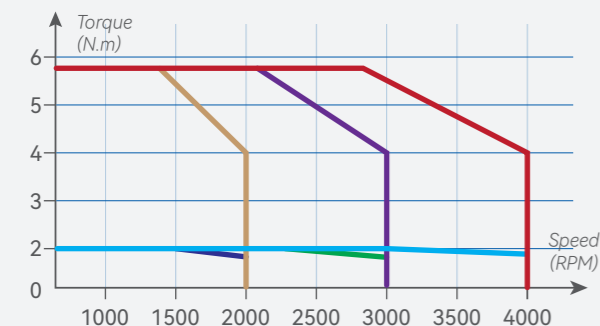

— 24V Rated — 36V Rated — 48V Rated
— 24V Max — 36V Max — 48V Max

Dimensions

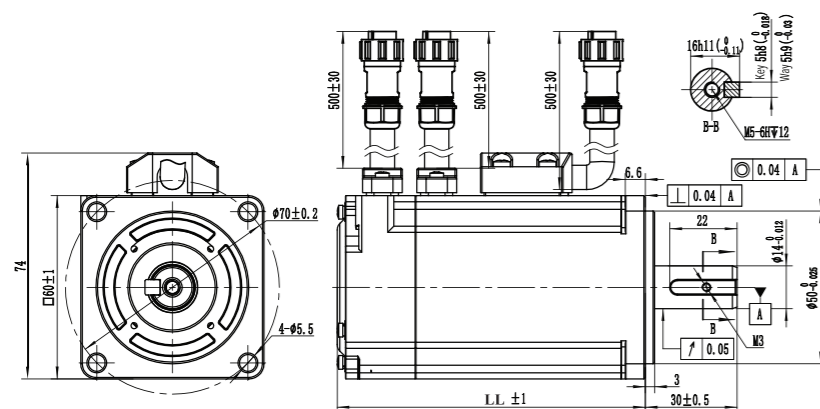

Motor model (ELVM)	LL
6020V**EH-***-HD	101.1
6020V**FH-***-HD	71.8
6040V**EH-***-HD	118.1
6040V**FH-***-HD	88.8
6060V48EH-***-HD	138.1
6060V48FH-***-HD	108.8

80mm Frame size & 750W~1000W

Type Name	Frame Size (mm)	Brake	Voltage (VDC)	Power (W)	Speed (rpm)		Torque (Nm)		Current (Arms)		Encoder	Inertia (kgm ² *10 ⁻⁴)	Weight (kg)	Motor Length (mm)
					Rated	Max	Rated	Max	Rated	Max				
8075V48EH-M17-HD	80	√	48	750	3900	2.39	7.17	19	59	17Bit multi-turn absolute magnetic encoder	1.65	2.7	121.9	
8075V48FH-M17-HD		×									1.5	2.12	90.9	
80100V48EH-M17-HD		√		1000	4000	3.2	9.6	28	87		1.95	3.2	134.9	
80100V48FH-M17-HD		×									1.8	2.8	103.9	
8075V48EH-B25-HD		√	750	3900	2.39	7.17	19	59	2500 ppr increment optical encoder		1.65	2.7	121.9	
8075V48FH-B25-HD		×									1.5	2.12	90.9	
80100V48EH-B25-HD		√		1000	4000	3.2	9.6	28			87	1.95	3.2	134.9
80100V48FH-B25-HD		×										1.8	2.8	103.9

Speed-Torque characteristics

750W Motor (ELVM-8075V48)

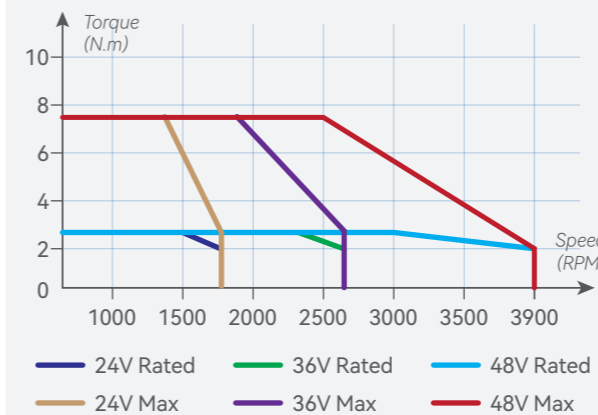

1000W Motor (ELVM-80100V48)

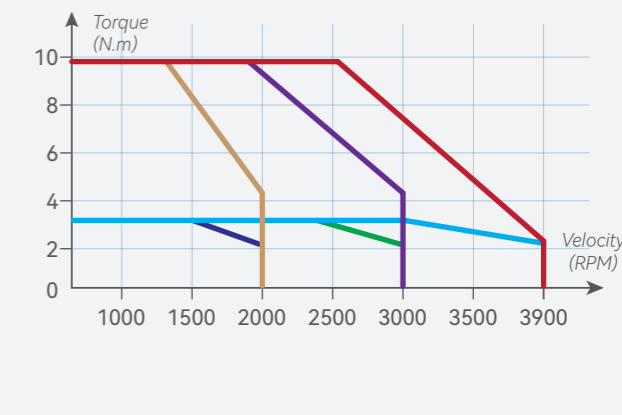

Dimensions

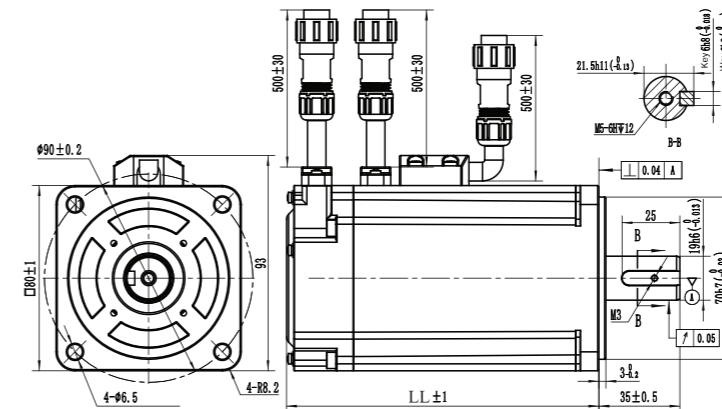

motor model (ELVM)	LL
8075V48EH-***-HD	121.9
8075V48FH-***-HD	90.9
80100V48EH-***-HD	134.9
80100V48FH-***-HD	103.9



130mm Frame size & 1200W~2000W

Type Name	Frame Size (mm)	Brake	Voltage (VDC)	Power (W)	Speed (rpm)		Torque (Nm)		Current (Arms)		Encoder	Inertia ($\text{kgm}^2 \cdot 10^{-4}$)	Weight (kg)	Motor Length (mm)
					Rated	Max	Rated	Max	Rated	Max				
130120V48EM-M17-HD	130	✓	48	1200	3000	4000	3.8	10	30	79	17Bit multi-turn absolute magnetic encoder	13.3	6.5	174
130120V48FM-M17-HD		×										11.63	5.2	151
130150V48EM-M17-HD		✓	2000	1500	3000	4000	4.8	12.5	37.5	98		15.55	6.9	180
130150V48FM-M17-HD		×										13.88	5.6	157
130200V48EM-M17-HD		✓										17.71	7.7	187
130200V48FM-M17-HD		×										16.04	6.4	164

Speed-Torque characteristics

1200W Motor (ELVM-130120V48)

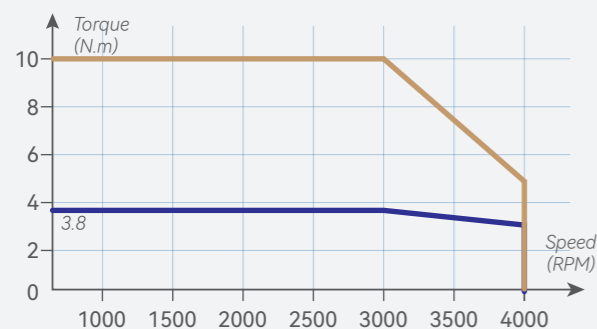

1500W Motor (ELVM-130150V48)

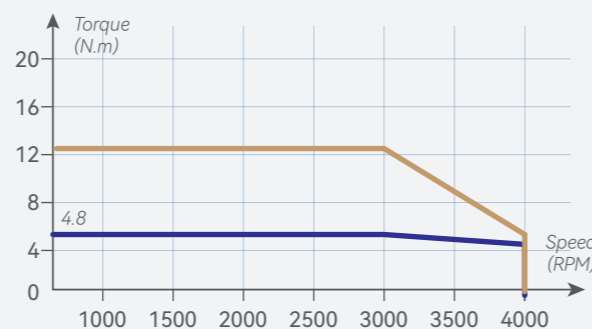

2000W Motor (ELVM-130200V48)

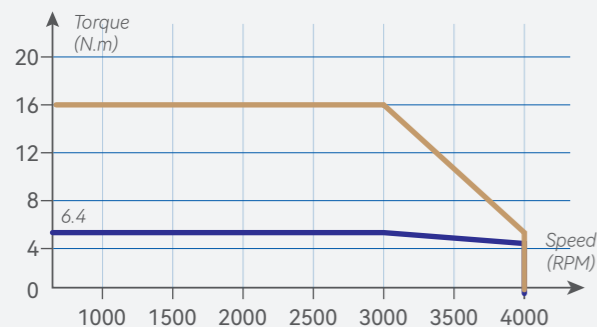

— 24V Rated — 36V Rated — 48V Rated
— 24V Max — 36V Max — 48V Max

Dimensions

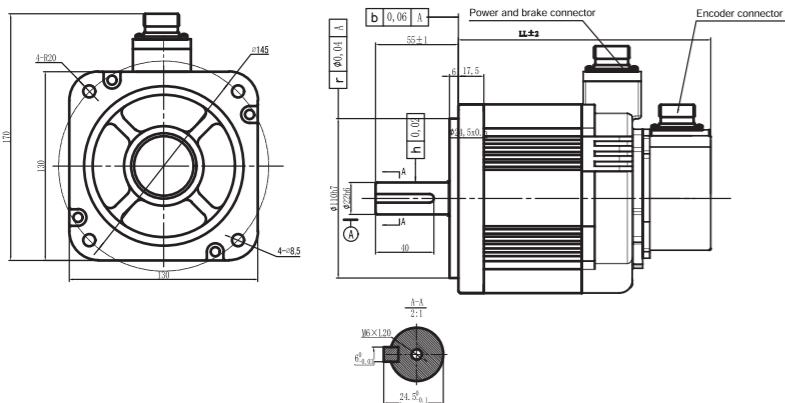

Motor model (ELVM)	LL
130120V48EM-M17-HD	174
130120V48FM-M17-HD	151
130150V48EM-M17-HD	180
130150V48FM-M17-HD	157
130200V48EM-M17-HD	187
130200V48FM-M17-HD	164

Cable Selection

The cables which are available for our 2ELD2/ELD2 series servo drives and ELVM series servo motors are listed in detail in this section including a comprehensive guide on how to match the right cables to the drives and motors.

For our 2ELD2/ELD2 series servo drives, an CABLE-PC-1 tuning cable is optionally provided to connect the drives to a PC for tuning purposes.

Motor power supply cables (including motor brake cables) and encoder cables are matched with our ELVM series servo motors. The cables are matched to the servo motors based on motor series and frame sizes.

Servo Drive Cables

Communication cable	CABLE-TX*M*-LD2	<p>*M* represents the length of the cables. For example, 1M5 = 1.5 meters Available length: 0.3M, 0.5M, 1.0M, 1.5M, 3M, 5M, 7M, 10M</p>
Tuning cable	CABLE-PC-1	<p>1500 ± 20</p>

Motor cable model number

CABLE RZS H 3M0 - 1 1 3 - T - R

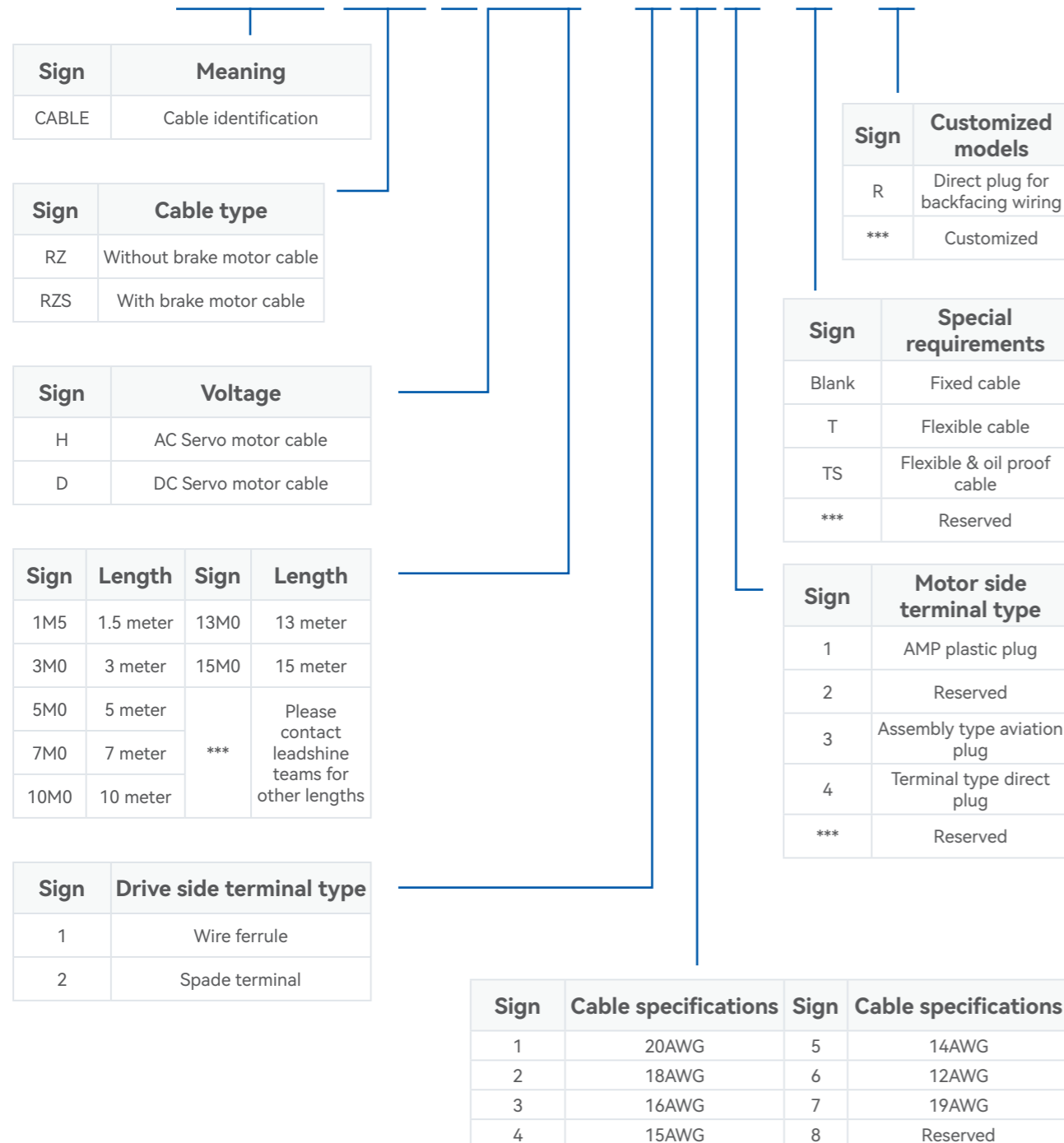

Encoder cable model number

CABLE BMA H 3M0 - 1 1 3 - T - R

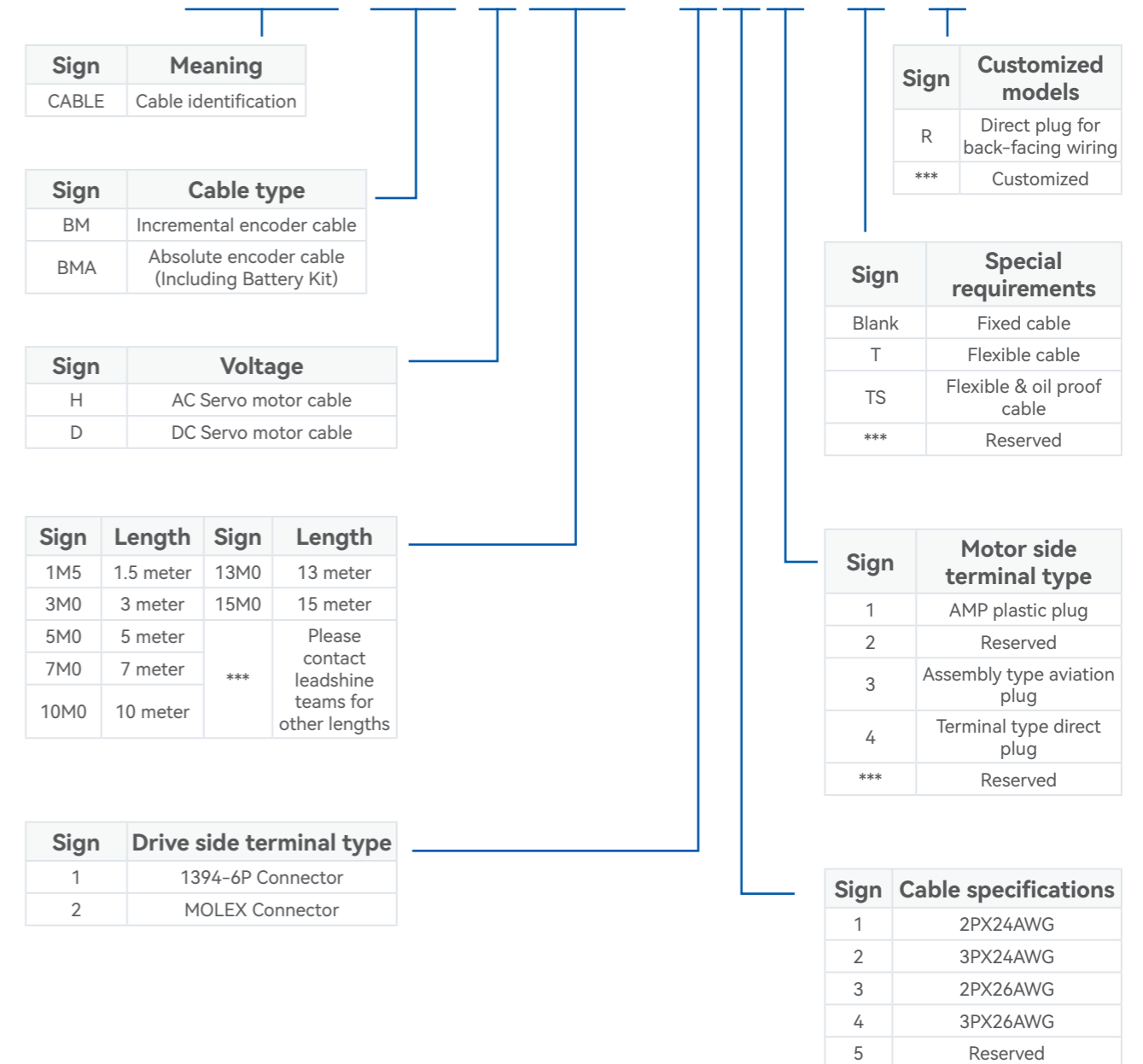

Motor cable model number

CABLE - SC H 3M0 - 1 1 3 - T

Sign	Meaning
CABLE	Cable identification

Sign	Cable type
SC	Brake cable
***	Reserved

Sign	Voltage
H	AC Servo motor cable
D	DC Servo motor cable

Sign	Length	Sign	Length
1M5	1.5 meter	13M0	13 meter
3M0	3 meter	15M0	15 meter
5M0	5 meter	***	Please contact leadshine teams for other lengths
7M0	7 meter		
10M0	10 meter		

Sign	Drive side terminal type
1	Wire ferrule
***	Reserved

Sign	Special requirements
Blank	Fixed cable
T	Flexible cable
TS	Flexible & oil proof cable
***	Reserved

Sign	Motor side terminal type
1	AMP plastic plug
2	Reserved
3	Assembly type aviation plug
4	Terminal type direct plug
***	Reserved

Sign	Cable specifications
1	2X0.3mm ²
***	Reserved

ELVM Series - 40mm



- Frame size: 40mm
- Power rating: 50W-100W
- Motor model: ELVM40**V48*H-***-HD

Cable Type	Diagram	Pin																																																
Motor power	Without brake CABLE-RZD*M*-123	 1 Red U 2 Blue V 3 Brown W 4 Yellow Green PE 5* Black 0V 6* White 24V <small>*5&6 terminal for motor with brake</small>																																																
	With brake CABLE-RZSD*M*-123	 1 Red U 2 Blue V 3 Brown W 4 Yellow Green PE 5* Black 0V 6* White 24V <small>*5&6 terminal for motor with brake</small>																																																
Motor encoder	Incremental CABLE-BMD*M*-213 (17Bit magnetic encoder)	 A Terminal B 1 PE 1 2 5V 5 3 0V 6 4 SD+ 7 5 SD- 8 6* BAT+ - 7* BAT- - <small>*Terminal 6 & 7 is to be connected to battery kit for absolute encoder</small>																																																
	Absolute CABLE-BMAD*M*-223 (17Bit magnetic encoder)	 A Terminal B 1 PE 1 2 5V 5 3 0V 6 4 SD+ 7 5 SD- 8 6* BAT+ - 7* BAT- - <small>*Terminal 6 & 7 is to be connected to battery kit for absolute encoder</small>																																																
	 CABLE-LD2-BM*M* (2500 ppr encoder)	 12 11 2 1																																																
		<table border="1"> <tr> <td>PIN-A</td> <td>1</td> <td>2</td> <td>3</td> <td>4</td> <td>5</td> <td>6</td> <td>7</td> <td>8</td> <td>9</td> <td>10</td> <td>11</td> <td>12</td> <td>13</td> <td>14</td> <td>15</td> </tr> <tr> <td>PIN-B</td> <td>11</td> <td>9</td> <td>6</td> <td>3</td> <td>2</td> <td>1</td> <td>7</td> <td>8</td> <td>4</td> <td>-</td> <td>12</td> <td>10</td> <td>5</td> <td>-</td> <td>-</td> </tr> <tr> <td>Signal</td> <td>A+</td> <td>B+</td> <td>0V</td> <td>W+</td> <td>U+</td> <td>PE</td> <td>Z+</td> <td>Z-</td> <td>V+</td> <td>V-</td> <td>A-</td> <td>B-</td> <td>+5V</td> <td>W-</td> <td>U-</td> </tr> </table>	PIN-A	1	2	3	4	5	6	7	8	9	10	11	12	13	14	15	PIN-B	11	9	6	3	2	1	7	8	4	-	12	10	5	-	-	Signal	A+	B+	0V	W+	U+	PE	Z+	Z-	V+	V-	A-	B-	+5V	W-	U-
PIN-A	1	2	3	4	5	6	7	8	9	10	11	12	13	14	15																																			
PIN-B	11	9	6	3	2	1	7	8	4	-	12	10	5	-	-																																			
Signal	A+	B+	0V	W+	U+	PE	Z+	Z-	V+	V-	A-	B-	+5V	W-	U-																																			

ELVM Series - 60mm



- Frame size: 60mm
- Power rating: 200W (48V)
- Motor model: ELVM6020V48*H-***-HD

Cable Type	Diagram	Pin																																															
Motor power	 CABLE-RZD*M*-123	 <table border="1"> <tr><td>1</td><td>Red</td><td>U</td></tr> <tr><td>2</td><td>Blue</td><td>V</td></tr> <tr><td>3</td><td>Brown</td><td>W</td></tr> <tr><td>4</td><td>Yellow Green</td><td>PE</td></tr> </table>	1	Red	U	2	Blue	V	3	Brown	W	4	Yellow Green	PE																																			
1	Red	U																																															
2	Blue	V																																															
3	Brown	W																																															
4	Yellow Green	PE																																															
Motor brake	 CABLE-SCD*M*-113	 <table border="1"> <tr><td>1</td><td>Red</td><td>24V</td></tr> <tr><td>2</td><td>Black</td><td>0V</td></tr> </table>	1	Red	24V	2	Black	0V																																									
1	Red	24V																																															
2	Black	0V																																															
Motor encoder	Incremental CABLE-BMD*M*-213 (17Bit magnetic encoder)	 <table border="1"> <tr><td>A</td><td>Terminal</td><td>B</td></tr> <tr><td>1</td><td>PE</td><td>1</td></tr> <tr><td>2</td><td>5V</td><td>5</td></tr> <tr><td>3</td><td>0V</td><td>6</td></tr> <tr><td>4</td><td>SD+</td><td>7</td></tr> <tr><td>5</td><td>SD-</td><td>8</td></tr> <tr><td>6*</td><td>BAT+</td><td>-</td></tr> <tr><td>7*</td><td>BAT-</td><td>-</td></tr> </table>	A	Terminal	B	1	PE	1	2	5V	5	3	0V	6	4	SD+	7	5	SD-	8	6*	BAT+	-	7*	BAT-	-																							
	A	Terminal	B																																														
	1	PE	1																																														
2	5V	5																																															
3	0V	6																																															
4	SD+	7																																															
5	SD-	8																																															
6*	BAT+	-																																															
7*	BAT-	-																																															
Absolute CABLE-BMAD*M*-223 (17Bit magnetic encoder)	 <table border="1"> <tr><td>A</td><td>Terminal</td><td>B</td></tr> <tr><td>1</td><td>PE</td><td>1</td></tr> <tr><td>2</td><td>5V</td><td>5</td></tr> <tr><td>3</td><td>0V</td><td>6</td></tr> <tr><td>4</td><td>SD+</td><td>7</td></tr> <tr><td>5</td><td>SD-</td><td>8</td></tr> <tr><td>6*</td><td>BAT+</td><td>-</td></tr> <tr><td>7*</td><td>BAT-</td><td>-</td></tr> </table>	A	Terminal	B	1	PE	1	2	5V	5	3	0V	6	4	SD+	7	5	SD-	8	6*	BAT+	-	7*	BAT-	-																								
A	Terminal	B																																															
1	PE	1																																															
2	5V	5																																															
3	0V	6																																															
4	SD+	7																																															
5	SD-	8																																															
6*	BAT+	-																																															
7*	BAT-	-																																															
 CABLE-LD2-BM*M* (2500 ppr encoder)	 <table border="1"> <tr><td>PIN-A</td><td>1</td><td>2</td><td>3</td><td>4</td><td>5</td><td>6</td><td>7</td><td>8</td><td>9</td><td>10</td><td>11</td><td>12</td><td>13</td><td>14</td><td>15</td></tr> <tr><td>PIN-B</td><td>11</td><td>9</td><td>6</td><td>3</td><td>2</td><td>1</td><td>7</td><td>8</td><td>4</td><td>-</td><td>12</td><td>10</td><td>5</td><td>-</td><td>-</td></tr> <tr><td>Signal</td><td>A+</td><td>B+</td><td>0V</td><td>W+</td><td>U+</td><td>PE</td><td>Z+</td><td>Z-</td><td>V+</td><td>V-</td><td>A-</td><td>B-</td><td>+5V</td><td>W-</td><td>U-</td></tr> </table>	PIN-A	1	2	3	4	5	6	7	8	9	10	11	12	13	14	15	PIN-B	11	9	6	3	2	1	7	8	4	-	12	10	5	-	-	Signal	A+	B+	0V	W+	U+	PE	Z+	Z-	V+	V-	A-	B-	+5V	W-	U-
PIN-A	1	2	3	4	5	6	7	8	9	10	11	12	13	14	15																																		
PIN-B	11	9	6	3	2	1	7	8	4	-	12	10	5	-	-																																		
Signal	A+	B+	0V	W+	U+	PE	Z+	Z-	V+	V-	A-	B-	+5V	W-	U-																																		

ELVM Series - 60mm



- Frame size: 60mm
- Power rating: 200W(24V)&400W(48V)
- Motor model: ELVM6020V24*H-***-HD/ELVM6040V48*H-***-HD

Cable Type	Diagram	Pin																																															
Motor power	 CABLE-RZD*M*-143	 <table border="1"> <tr><td>1</td><td>Red</td><td>U</td></tr> <tr><td>2</td><td>Blue</td><td>V</td></tr> <tr><td>3</td><td>Brown</td><td>W</td></tr> <tr><td>4</td><td>Yellow Green</td><td>PE</td></tr> </table>	1	Red	U	2	Blue	V	3	Brown	W	4	Yellow Green	PE																																			
1	Red	U																																															
2	Blue	V																																															
3	Brown	W																																															
4	Yellow Green	PE																																															
Motor brake	 CABLE-SCD*M*-113	 <table border="1"> <tr><td>1</td><td>Red</td><td>24V</td></tr> <tr><td>2</td><td>Black</td><td>0V</td></tr> </table>	1	Red	24V	2	Black	0V																																									
1	Red	24V																																															
2	Black	0V																																															
Motor encoder	Incremental CABLE-BMD*M*-213 (17Bit magnetic encoder)	 <table border="1"> <tr><td>A</td><td>Terminal</td><td>B</td></tr> <tr><td>1</td><td>PE</td><td>1</td></tr> <tr><td>2</td><td>5V</td><td>5</td></tr> <tr><td>3</td><td>0V</td><td>6</td></tr> <tr><td>4</td><td>SD+</td><td>7</td></tr> <tr><td>5</td><td>SD-</td><td>8</td></tr> <tr><td>6*</td><td>BAT+</td><td>-</td></tr> <tr><td>7*</td><td>BAT-</td><td>-</td></tr> </table>	A	Terminal	B	1	PE	1	2	5V	5	3	0V	6	4	SD+	7	5	SD-	8	6*	BAT+	-	7*	BAT-	-																							
	A	Terminal	B																																														
	1	PE	1																																														
2	5V	5																																															
3	0V	6																																															
4	SD+	7																																															
5	SD-	8																																															
6*	BAT+	-																																															
7*	BAT-	-																																															
Absolute CABLE-BMAD*M*-223 (17Bit magnetic encoder)	 <table border="1"> <tr><td>A</td><td>Terminal</td><td>B</td></tr> <tr><td>1</td><td>PE</td><td>1</td></tr> <tr><td>2</td><td>5V</td><td>5</td></tr> <tr><td>3</td><td>0V</td><td>6</td></tr> <tr><td>4</td><td>SD+</td><td>7</td></tr> <tr><td>5</td><td>SD-</td><td>8</td></tr> <tr><td>6*</td><td>BAT+</td><td>-</td></tr> <tr><td>7*</td><td>BAT-</td><td>-</td></tr> </table>	A	Terminal	B	1	PE	1	2	5V	5	3	0V	6	4	SD+	7	5	SD-	8	6*	BAT+	-	7*	BAT-	-																								
A	Terminal	B																																															
1	PE	1																																															
2	5V	5																																															
3	0V	6																																															
4	SD+	7																																															
5	SD-	8																																															
6*	BAT+	-																																															
7*	BAT-	-																																															
 CABLE-LD2-BM*M* (2500 ppr encoder)	 <table border="1"> <tr><td>PIN-A</td><td>1</td><td>2</td><td>3</td><td>4</td><td>5</td><td>6</td><td>7</td><td>8</td><td>9</td><td>10</td><td>11</td><td>12</td><td>13</td><td>14</td><td>15</td></tr> <tr><td>PIN-B</td><td>11</td><td>9</td><td>6</td><td>3</td><td>2</td><td>1</td><td>7</td><td>8</td><td>4</td><td>-</td><td>12</td><td>10</td><td>5</td><td>-</td><td>-</td></tr> <tr><td>Signal</td><td>A+</td><td>B+</td><td>0V</td><td>W+</td><td>U+</td><td>PE</td><td>Z+</td><td>Z-</td><td>V+</td><td>V-</td><td>A-</td><td>B-</td><td>+5V</td><td>W-</td><td>U-</td></tr> </table>	PIN-A	1	2	3	4	5	6	7	8	9	10	11	12	13	14	15	PIN-B	11	9	6	3	2	1	7	8	4	-	12	10	5	-	-	Signal	A+	B+	0V	W+	U+	PE	Z+	Z-	V+	V-	A-	B-	+5V	W-	U-
PIN-A	1	2	3	4	5	6	7	8	9	10	11	12	13	14	15																																		
PIN-B	11	9	6	3	2	1	7	8	4	-	12	10	5	-	-																																		
Signal	A+	B+	0V	W+	U+	PE	Z+	Z-	V+	V-	A-	B-	+5V	W-	U-																																		

ELVM Series - 60mm&80mm



- Frame size: 60mm&80mm
- Power rating: 400W(24V)&600W&750W
- Motor model: ELVM6040V24*H-***-HD/ELVM6060V48*H-***-HD/ELVM8075V48*H-***-HD

Cable Type	Diagram	Pin																																															
Motor power	 CABLE-RZD*M*-253	 <table border="1"> <tr><td>1</td><td>Red</td><td>U</td></tr> <tr><td>2</td><td>Blue</td><td>V</td></tr> <tr><td>3</td><td>Brown</td><td>W</td></tr> <tr><td>4</td><td>Yellow Green</td><td>PE</td></tr> </table>	1	Red	U	2	Blue	V	3	Brown	W	4	Yellow Green	PE																																			
1	Red	U																																															
2	Blue	V																																															
3	Brown	W																																															
4	Yellow Green	PE																																															
Motor brake	 CABLE-SCD*M*-113	 <table border="1"> <tr><td>1</td><td>Red</td><td>24V</td></tr> <tr><td>2</td><td>Black</td><td>0V</td></tr> </table>	1	Red	24V	2	Black	0V																																									
1	Red	24V																																															
2	Black	0V																																															
Motor encoder	Incremental CABLE-BMD*M*-213 (17Bit magnetic encoder)	 <table border="1"> <tr><td>A</td><td>Terminal</td><td>B</td></tr> <tr><td>1</td><td>PE</td><td>1</td></tr> <tr><td>2</td><td>5V</td><td>5</td></tr> <tr><td>3</td><td>0V</td><td>6</td></tr> <tr><td>4</td><td>SD+</td><td>7</td></tr> <tr><td>5</td><td>SD-</td><td>8</td></tr> <tr><td>6*</td><td>BAT+</td><td>-</td></tr> <tr><td>7*</td><td>BAT-</td><td>-</td></tr> </table>	A	Terminal	B	1	PE	1	2	5V	5	3	0V	6	4	SD+	7	5	SD-	8	6*	BAT+	-	7*	BAT-	-																							
	A	Terminal	B																																														
	1	PE	1																																														
2	5V	5																																															
3	0V	6																																															
4	SD+	7																																															
5	SD-	8																																															
6*	BAT+	-																																															
7*	BAT-	-																																															
Absolute CABLE-BMAD*M*-223 (17Bit magnetic encoder)	 <table border="1"> <tr><td>A</td><td>Terminal</td><td>B</td></tr> <tr><td>1</td><td>PE</td><td>1</td></tr> <tr><td>2</td><td>5V</td><td>5</td></tr> <tr><td>3</td><td>0V</td><td>6</td></tr> <tr><td>4</td><td>SD+</td><td>7</td></tr> <tr><td>5</td><td>SD-</td><td>8</td></tr> <tr><td>6*</td><td>BAT+</td><td>-</td></tr> <tr><td>7*</td><td>BAT-</td><td>-</td></tr> </table> <p>*Terminal 6 & 7 is to be connected to battery kit for absolute encoder</p>	A	Terminal	B	1	PE	1	2	5V	5	3	0V	6	4	SD+	7	5	SD-	8	6*	BAT+	-	7*	BAT-	-																								
A	Terminal	B																																															
1	PE	1																																															
2	5V	5																																															
3	0V	6																																															
4	SD+	7																																															
5	SD-	8																																															
6*	BAT+	-																																															
7*	BAT-	-																																															
 CABLE-LD2-BM*M* (2500 ppr encoder)	 <table border="1"> <tr><td>PIN-A</td><td>1</td><td>2</td><td>3</td><td>4</td><td>5</td><td>6</td><td>7</td><td>8</td><td>9</td><td>10</td><td>11</td><td>12</td><td>13</td><td>14</td><td>15</td></tr> <tr><td>PIN-B</td><td>11</td><td>9</td><td>6</td><td>3</td><td>2</td><td>1</td><td>7</td><td>8</td><td>4</td><td>-</td><td>12</td><td>10</td><td>5</td><td>-</td><td>-</td></tr> <tr><td>Signal</td><td>A+</td><td>B+</td><td>0V</td><td>W+</td><td>U+</td><td>PE</td><td>Z+</td><td>Z-</td><td>V+</td><td>V-</td><td>A-</td><td>B-</td><td>+5V</td><td>W-</td><td>U-</td></tr> </table>	PIN-A	1	2	3	4	5	6	7	8	9	10	11	12	13	14	15	PIN-B	11	9	6	3	2	1	7	8	4	-	12	10	5	-	-	Signal	A+	B+	0V	W+	U+	PE	Z+	Z-	V+	V-	A-	B-	+5V	W-	U-
PIN-A	1	2	3	4	5	6	7	8	9	10	11	12	13	14	15																																		
PIN-B	11	9	6	3	2	1	7	8	4	-	12	10	5	-	-																																		
Signal	A+	B+	0V	W+	U+	PE	Z+	Z-	V+	V-	A-	B-	+5V	W-	U-																																		

ELVM Series - 80mm



- Frame size: 80mm
- Power rating: 1000W
- Motor model: ELVM80100V48*H-***-HD

Cable Type	Diagram	Pin																																															
Motor power	 CABLE-RZD*M*-263	 <table border="1"> <tr><td>1</td><td>Red</td><td>U</td></tr> <tr><td>2</td><td>Blue</td><td>V</td></tr> <tr><td>3</td><td>Brown</td><td>W</td></tr> <tr><td>4</td><td>Yellow Green</td><td>PE</td></tr> </table>	1	Red	U	2	Blue	V	3	Brown	W	4	Yellow Green	PE																																			
1	Red	U																																															
2	Blue	V																																															
3	Brown	W																																															
4	Yellow Green	PE																																															
Motor brake	 CABLE-SCD*M*-113	 <table border="1"> <tr><td>1</td><td>Red</td><td>24V</td></tr> <tr><td>2</td><td>Black</td><td>0V</td></tr> </table>	1	Red	24V	2	Black	0V																																									
1	Red	24V																																															
2	Black	0V																																															
Motor encoder	Incremental CABLE-BMD*M*-213 (17Bit magnetic encoder)	 <table border="1"> <tr><td>A</td><td>Terminal</td><td>B</td></tr> <tr><td>1</td><td>PE</td><td>1</td></tr> <tr><td>2</td><td>5V</td><td>5</td></tr> <tr><td>3</td><td>0V</td><td>6</td></tr> <tr><td>4</td><td>SD+</td><td>7</td></tr> <tr><td>5</td><td>SD-</td><td>8</td></tr> <tr><td>6*</td><td>BAT+</td><td>-</td></tr> <tr><td>7*</td><td>BAT-</td><td>-</td></tr> </table>	A	Terminal	B	1	PE	1	2	5V	5	3	0V	6	4	SD+	7	5	SD-	8	6*	BAT+	-	7*	BAT-	-																							
	A	Terminal	B																																														
	1	PE	1																																														
2	5V	5																																															
3	0V	6																																															
4	SD+	7																																															
5	SD-	8																																															
6*	BAT+	-																																															
7*	BAT-	-																																															
Absolute CABLE-BMAD*M*-223 (17Bit magnetic encoder)	 <table border="1"> <tr><td>A</td><td>Terminal</td><td>B</td></tr> <tr><td>1</td><td>PE</td><td>1</td></tr> <tr><td>2</td><td>5V</td><td>5</td></tr> <tr><td>3</td><td>0V</td><td>6</td></tr> <tr><td>4</td><td>SD+</td><td>7</td></tr> <tr><td>5</td><td>SD-</td><td>8</td></tr> <tr><td>6*</td><td>BAT+</td><td>-</td></tr> <tr><td>7*</td><td>BAT-</td><td>-</td></tr> </table> <p>*Terminal 6 & 7 is to be connected to battery kit for absolute encoder</p>	A	Terminal	B	1	PE	1	2	5V	5	3	0V	6	4	SD+	7	5	SD-	8	6*	BAT+	-	7*	BAT-	-																								
A	Terminal	B																																															
1	PE	1																																															
2	5V	5																																															
3	0V	6																																															
4	SD+	7																																															
5	SD-	8																																															
6*	BAT+	-																																															
7*	BAT-	-																																															
 CABLE-LD2-BM*M* (2500 ppr encoder)	 <table border="1"> <tr><td>PIN-A</td><td>1</td><td>2</td><td>3</td><td>4</td><td>5</td><td>6</td><td>7</td><td>8</td><td>9</td><td>10</td><td>11</td><td>12</td><td>13</td><td>14</td><td>15</td></tr> <tr><td>PIN-B</td><td>11</td><td>9</td><td>6</td><td>3</td><td>2</td><td>1</td><td>7</td><td>8</td><td>4</td><td>-</td><td>12</td><td>10</td><td>5</td><td>-</td><td>-</td></tr> <tr><td>Signal</td><td>A+</td><td>B+</td><td>0V</td><td>W+</td><td>U+</td><td>PE</td><td>Z+</td><td>Z-</td><td>V+</td><td>V-</td><td>A-</td><td>B-</td><td>+5V</td><td>W-</td><td>U-</td></tr> </table>	PIN-A	1	2	3	4	5	6	7	8	9	10	11	12	13	14	15	PIN-B	11	9	6	3	2	1	7	8	4	-	12	10	5	-	-	Signal	A+	B+	0V	W+	U+	PE	Z+	Z-	V+	V-	A-	B-	+5V	W-	U-
PIN-A	1	2	3	4	5	6	7	8	9	10	11	12	13	14	15																																		
PIN-B	11	9	6	3	2	1	7	8	4	-	12	10	5	-	-																																		
Signal	A+	B+	0V	W+	U+	PE	Z+	Z-	V+	V-	A-	B-	+5V	W-	U-																																		

ELVM Series - 130mm



- Frame size: 130mm
- Power rating: 1200W-2000W
- Motor model: ELVM130**0V48*-***-HD

Cable Type	Diagram	Pin																																																												
Motor power	<p>CABLE-RZSD*M*-282</p>	<table border="1"> <tr><td>1</td><td>Red</td><td>U</td></tr> <tr><td>2</td><td>Blue</td><td>V</td></tr> <tr><td>3</td><td>Brown</td><td>W</td></tr> <tr><td>4</td><td>Yellow Green</td><td>PE</td></tr> <tr><td>5*</td><td>Black</td><td>0V</td></tr> <tr><td>6*</td><td>White</td><td>24V</td></tr> </table> <p>*5&6 terminal for motor with brake</p>	1	Red	U	2	Blue	V	3	Brown	W	4	Yellow Green	PE	5*	Black	0V	6*	White	24V																																										
		1	Red	U																																																										
2	Blue	V																																																												
3	Brown	W																																																												
4	Yellow Green	PE																																																												
5*	Black	0V																																																												
6*	White	24V																																																												
Motor encoder	<p>CABLE-BMD*M*-212 (17Bit magnetic encoder)</p>	<table border="1"> <tr><td>A</td><td>Terminal</td><td>B</td></tr> <tr><td>1</td><td>PE</td><td>1</td></tr> <tr><td>2</td><td>5V</td><td>5</td></tr> <tr><td>3</td><td>0V</td><td>6</td></tr> <tr><td>4</td><td>SD+</td><td>7</td></tr> <tr><td>5</td><td>SD-</td><td>8</td></tr> <tr><td>6*</td><td>BAT+</td><td>-</td></tr> <tr><td>7*</td><td>BAT-</td><td>-</td></tr> </table> <p>*Terminal 6 & 7 is to be connected to battery kit for absolute encoder</p>	A	Terminal	B	1	PE	1	2	5V	5	3	0V	6	4	SD+	7	5	SD-	8	6*	BAT+	-	7*	BAT-	-																																				
		A	Terminal	B																																																										
	1	PE	1																																																											
2	5V	5																																																												
3	0V	6																																																												
4	SD+	7																																																												
5	SD-	8																																																												
6*	BAT+	-																																																												
7*	BAT-	-																																																												
<p>CABLE-BMAD*M*-222 (17Bit magnetic encoder)</p>	<table border="1"> <tr><td>A</td><td>Terminal</td><td>B</td></tr> <tr><td>1</td><td>PE</td><td>1</td></tr> <tr><td>2</td><td>5V</td><td>5</td></tr> <tr><td>3</td><td>0V</td><td>6</td></tr> <tr><td>4</td><td>SD+</td><td>7</td></tr> <tr><td>5</td><td>SD-</td><td>8</td></tr> <tr><td>6*</td><td>BAT+</td><td>-</td></tr> <tr><td>7*</td><td>BAT-</td><td>-</td></tr> </table> <p>*Terminal 6 & 7 is to be connected to battery kit for absolute encoder</p>	A	Terminal	B	1	PE	1	2	5V	5	3	0V	6	4	SD+	7	5	SD-	8	6*	BAT+	-	7*	BAT-	-																																					
A	Terminal	B																																																												
1	PE	1																																																												
2	5V	5																																																												
3	0V	6																																																												
4	SD+	7																																																												
5	SD-	8																																																												
6*	BAT+	-																																																												
7*	BAT-	-																																																												
<p>CABLE-LD2-BM*M* (2500 ppr encoder)</p>	<table border="1"> <tr><td>10</td><td>11</td><td>12</td><td>13</td><td>14</td><td>15</td><td>11</td><td>12</td><td>13</td><td>14</td><td>15</td><td>12</td><td>11</td></tr> <tr><td>PIN-A</td><td>1</td><td>2</td><td>3</td><td>4</td><td>5</td><td>6</td><td>7</td><td>8</td><td>9</td><td>10</td><td>11</td><td>12</td><td>13</td><td>14</td><td>15</td></tr> <tr><td>PIN-B</td><td>11</td><td>9</td><td>6</td><td>3</td><td>2</td><td>1</td><td>7</td><td>8</td><td>4</td><td>-</td><td>12</td><td>10</td><td>5</td><td>-</td><td>-</td></tr> <tr><td>Signal</td><td>A+</td><td>B+</td><td>0V</td><td>W+</td><td>U+</td><td>PE</td><td>Z+</td><td>Z-</td><td>V+</td><td>V-</td><td>A-</td><td>B-</td><td>+5V</td><td>W-</td><td>U-</td></tr> </table>	10	11	12	13	14	15	11	12	13	14	15	12	11	PIN-A	1	2	3	4	5	6	7	8	9	10	11	12	13	14	15	PIN-B	11	9	6	3	2	1	7	8	4	-	12	10	5	-	-	Signal	A+	B+	0V	W+	U+	PE	Z+	Z-	V+	V-	A-	B-	+5V	W-	U-
10	11	12	13	14	15	11	12	13	14	15	12	11																																																		
PIN-A	1	2	3	4	5	6	7	8	9	10	11	12	13	14	15																																															
PIN-B	11	9	6	3	2	1	7	8	4	-	12	10	5	-	-																																															
Signal	A+	B+	0V	W+	U+	PE	Z+	Z-	V+	V-	A-	B-	+5V	W-	U-																																															

Typical configuration examples

ELVM-M17 Series

Type Name ELVM Series	Matched Drive		Matched Cable			
	CANopen	RS485	Motor Cable	Motor +Brake Cable	Encoder Cable	Brake Cable
4005V48EH-M17-HD	ELD2-CAN7005B	ELD2-RS7005	/	CABLE-RZSD*M*-123	CABLE-BMAD*M*-223 (Multi-turn)	/
4005V48FH-M17-HD			CABLE-RZD*M*-123	/		
4010V48EH-M17-HD			/	CABLE-RZSD*M*-123		
4010V48FH-M17-HD			CABLE-RZD*M*-123	/		
6020V24EH-M17-HD	ELD2-CAN7010B	ELD2-RS7010	CABLE-RZD*M*-143	/	CABLE-BMAD*M*-223 (Multi-turn)	CABLE-SCD*M*-113
6020V24FH-M17-HD			/	/		/
6020V48EH-M17-HD			CABLE-RZD*M*-123	/		CABLE-SCD*M*-113
6020V48FH-M17-HD			/	/		/
6040V24EH-M17-HD	ELD2-CAN7020B	ELD2-RS7020B	CABLE-RZD*M*-253	/	---	CABLE-SCD*M*-113
6040V24FH-M17-HD	2ELD2-CAN7020B	2ELD2-RS7020B	/	/	/	/
6040V48EH-M17-HD	ELD2-CAN7010B	ELD2-RS7010	CABLE-RZD*M*-143	/	CABLE-BMD*M*-213 (Single-turn)	CABLE-SCD*M*-113
6040V48FH-M17-HD			/	/		/
6060V48EH-M17-HD	ELD2-CAN7015B	ELD2-RS7015B	/	/	CABLE-BMD*M*-213 (Single-turn)	CABLE-SCD*M*-113
6060V48FH-M17-HD			CABLE-RZD*M*-253	/		/
8075V48EH-M17-HD	ELD2-CAN7020B	ELD2-RS7020B	/	/	CABLE-BMD*M*-213 (Single-turn)	CABLE-SCD*M*-113
8075V48FH-M17-HD	2ELD2-CAN7020B	2ELD2-RS7020B	/	/		/
80100V48EH-M17-HD	ELD2-CAN7030B	ELD2-RS7030B	CABLE-RZD*M*-263	/	CABLE-BMD*M*-213 (Single-turn)	CABLE-SCD*M*-113
80100V48FH-M17-HD	2ELD2-CAN7030B	2ELD2-RS7030B	/	/		/
130120V48EM-M17-HD	ELD2-CAN7040B	ELD2-RS7040B	CABLE-RZSD*M*-282	/	CABLE-BMAD*M*-222 (Multi-turn)	/
130120V48FM-M17-HD						
130150V48EM-M17-HD						
130150V48FM-M17-HD						
130200V48EM-M17-HD	ELD2-CAN7060B	ELD2-RS7060B	/	/	CABLE-BMD*M*-212 (Single-turn)	/
130200V48FM-M17-HD						

ELVM-B25 Series

Type Name ELVM Series	Matched Drive		Matched Cable			
	CANopen	RS485	Motor Cable	Motor +Brake Cable	Encoder Cable	Brake Cable
4005V48EH-B25-HD	ELD2-CAN7005B	ELD2-RS7005	/	CABLE-RZSD*M*-123		/
4005V48FH-B25-HD			CABLE-RZD*M*-123	/		
4010V48EH-B25-HD			/	CABLE-RZSD*M*-123		
4010V48FH-B25-HD			CABLE-RZD*M*-123	/		
6020V24EH-B25-HD	ELD2-CAN7010B	ELD2-RS7010	CABLE-RZD*M*-143	/	CABLE-LD2-BM*M* (Single-turn)	CABLE-SCD*M*-113
6020V24FH-B25-HD			/	/		
6020V48EH-B25-HD			CABLE-RZD*M*-123	/		CABLE-SCD*M*-113
6020V48FH-B25-HD			/	/		
6040V24EH-B25-HD	ELD2-CAN7020B	ELD2-RS7020B	CABLE-RZD*M*-253	/	CABLE-LD2-BM*M* (Single-turn)	CABLE-SCD*M*-113
6040V24FH-B25-HD	2ELD2-CAN7020B	2ELD2-RS7020B	/	/		/
6040V48EH-B25-HD	ELD2-CAN7010B	ELD2-RS7010	CABLE-RZD*M*-143	/		CABLE-SCD*M*-113
6040V48FH-B25-HD			/	/		
6060V48EH-B25-HD	ELD2-CAN7015B	ELD2-RS7015B	CABLE-RZD*M*-253	/		CABLE-SCD*M*-113
6060V48FH-B25-HD				/		/
8075V48EH-B25-HD	ELD2-CAN7020B	ELD2-RS7020B	/	/		CABLE-SCD*M*-113
8075V48FH-B25-HD	2ELD2-CAN7020B	2ELD2-RS7020B	/	/		/
80100V48EH-B25-HD	ELD2-CAN7030B	ELD2-RS7030B	CABLE-RZD*M*-263	/		CABLE-SCD*M*-113
80100V48FH-B25-HD	2ELD2-CAN7030B	2ELD2-RS7030B	/	/		/

Leadshine Motion Control Total Product System

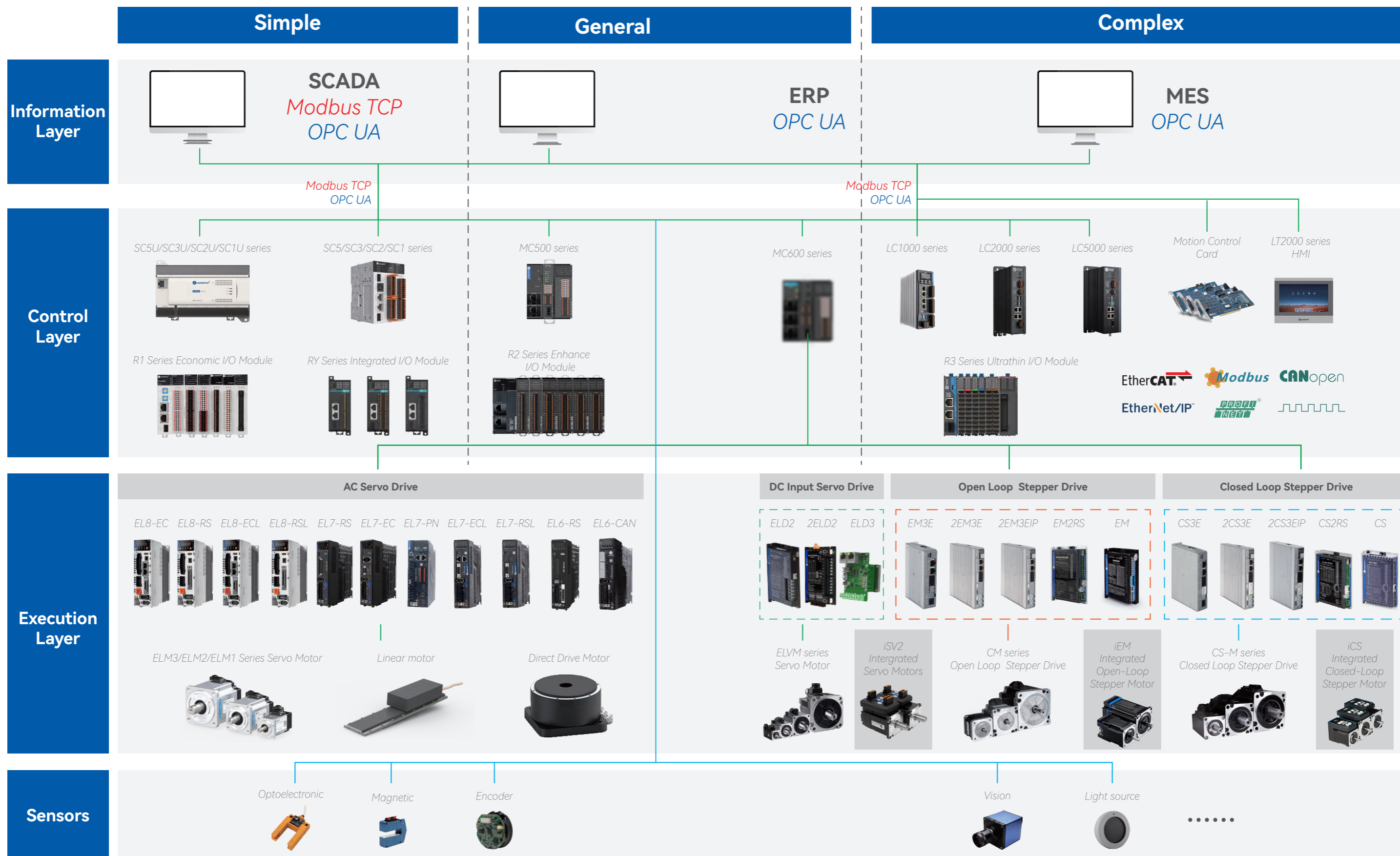

Leadshine Servo Product

DC Servo Drive Series

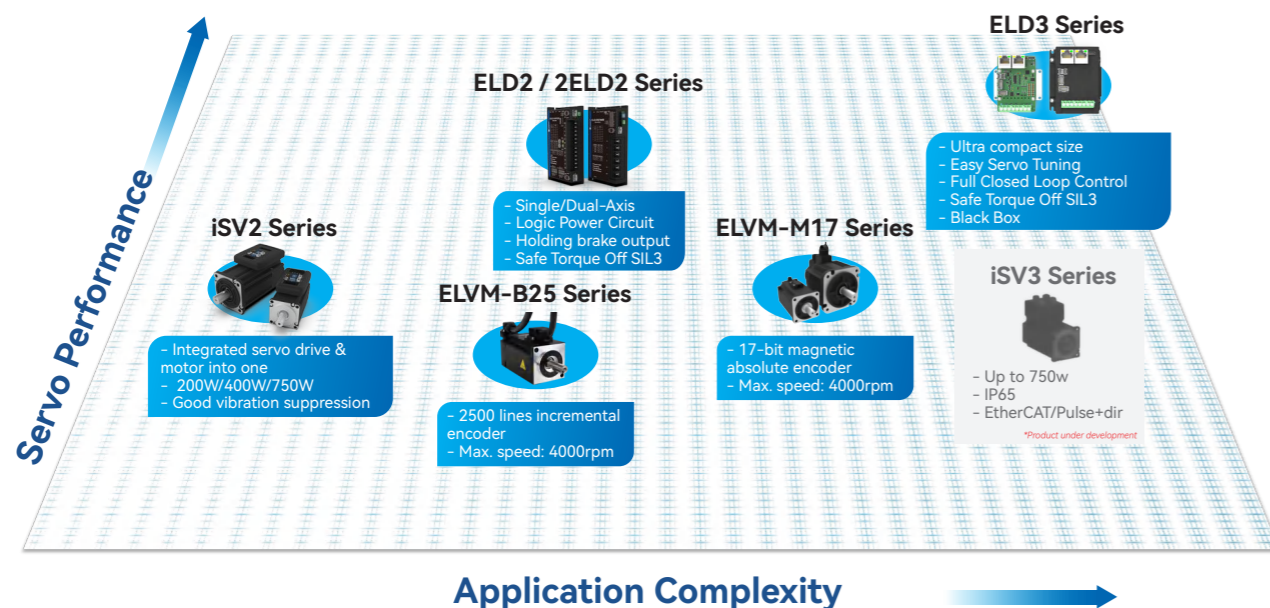

Simple Introduction

ELD3 Series

Latest full functional ultra-compact sized DC Servo Drives with EtherCAT control (Modbus RTU, Pulse + Direction, Analogue, CANopen version coming soon). Equipped with more user friendly servo features. Currently, offering 4 models from 50W to 750W. Available with and without housing.

ELD2/2ELD2 Series

Single and Dual-axis series DC servo drives with Modbus RTU, Pulse + Direction, Analogue and CANopen control. Delivers great performance for most applications requiring smooth and economical solutions. Power rating ranging from 200W up to 2000W.

iSV2 Series

Integrated servo motor with drive and motor combined into one unit to save installation space and wiring work. This series delivers overloading capability up to 3 times and gives good positioning with 17-bit magnetic encoder.

ELVM Series

ELVM Series servo motors come with 17-bit magnetic absolute encoder and 2500ppr incremental encoder. The servo motors are also equipped with SP21 connectors which make the connections stable and the motor IP65 rated. Power rating ranging from 33W to 2600mm with flange size of 25/40/60/80/130mm.

Applications



Logistic Sorting Line

- Integrated Servo Motor combines drive and motor in one, saving 50% installation and make wiring work easier.
- Supports DC input of 24-70V. Switching power supply easily available.
- 3 times overload capacity with motor power rating up to 750W for heavier loaded applications.
- High servo responsiveness with smooth acceleration and deceleration.
- Smooth motion with vibration suppression.

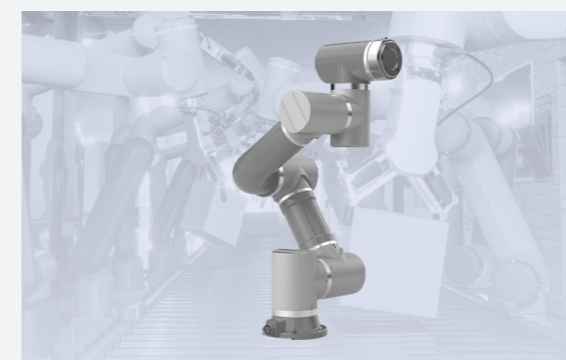

Collaborative Robots (COBOTS)

- Compact sized full functional servo drive.
- Safety features: Low EMC, Safe Torque Off SIL3, Logic Power Circuit.
- Lightweight and small dimension drive suitable for smaller robots.
- Full closed loop control for better positioning control.



AGV / RGV

- Dual-axis DC servo drive with input of 24-70VDC.
- ELD2 series Servo Drive supports standard CANopen and Modbus RTU protocol.
- Can be powered using batteries.
- Positioning accuracy of mobile vehicles up to +-1mm.
- With good overloading capacity and high response, velocity of the vehicles can reach up to 5m/s and acceleration of 2m/s².

Leadshine Servo Products Quick Selection

Servo Drive	Model	Power (W)	Main Voltage (VDC)	Logic Power (VDC)	Dimensions (mm)	Weight (kg)	Command Source		Command Source			STO	Encoder Output	Brake Output	Digital Inputs	Digital Outputs	Analog Inputs	Matched Servo Motors			
							Pulse+Dir	Analog	RS485	EtherCAT	CANopen										
DC Servo Drive Single-Axis ELD2 Series	ELD2-RS7005	200	24-70	-	118*75.5*25.5	0.2	√	√	√						4	2	*ELVM Servo Motors for more information please refer to pages 50 to 51				
	ELD2-CAN7005B				140*79.5*25.5	0.3					√		√		4	2					
	ELD2-RS7010	400			118*75.5*25.5	0.2	√	√	√			√		4	2						
	ELD2-CAN7010B				140*79.5*25.5	0.3					√	√	√	4	2						
	ELD2-RS7015B	600			175*100.5*31	0.7	√	√	√			√	√	4	2						
	ELD2-CAN7015B									√	√	√	4	2							
	ELD2-RS7020B	750					√	√	√			√	√	√	4	2					
	ELD2-CAN7020B									√	√	√	4	2							
	ELD2-RS7030B	1200					√	√	√			√	√	√	4	2					
	ELD2-CAN7030B									√	√	√	4	2							
	ELD2-RS7040B	1500					√	√	√			√	√	√	4	2					
	ELD2-CAN7040B									√	√	√	4	2							
	ELD2-RS7060B	2500					24-70	194*103*41	0.9	√	√	√		√	√	√		4	2		
	ELD2-CAN7060B												√	√	√	4		2			
DC Servo Drive Dual-Axis 2ELD2 Series	2ELD2-RS7020B	750*2	24-70	24-70						194*103*41	1.0	√		√		√		√	4*2	2*2	*3rd Party Brushless / Brushed Motor
	2ELD2-CAN7020B												√		√		√	4*2	2*2		
	2ELD2-RS7030B	1200*2										√		√		√	4*2	2*2			
	2ELD2-CAN7030B												√		√	4*2	2*2				
DC Servo Drive Mini ELD3 Series	ELD3-EC7001B	50	24-70	24-30	73*66*37	0.15							√		√	√	√	6	3	2	
	ELD3-EC7005B	200											√		√	√	√	6	3	2	
	ELD3-EC7010B	400											√		√	√	√	6	3	2	
	ELD3-EC7020B	750											√		√	√	√	6	3	2	

Integrated Servo Motor	Model	Power (W)	Input Voltage (VDC)	Flange size (mm)	Current (Arms)		Torque (Nm)		Rotational speed (rpm)		Command Source			STO	Digital Inputs	Digital Outputs
					Rated	Peak	Rated	Peak	Rated	Peak	Pulse+Dir	Analog	RS485			
iSV2 Integrated Series	iSV2-CAN6020V24	200	24-60	60	11	34	0.64	1.92	3000	4000				√	4	2
	iSV2-RS6020V24										√	√		4+2	2	
	iSV2-CAN6020V48							√			4+2	2				
	iSV2-RS6020V48				√	√		4+2			2					
	iSV2-CAN6040V48	400		10	28	1.27	3.81						√	4	2	
	iSV2-RS6040V48							√			√		4+2	2		
	iSV2-CAN8075V48	750		19	57	2.4	7.2						√	4	2	
	iSV2-RS8075V48							√			√		4+2	2		
	iSV2-RS5740V48H	400		10	28	1.27	3.81	√			√		4+2	2		
	iSV2-RS8675V48H	750		19	57	2.4	7.2	√			√		4+2	2		



● Headquarters in Shenzhen



● Shanghai Intelligent Industry Park



● Production base in Shenzhen

- **Founded in 1997**
- **Public Listed Company in China (002979.SZ)**
- **Dedication in Motion Control**
Stepper/Servo systems, Motion Controllers, PLC
Control systems, I/O Modules, Encoders
- **A leading supplier of motion control products and solutions in the world**
- **Customer Oriented, Technology Oriented, Forever Improving, Sharing of Success**

25+ Experience 400+ R&D Engineers 5 Subsidiaries 60+ Countries Clients 10000+ Global Partners 30million+ Installed Axes



Headquarters China Leadshine Technology Co., Ltd.

+86 755 26411692 +86 755 26402718
www.leadshine.com
sales@leadshine.com (Sales)
tech@leadshine.com (Technical Support)
15-20/F, Block B, Nanshan i-Valley, Shuguang Community,
Xili Town, Nanshan District, Shenzhen 518055, China

North America Office Leadshine America, Inc.

1-949-608-7270 1-949-638-7298
www.leadshineusa.com
sales@leadshineusa.com (Sales)
support@leadshineusa.com (Technical Support)
26050 Towne Centre Dr.Foothill Ranch, CA 92610 USA



@Leadshine