

Large-Capacity Controller **X-SEL** P/Q/QX

The New
X-SEL
P/Q/QX!

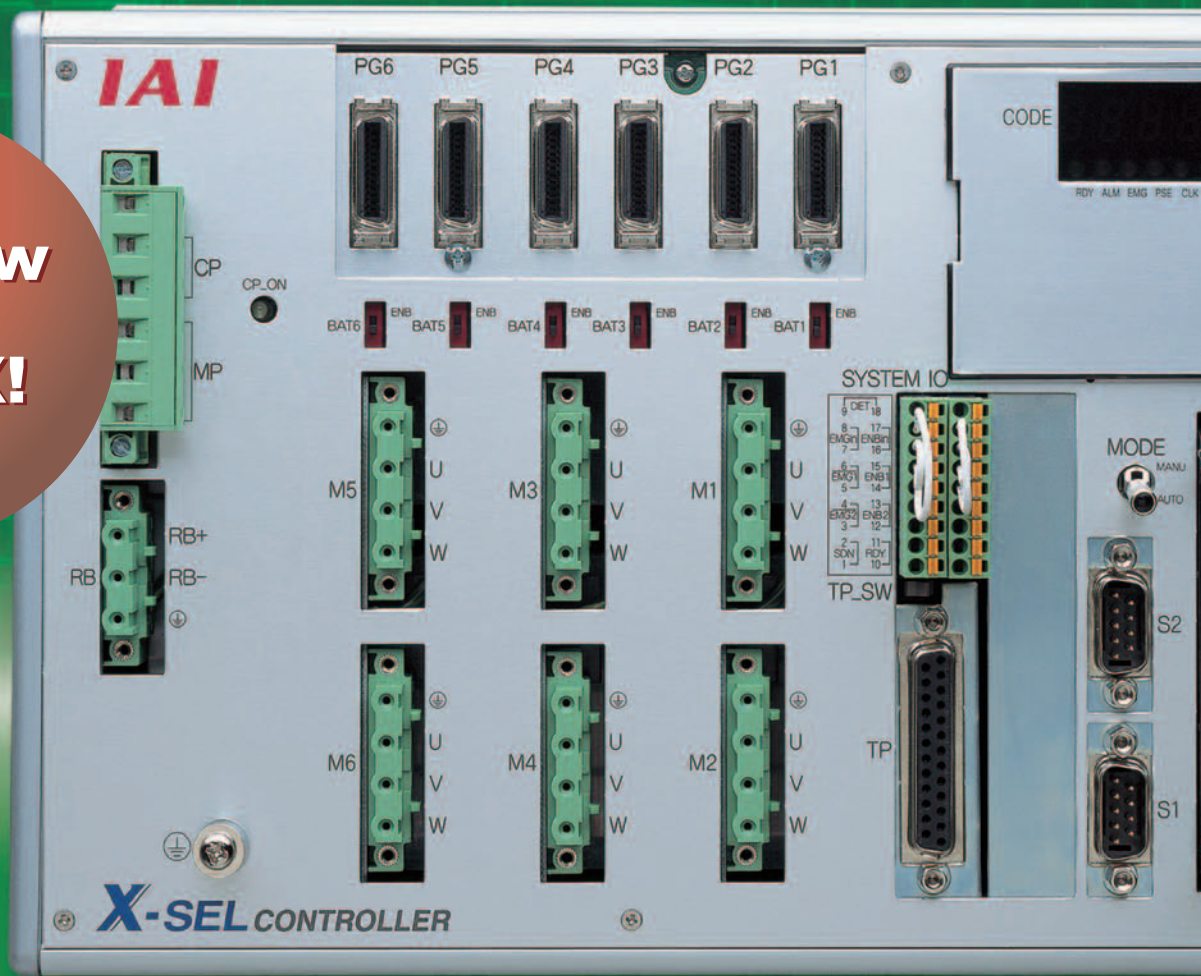

1 Maximum output of 2400 W

Six 400 W single-axis robots or three 750 W single-axis robots can be operated simultaneously.



2 Capable of driving one to six axes

A maximum of six axes can be operated complementarily using only one controller unit. Six axes are operated with a single program allowing easy programming.

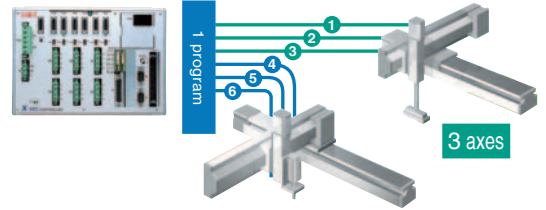

3 Controlling SCARA robots (4 axes) plus 2 additional axes

The X-SEL-QX can control SCARA robots plus up to two axes in a combination of single-axis and/or cartesian robots (total wattage: 2400 W) (*1). If the SCARA robot has an arm length of 500/600, two 750 W axes can be operated together.

(*1) Single-axis robots may not be connectable depending on the type of SCARA robot. For details, refer to the notes under "Models."

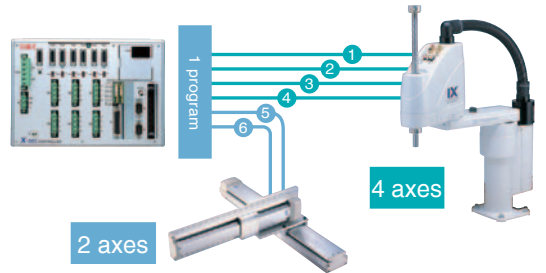

4 "Global type" for applications that require conformance to safety category 4

The "global type" does not have a built-in drive-source cutoff circuit. Instead, it cuts off the drive source using an external safety circuit. This design conforms to safety category 4 under ISO 13849-1. The large-capacity global types Q and QX conform to the ANSI and CE Mark standard.

5 Conveyor tracking function (Optional)

The QX can be configured to detect works on the conveyor using a vision system and handle them synchronously with the conveyor movement. The conveyor tracking function will surely improve the work efficiency of your equipment.

(Note) The conveyor tracking function is effective only if the actuator has an arm length of 500/600. Also, this function may not be supported under certain operating conditions. If you are considering adding the conveyor tracking option, consult IAI's Sales Department.

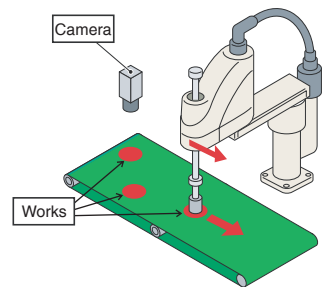

6 Compact, high performance and CE-compliant

- Approx. 40% slimmer than IAI's conventional controllers X-SEL-KE/KET/KETX.
- Significantly faster than IAI's conventional controllers (the command processing time is around half).
- Connectable to DeviceNet, CC-Link, Ethernet, Profibus and other networks.
- Conforming to the CE Mark standard.

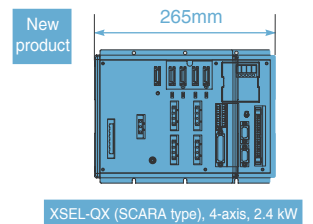
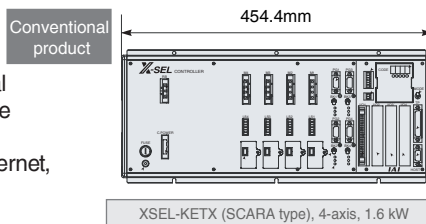

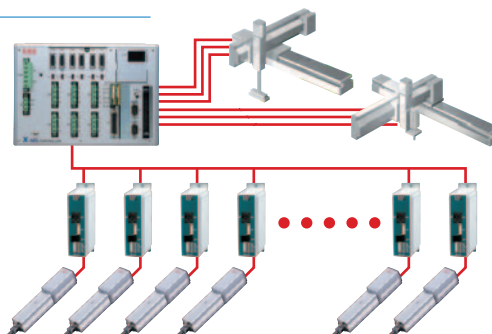

7 ROBO Cylinder Gateway Function

- Up to 16 ROBO Cylinder axes can be additionally operated via serial communication using the gateway function.
- ROBO Cylinders can be operated using SEL language programs. You can also change the position data of your ROBO Cylinder or read the current ROBO Cylinder position.



X-SEL Series Product Lineup

	XSEL-KE	XSEL-KET	XSEL-KETX	XSEL-P	XSEL-Q	XSEL-QX
	Standard Actuator Type	Global Actuator Type (Safety Category 4)	Global SCARA Type (Safety Category 4)	Large-capacity Standard Actuator Type	Large-cap. Global Actuator Type (Safety Category 4)	Large-cap. Global SCARA Type (Safety Category 4)
						
Operating method	Program operation			Program operation		
Programs	64 programs (6000 steps)			128 programs (9999 steps)		
Number of positions	3000 positions			20000 positions		
Maximum number of connectable axes	4 axes			6 axes		
Maximum output	1.6 kW			1.6 kW / 2.4 kW		
Power supply	Single-phase 100VAC / Single-phase 230VAC			Single-phase 230VAC / Three-phase 230VAC		
Safety category	B	Corresponds to Category 4	Corresponds to Category 4	B	Corresponds to Category 4	Corresponds to Category 4
Safety standard	CE	CE, ANSI (*1)	CE, ANSI (*1)	CE	CE, ANSI (*1)	CE, ANSI (*1)

*1 To support ANSI, the ANSI-compatible teaching pendant (SEL-TD or IA-T-XA) is required.

Larger Program Data Capacity of new X-SEL-P/Q/QX Generation

The program data capacity of the XSEL controller has increased as follows:

		Current Model	Enhancement Specifications
		P/Q/QX	P/Q/QX
Programs	Number of Programs	64	128
	Number of Program Steps	6000	9999
Position Data	Number of Positions (Positions that can be backed up by the battery)	4000 (4000)	20000 (10000)
	Number of Error Records	100	200
ROBO Cylinder Gateway Function		None	Standard Feature

- The enhanced XSEL controllers are available only with controller firmware (main CPU application) of version 0.68 or later (P/Q types) or version 0.34 or later (QX types).
- The enhanced XSEL controllers only support PC software (IA-101-X-MW) of version 7.2.0.0 or later.
- The enhanced XSEL controllers only support IA-T-X (XD) teaching pendants version 1.4.4 or later and SEL-T (TD) teaching pendants of version 1.0.1 or later.

New ROBO Cylinder Gateway Function

The ROBO Cylinder gateway function controls ROBO Cylinders from an XSEL controller via serial communication. Use of the gateway function significantly reduces the hassle of wiring compared to the PIO control method, and you can also operate ROBO Cylinders using SEL language programs from your XSEL controller.

Specifications

Item	Description
Maximum number of connectable ROBO Cylinder axes	16
Maximum number of axes operable by XSEL controller	6
Supported ROBO Cylinder series	ERC2/RCP2/RCP3/RCA/RCA2/RCS2
Connectable controllers	ERC2/PCON/ACON/SCON/ROBONET
Communication protocol	Modbus

Examples of Use (Example of replacing a PIO-controlled system with a gateway system)

Operate a SCARA robot chuck consisting of a ROBO Gripper using the gateway function.

While the PIO-controlled system had to measure loads in the previous process and sort them based on their size to transfer accordingly, the gateway system allows length measurement to be performed by the ROBO Gripper. As a result, the process has become shorter.

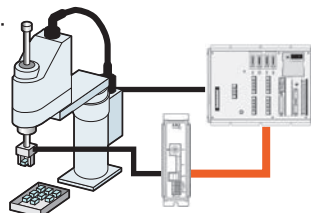

<Comparison of PIO Control and Gateway Function>

	PIO Control	Gateway Function
Hassle of Wiring	Many cables must be wired	Only two cables need to be wired
Control Method	ON/OFF control of I/Os only	Programs can be used
Moving Positions	Positions must be input to the controller before hand	Positions can be instructed from an XSEL controller
Current chuck position	Checked by the completed position number	The current position can be checked numerically

Connected Units

The following units are needed to use the ROBO Cylinder gateway function. (Contact IAI for the wiring method and other details)

Name	Model	Remarks
RS232 conversion unit	RCB-CV-GW	One RS232 conversion unit is required for one XSEL controller
Communication cable	CB-RCB-SI0050	One communication cable is required for one XSEL controller
Controller link cable	CB-RCB-CTL002	The number of controller link cables must be the same as the number of ROBO Cylinder controllers connected

ACTUATOR MODELS	XSEL - P - 3 - 400AL - 200AL - 60ABL - PR - P1 - EEE - 2 - 2
SCARA MODELS	XSEL - QX6 - NNN5020 - 750AL - 750ABL - PR - P1 - EEE - 2 - 3

① Series	② Controller type	③ Number of axes or IX robot model	④ Motor output of first actuator axis	⑤ Motor output of next actuator axis	⑥ Dedicated network slot	⑦ Standard I/O				⑧ Expansion I/O				⑨ I/O flat cable length	⑩ Power-supply voltage								
						Slot 1	Slot 2	Slot 3	Slot 4	Slot 2	Slot 3	Slot 4											
XSEL	P4 (standard actuator 4-axis type)	1 (1 axis)	Blank (No single axis)	Blank (No single axis)	Blank (No network) DV (DeviceNet) CC (CC-Link) PR (ProfiBus) ET (Ethernet)	E (Not used)	E (Not used)	E (Not used)	E (Not used)	2 (Standard specification: 2m)	2 Single-phase 230V	2 Single-phase 230V	2 Single-phase 230V	2 Single-phase 230V									
	P5 (standard actuator 5-axis type)	2 (2 axes)	20□ (20W)	20□ (20W)											N1 I/O board NPN32/16	N1 I/O board NPN32/16	N1 I/O board NPN32/16	N1 I/O board NPN32/16	3 (3m)	3 Three-phase 230V	3 Three-phase 230V	3 Three-phase 230V	
	P6 (standard actuator 6-axis type)	3 (3 axes)	30□ (30W)	30□ (30W)											N2 I/O board NPN16/32	N2 I/O board NPN16/32	N2 I/O board NPN16/32	N2 I/O board NPN16/32	5 (5m)	5 Three-phase 230V	5 Three-phase 230V	5 Three-phase 230V	
	Q4 (global actuator 4-axis type)	4 (4 axes)	60□ (60W)	60□ (60W)											P1 I/O board PNP32/16	P1 I/O board PNP32/16	P1 I/O board PNP32/16	P1 I/O board PNP32/16	0 (None)	0 (None)	0 (None)	0 (None)	
	Q5 (global actuator 5-axis type)	5 (5 axes)	100□ (100W)	100□ (100W)											P2 I/O board PNP16/32	P2 I/O board PNP16/32	P2 I/O board PNP16/32	P2 I/O board PNP16/32					
	Q6 (global actuator 6-axis type)	6 (6 axes)	NNN1205~8040 (Standard type)	200□ (200W)											200□ (200W)								
	QX4 (global SCARA 4-axis type)	4 (4 axes)	NSN5016~6016 (High-speed type)	400□ (400W)											400□ (400W)								
	QX5 (global SCARA 5-axis type)	5 (5 axes)	NNW2515~8040 (Dustproof/splash-proof type)	600□L (600W)											600□L (600W)								
	QX6 (global SCARA 6-axis type)	6 (6 axes)	T/UNN3015~3515 (Wall mount type)	750□L (750W)											750□L (750W)								
			H/INN5020~8040 (Ceiling mount type)																				
		NNC1205~8040 (Cleanroom type)																					

① Series

Indicate the series name.

② Controller type

Indicate the controller type.

- P1-6 Large-capacity, 1-6-axis ACTUATOR specification
- Q1-6 Large-capacity, 1-6-axis ACTUATOR specification conforming to safety category 4 (global version)
- QX4 Large-capacity, dedicated SCARA specification conforming to safety category 4 (global version)
- QX5 Large-capacity, 5-axis (SCARA + 1 axis) specification conforming to safety category 4 (global version)
- QX6 Large-capacity, 6-axis (SCARA + 2 axes) specification conforming to safety category 4 (global version)

③ Number of axes or IX robot model

Indicate the actuator axes or the SCARA type to be operated.

Notes

- * If the SCARA robot has an arm length of 700/800, the QX connects up to 5 axes (SCARA + 1 axis).
- * The high-speed type connects up to 4 axes (SCARA only).

④ Motor output of axis 1 or 5 (single-axis robot)

Indicate the motor output of axis 1 of a multi/single-axis robot or of the single-axis robot connected as axis 5 of the QX5/QX6. In □, enter codes corresponding to the encoder type and desired option(s).

* If you are selecting multiple options, enter the corresponding codes in alphabetical order after the encoder type code.

If you are ordering your controller without options, enter only the encoder type code.

- (Encoder type A: Absolute / I: Incremental)
 - (Options B: Brake / C: Creep sensor)
 - L: Limit switch
 - M: Master-axis designation in synchronized operation
 - S: Slave-axis designation in synchronized operation)
- Leave the space blank for the QX4.

⑤ Motor output of other or axis 6 (single-axis robot)

Indicate the motor output of axis 2-6 of multi- or other single-axis robot or of the single-axis robot connected as axis 6 of the QX6. The content of □ conforms to the same explanation for axis 5. Leave the space blank for the QX4.

⑥ Dedicated network slot

Indicate an applicable network if you want to connect the P/Q/QX to DeviceNet, CC-Link, ProfiBus or Ethernet

⑦ Standard I/O (Slot 1)

Indicate the specification of the standard slot (slot 1).

⑧ Expansion I/O (Slots 2 to 4)

Indicate the specification of the expansion slots (slots 2 to 4). Take note that use of expansion slots will change the external dimensions.

⑨ I/O flat cable length

Indicate the length of the signal wire connecting each I/O board and the PLC.

* If you have selected "E (Not used)" for the standard and expansion I/Os, "0 (None)" will be selected automatically.

⑩ Power-supply voltage

Indicate the voltage of the main controller power supply.

Specifications

	Large-capacity Actuator type		Large-capacity Scara type	
	P4 / Q4	P5 / P6 / Q5 / Q6	QX4	QX5 / QX6
Total output when maximum number of axes are connected	2400 W (three-phase 230 VAC) / 1600 W (single-phase 230 VAC)			
Control power input	Single-phase 200/230VAC (-15%, +10%)			
Motor power input	2.4 kW type: three-phase 230VAC (-10%, +10%) / 1.6 kW type: Single-phase 230VAC (-15%, +10%)			
Max. Power capacity (*5)	4878 VA (600 W x 4 axes)	4998 VA (400 W x 4 axes)	3625 VA (*1)	5005 VA (*2)
Safety circuit configuration	Redundant configuration not supported		Redundant configuration supported	
Drive-power cutoff method	P type: Internal cutoff relay Q type: External safety circuit		External safety circuit	
Enable input	P type: Contact-B input (internal power supply type) (Q type: redundant)		(external power supply type, redundant)	
Position detection method	Incremental encoder / absolute encoder			
Speed setting (*3)	1mm/sec~2000mm/sec			
Acceleration/deceleration setting (*3)	0.01G~1G			
Programming language	Super SEL Language			
Number of program steps	9999 steps (total)			
Number of positions	20000 positions (total); 10000 positions can be backed up by the battery)			
Number of programs	128 programs			
Operating temperature/humidity	0~40°C, 10~95% (non-condensing)			
Weight (*4)	P type: 5.2 kg Q type: 4.5 kg	P type: 5.7 kg Q type: 5.0 kg	4.5 kg	5.0 kg

*1 When a SCARA robot of 700/800 arm length is operated.

*2 When a SCARA robot of 500/600 arm length and two 750-W axes are operated.

*3 The maximum limit varies depending on the actuator type.

*4 The controller weight includes the absolute battery, brake mechanism and expansion I/O box.

*5 Based on the maximum wattage of each connected axis.

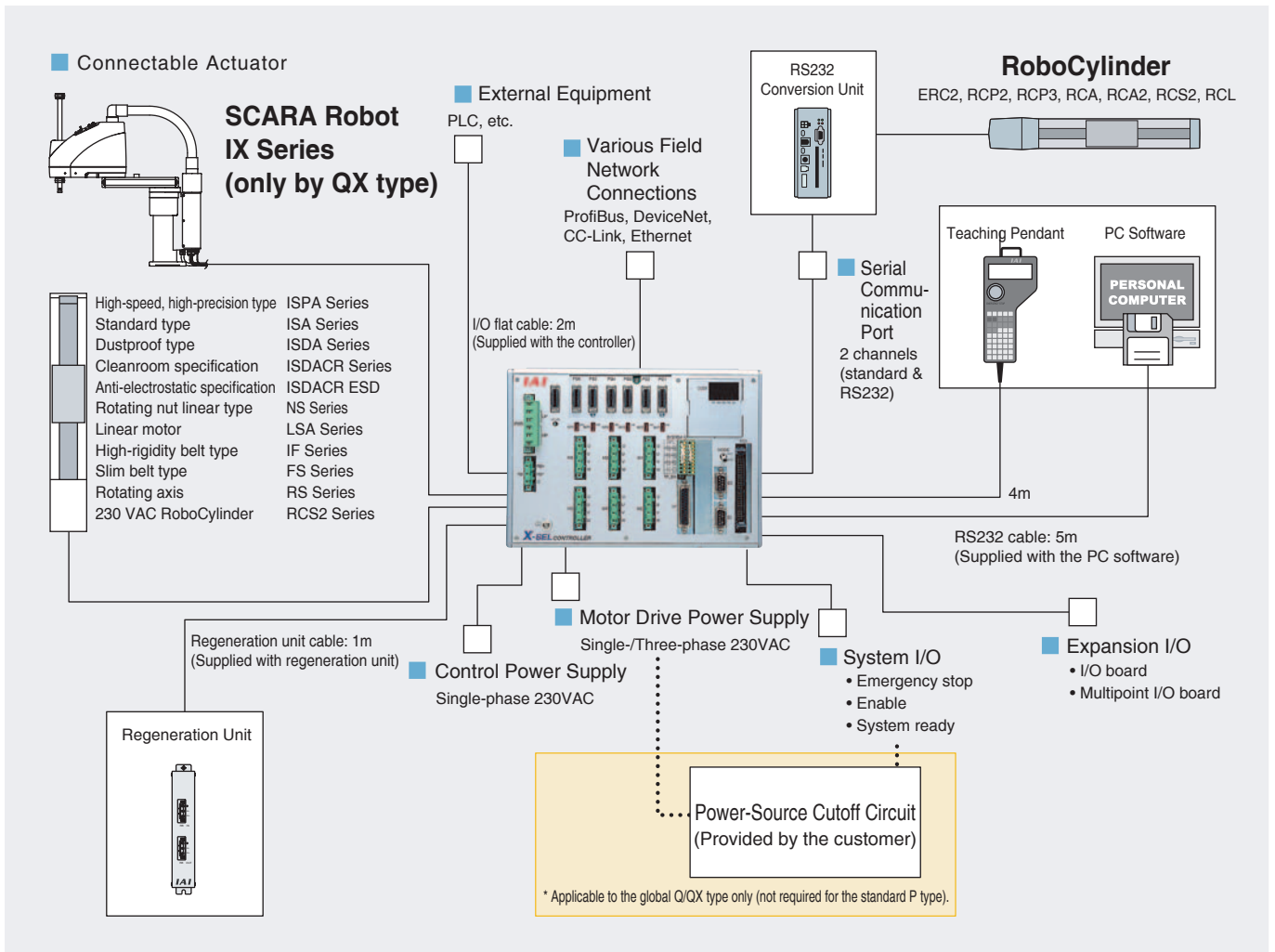

Options

Teaching Pendant

Model : SEL-T (Standard)

SEL-TD (With deadman switch)

IA-T-XA (ANSI/CE Mark compliant type)

This teaching device supports program/position input, test operation, monitoring, etc.

* SEL-T/TD of version 1.0.0 or older and IA-T-XA of version 1.4.3 or older cannot be used with the P/Q/QX controllers.



PC Software

Model : IA-101-X/XA-CW (XA: Q/QX type)

With a PC link cable (equipped with a D-sub, 9-pin connector on the PC end)

IA-101-X-USBMW

With USB adapter cable

This software is a startup support tool offering the functions needed to input programs/positions and perform debugging.

* Program versions older than 7.2.0 cannot be used with the enhanced P/Q/QX controllers.

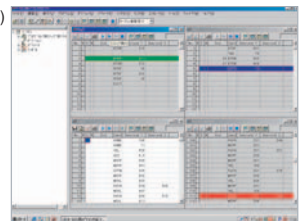

Regeneration Unit

Model : REU-1

This unit converts to heat the regenerative current produced when the motor decelerates.

The regeneration unit may be required depending on the total motor output of single-axis robots connected to the controller (SCARA robots do not require this unit).

Refer to the table shown to the right for a guideline on whether or not the regeneration unit is required and if so, how many.

Motor output	Horizontal application	Vertical application
0 ~ 100W	Not required	Not required
~ 200W	Not required	1 unit
~ 400W	1 unit	1 unit
~ 600W	1 unit	1 unit
~ 800W	1 unit	1 unit
~ 1000W	1 unit	2 units
~ 1200W	2 units	2 units
~ 1500W	2 units	3 units

External Dimensions

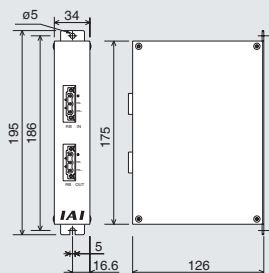

External Dimensions

The external dimensions of X-SEL-P/Q/QX controllers vary depending on the number of connected axes, the type (arm length) of connected SCARA robot, use/non-use of expansion I/O, and types of direct-coupled axes. In the table below, select the controller specification meeting your specific requirements and refer to the drawing of the corresponding number.

		X-SEL-P 1.6/2.4 kW type, X-SEL-Q/QX 1.6 kW type		X-SEL-Q/QX 2.4 kW type		Side view (common)
		1-4 axes (P/Q-1/2/3/4) or SCARA only (QX4)	5-6 axes (P/Q-5/6) or SCARA + direct-coupled axes (QX5/6)	1-4 axes (Q-1/2/3/4) or SCARA only (QX4)	5-6 axes (Q-5/6) or SCARA + direct-coupled axes (QX5/6)	
Without expansion I/O	External dimensions ①					<p>* All controller types have the same height</p>
	External dimensions ②					
With expansion I/O	External dimensions ③					
	External dimensions ④					

ACTUATOR CONTROLLER SPECIFICATIONS In the case of the following specifications, the overall width will follow the table (mounting hole positions are the same).	P type (1-/3-ph.), 1.6 kW Q type (1-ph.)		2.4 kW Q type (3-ph.)	
	Axis 1 to axis 4	Axis 5 to axis 6	Axis 1 to axis 4	Axis 5 to axis 6
With absolute battery/brake unit *1	285 ②	340 ⑥	242 ⑩	297 ⑭
With I/O expansion base *2	338 ③	373 ⑦	295 ⑪	330 ⑮
With I/O expansion base + absolute battery/brake unit *3	358 ④	413 ⑧	315 ⑫	370 ⑯

*1 With absolute battery or brake, or absolute battery with brake.
 *2 When expansion I/Os are added.
 *3 With absolute battery or brake, or absolute battery with brake, plus expansion I/Os.

SCARA		Controller							
Type	Arm length	1.6 kW QX type (1-phasis)				2.4 kW QX type (3-phasis)			
		SCARA only (QX4)		SCARA + direct-coupled axes(QX5/QX6)		SCARA only (QX4)		SCARA + direct-coupled axis(es)(QX5/QX6)	
		Without expansion I/O	With expansion I/O	Without expansion I/O	With expansion I/O	Without expansion I/O	With expansion I/O	Without expansion I/O	With expansion I/O
Standard type Cleanroom type Wall mount type Ceiling mount type	120	External dimensions ①	External dimensions ③	External dimensions ⑤ ^(*)	External dimensions ⑦ ^(*)	External dimensions ⑨	External dimensions ⑪	External dimensions ⑬ ^(*)	External dimensions ⑮ ^(*)
	150								
	180								
	250								
	350	External dimensions ②	External dimensions ④	External dimensions ⑥	External dimensions ⑧	External dimensions ⑩	External dimensions ⑫	External dimensions ⑭	External dimensions ⑯
	500								
High-speed type	600								
	700								
	800	External dimensions ⑥ ^(*)	External dimensions ⑧ ^(*)	-	-	External dimensions ⑭ ^(*)	External dimensions ⑯ ^(*)	-	-
	500								
	600								

(*)1 If the direct-coupled axis has a brake or is of absolute encoder specification, refer to external dimensions ⑥.
 (*)2 If the direct-coupled axis has a brake or is of absolute encoder specification, refer to external dimensions ⑧.
 (*)3 If the direct-coupled axis has a brake or is of absolute encoder specification, refer to external dimensions ⑩.
 (*)4 If the direct-coupled axis has a brake or is of absolute encoder specification, refer to external dimensions ⑮.
 (*)5 Due to the large motor wattage of the SCARA robot, the external dimensions of a 6-axis configuration apply even when only four axes are connected.



IAI America Inc.
 USA Headquarters
 2690 W 237th St., Torrance, CA 90505, USA
 Tel.: +1-310-891-8015 Fax: +1-310-891-0815

IAI Industrieroboter GmbH
 Europe Headquarters
 Ober der Röth 4, D-65824 Schwalbach, Germany
 Tel.: +49-6196-8895-0 Fax: +49-6196-8895-24

IAI CORPORATION
 Japan Headquarters
 645-1 Shimizu Hirose, Shizuoka 424-0102, Japan
 Tel.: +81-543-64-5105 Fax: +81-543-64-5182



XSEL-P/Q
Controller Option

Electronic Cam Function

ELECTRONIC CAM



The controller recreates the movements of mechanical cams!

A cam mechanism is used in situations where a given operation should be performed in conjunction with another operation in a production facility.

If a cam mechanism is used, however, the cam itself must be redesigned from scratch when the stroke or pattern is to be changed, which makes the adjustment process time-consuming and cumbersome. An electronic cam function solves this problem.

Example of Cam Mechanism

To change the vertical travel (A) or operation pattern, the cam (B) must be given additional machining or redesigned.

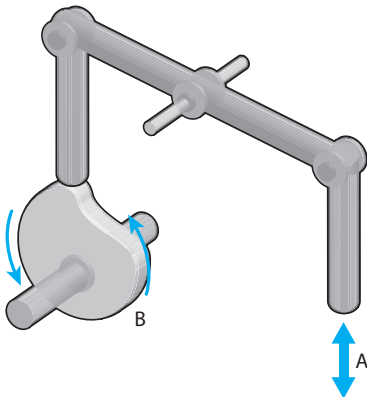

What Is Electronic Cam?

An electronic cam controls the slave axis in synchronization with the master axis, using pulse trains, according to a pre-defined electronic cam table.

Features of Electronic Cam

1 Shorter system cycle time

Since the position relationships of operating axes can be specified in a cam table, the stopping time of each axis can be minimized and consequently the cycle time can be reduced significantly.

2 Easy adjustment when changing the operation pattern

Unlike with a mechanical cam, no parts must be machined when changing the operation pattern. All you need is to change the data of the electronic cam table, and you will be able to change the positions and timings.

Since the position relationships of the master axis do not change due to speed, timings can be adjusted at a sufficiently low speed, which makes adjustments very easy.

3 Up to 16 axes can be controlled

Eight slave axes can be operated with one pulse-train board installed in the XSEL controller. Up to two pulse-train boards can be installed, which means that up to 16 axes can be controlled.

Example of Electronic Cam Table

The electronic cam table is a data table used for specifying the positions of slave axes that move in conjunction with the movements of the master axis. The horizontal axis represents the phase of the master axis, while the vertical axis represents the displacement of the slave axis.

When values are entered in the electronic cam table, points appear on the graph area of the electronic cam table and a curved line linking all these points gives an operating curve of the slave axis.

•Electronic cam table data

No.	Master axis phase	Slave axis phase
0	0	0
1	500	1000
2	1000	3000
3	1500	6000
4	2000	11000
5	2500	18000
6	3000	22000
7	3500	24500
8	4000	25000
9	4500	24500
10	5000	22000
11	5500	18000
12	6000	11000
13	7000	5000
14	8000	2000
15	9000	1000
16	10000	0

•Electronic cam table

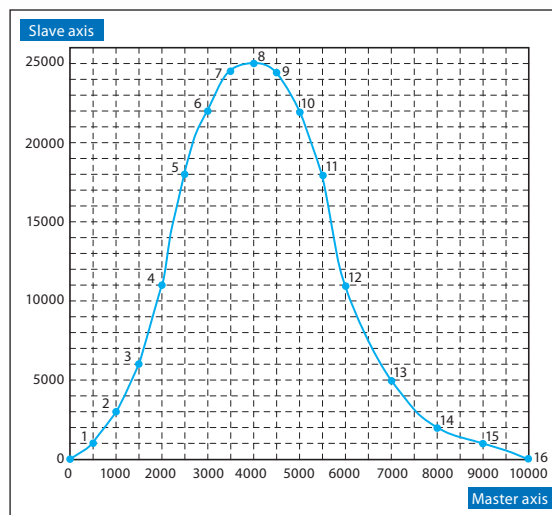

<Note> The above table and graph are provided for illustration purposes only and may differ from the actual table and graph shown on the software screen.

Example of Use of Electronic Cam

By designating a single-axis robot as the master axis and moving a cutting knife up and down in conjunction with the movements of this single-axis robot, the work part can be cut without stopping the work part.

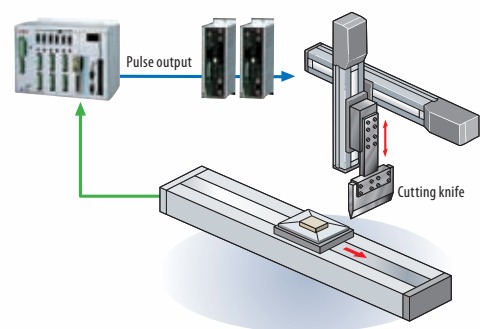

Other Useful Functions

1. Electronic shaft function

All slave axes move in the same manner as the master axis moves. A gear ratio can be set for master/slave-axis movements, which means that the ratio of the travels of master and slave axes can be changed accordingly.

2. Positioner function

Just like in any normal positioning operation, the actuator can be operated by setting position data. Movement by linear interpolation is also supported in addition to PTP operation. Up to 512 position points can be set, where the maximum number of position points changes depending on the number of connected axes.

3. Input pulse counter function

Pulses input from the pulse input channel are counted by the SEL program. It is also possible to use input pulses as the master axis of the electronic cam.

System Configuration | Required Equipment

The following equipment will be required when an electronic cam is used.

Applicable controllers: XSEL-P/Q

Name	Master axis phase	Slave axis phase
① PIO board	N1: IA-103-X-32 N2: IA-103-X-16 N3: IA-IO-3204-NP P1: IA-103-X-32-P P2: IA-103-X-16-P P3: IA-IO-3204-PN	Specify a desired code from among "N1," "N2," "N3," "P1," "P2" and "P3" in the standard or expansion I/O field of the controller model number.
② Pulse I/O board	IA-EC-4801-PL	Enter the code "MC" in the expansion I/O field of the controller model number. If nine or more controllers are connected, two pulse I/O boards are required.
③ Pulse I/O cable	CB-XPQ-PLIOS□□□-H6	This cable comes with the pulse I/O board.
④ I/O flat cable	CB-X-PIO□□□□(for 50 pins) CB-X-PIOH□□□□(for multi-point I/Os)	This cable comes with the controller or multi-point I/O board.
⑤ Connector terminal block conversion unit	—	Purchase a terminal block to which any commercially available ML 50-pin flat cable connector can be connected. (Example: Omron XW2B-50G4)
⑥ SCON pulse-train cable	CB-SC-PIOS□□□□	Specify the model number shown to the left when ordering this cable.
⑦ SCON PIO cable	CB-PAC-PIO□□□□	This cable comes with the SCON controller.
⑧ Pulse-train control I/O cable	CB-PACPU-PIO□□□□	This cable comes with the PCON/ACON controller.
⑨ Terminal block	—	Use a commercially available terminal block.

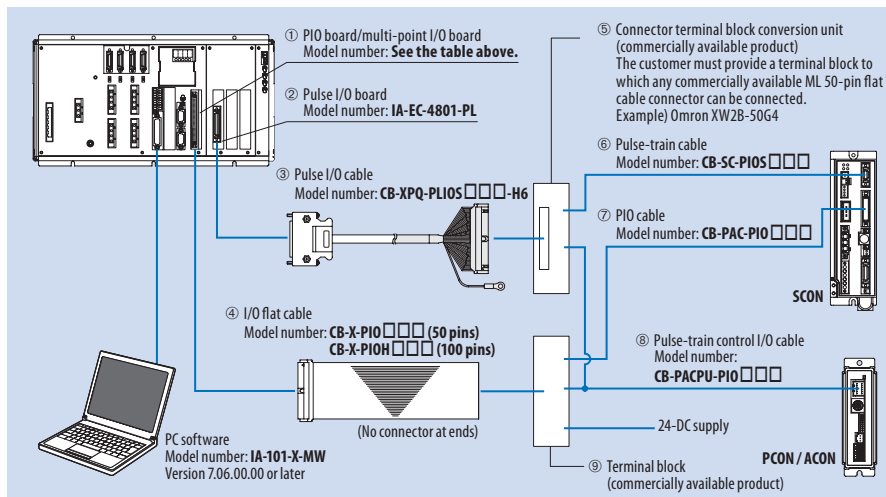

One pulse I/O board has eight pulse output channels and two pulse input channels. Up to two pulse I/O board can be installed in one controller, meaning that up to 16 RoboCylinder controllers of pulse I/O type can be connected. If a RoboCylinder controller is connected, PIO connection is required in addition to pulse I/O connection. Use the table below to check the number of signals required by each controller and add a PIO board according to the number of controllers to be operated.

	Number of I/Os required per controller	
	Input	Output
SCON controller	5 points	3 points
PCON/ACON controller	4 points	3 points

Model number

XSEL — [] — [] — [] — [] — [] — []

Type Actuator specification (Slot 1) (Slot 2) (Slot 3) (Slot 4) Cable/power supply specification

Standard I/O (Expansion I/O)

P	Single-axis/Cartesian large-capacity type	E	Not used	MC	Up to two pulse I/O boards can be installed	P1	32 inputs/16 outputs (PNP)
Q	Single-axis/Cartesian large-capacity type conforming to safety category	N1	32 inputs/16 outputs (NPN)	E	Not used	P2	16 inputs/32 outputs (PNP)
		N2	16 inputs/32 outputs (NPN)	N1	32 inputs/16 outputs (NPN)	P3	48 inputs/48 outputs (PNP)
		N3	48 inputs/48 outputs (NPN)	N2	16 inputs/32 outputs (NPN)		
		P1	32 inputs/16 outputs (PNP)	N3	48 inputs/48 outputs (NPN)		
		P2	16 inputs/32 outputs (PNP)				
		P3	48 inputs/48 outputs (PNP)				

Specifications

Item	Description	Remarks
Applicable controller	XSEL-P/Q	
PC software	Version 7.06.00.00 or later	
I/O I/F	Pulse I/Os by 2 input channels and 8 output channels (1 board)	
Number of installed boards	Up to 2 boards	Installed in expansion I/O slots.
Number of controlled axes	Up to 16 axes (when 2 pulse I/O boards are used)	
Connection pulse-train driver	SCON, ACON-PL, PCON-PL	Only differential drivers are supported.
Synchronous control function	Synchronous electronic cam (master axis specification), single electronic cam (time specification), electronic shaft	
Positioning function	Servo ON/OFF, home return, PTP movement (absolute/relative), movement by linear interpolation (absolute/relative), movement by direct numerical specification (absolute/relative)	
Input pulse counter function	Clear pulse counter, get pulse count	Max. 500 Kpps
Other functions	Jog/Incremental move (only via a tool), axis movement stop, pause, cancel, soft limit, command position teaching	

Cable

- Pulse I/O cable

Model number: CB-XPQ-PLIOS□□□-H6 *□□□ indicates the cable length (L). A desired length of up to 5 m can be specified in meters. Example: 020 = 2 m

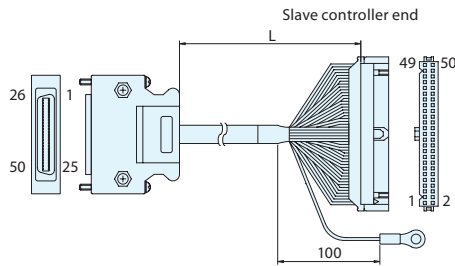

Pin No.	Wire color	Signal	Channel No.	Function	Pin No.	Wire color	Signal	Channel No.	Function
1	Blue	0A+	0	Pulse output phase A+	27	Gray/White 2	1A+	1	Pulse output phase A+
2	Orange	0A-		Pulse output phase A-	28	Red/White 2	1A-		Pulse output phase A-
3	Green	0B+		Pulse output phase B+	29	Black/White 2	1B+		Pulse output phase B+
4	Brown	0B-		Pulse output phase B-	30	Yellow/Black 2	1B-		Pulse output phase B-
5	Gray	2A+	2	Pulse output phase A+	31	Pink/Black 2	3A+	3	Pulse output phase A+
6	Red	2A-		Pulse output phase A-	32	Purple/White 2	3A-		Pulse output phase A-
7	Black	2B+		Pulse output phase B+	33	White/Blue 2	3B+		Pulse output phase B+
8	Yellow	2B-		Pulse output phase B-	34	Blue/Black 1	3B-		Pulse output phase B-
9	Pink	4A+	4	Pulse output phase A+	35	Orange/Black 1	5A+	5	Pulse output phase A+
10	Purple	4A-		Pulse output phase A-	36	Green/Black 1	5A-		Pulse output phase A-
11	White	4B+		Pulse output phase B+	37	Brown/Black 1	5B+		Pulse output phase B+
12	Blue/Red 1	4B-		Pulse output phase B-	38	Gray/Black 1	5B-		Pulse output phase B-
13	Orange/White 1	6A+	6	Pulse output phase A+	39	Red/Black 1	7A+	7	Pulse output phase A+
14	Green/White 1	6A-		Pulse output phase A-	40	Yellow/Red 1	7A-		Pulse output phase A-
15	Brown/White 1	6B+		Pulse output phase B+	41	Pink/Red 1	7B+		Pulse output phase B+
16	Gray/White 1	6B-		Pulse output phase B-	42	Purple/Black 1	7B-		Pulse output phase B-
17	Red/White 1	INA+0	0	Pulse input phase A+	43	White/Black 1	INA+1	1	Pulse input phase A+
18	Black/White 1	INA-0		Pulse input phase A-	44	Blue/Black 2	INA-1		Pulse input phase A-
19	Yellow/Black 1	INB+0		Pulse input phase B+	45	Orange/Black 2	INB+1		Pulse input phase B+
20	Pink/Black 1	INB-0		Pulse input phase B-	46	Green/Black 2	INB-1		Pulse input phase B-
21	Purple/White 1	INZ+0	0	Do not connect anything to this signal.	47	Brown/Black 2	INZ+1	1	Do not connect anything to this signal.
22	White/Blue 1	INZ-0		Do not connect anything to this signal.	48	Gray/Black 2	INZ-1		Do not connect anything to this signal.
23	Blue/Red 2	ESV_0		Encoder power output (5 VDC): 100 mA max.	49	Red/Black 2	ESV_1		Encoder power output (5 VDC): 100 mA max.
24	Orange/White 2	EOV_0		Encoder power ground	50	Yellow/Red 2	EOV_1		Encoder power ground
25	Green/White 2	RSV_COM1	-	Connect a crimped round terminal to the shield.					
26	Brown/White 2	RSV_COM2	-	Do not connect anything to this signal.					

- I/O flat cable (50-pin specification for PIO board)

Model number: CB-X-PIO□□□ *□□□ indicates the cable length (L). A desired length of up to 10 m can be specified in meters. Example: 020 = 2 m

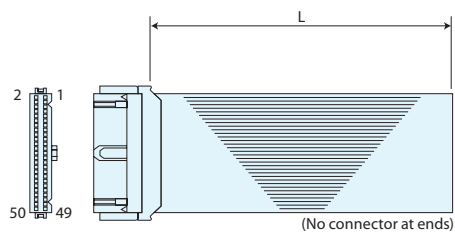

Pin No.	Wire color	Standard I/O		Expansion I/O		Pin No.	Wire color	Standard I/O		Expansion I/O	
		When I/O code N1/P1 is selected	When I/O code N2/P2 is selected	When I/O code N1/P1 is selected	When I/O code N2/P2 is selected			When I/O code N1/P1 is selected	When I/O code N2/P2 is selected		
1	Brown 1	24 V, externally supplied	24 V, externally supplied	24 V, externally supplied	24 V, externally supplied	26	Blue 3	General-purpose input	General-purpose output	General-purpose output	General-purpose output
2	Red 1	Program start	General-purpose input	General-purpose input	General-purpose input	27	Purple 3				
3	Orange 1					28	Gray 3				
4	Yellow 1					29	White 3				
5	Green 1					30	Black 3				
6	Blue 1	General-purpose output	General-purpose output	General-purpose output	General-purpose output	31	Brown 4				
7	Purple 1					32	Red 4				
8	Gray 1					33	Orange 4				
9	White 1					34	Yellow 4				
10	Black 1	Program specification (PRG No. 1)	General-purpose output	General-purpose output	General-purpose output	35	Green 4				
11	Brown 2	Program specification (PRG No. 2)				36	Blue 4				
12	Red 2	Program specification (PRG No. 4)				37	Purple 4				
13	Orange 2	Program specification (PRG No. 8)				38	Gray 4				
14	Yellow 2	Program specification (PRG No. 10)	General-purpose output	General-purpose output	General-purpose output	39	White 4				
15	Green 2	Program specification (PRG No. 20)				40	Black 4				
16	Blue 2	General-purpose input				41	Brown 5				
17	Purple 2	General-purpose input				42	Red 5				
18	Gray 2	Alarm output	General-purpose output	General-purpose output	General-purpose output	43	Orange 5				
19	White 2	Ready output				44	Yellow 5				
20	Black 2	Emergency stop output				45	Green 5				
21	Brown 3	General-purpose output				46	Blue 5				
22	Red 3		47	Purple 5							
23	Orange 3		48	Gray 5							
24	Yellow 3		49	White 5							
25	Green 3	50	Black 5	0 V, externally supplied	0 V, externally supplied	0 V, externally supplied	0 V, externally supplied				

- I/O flat cable (100-pin specification for multi-point I/O board)

Model number: CB-X-PIOH□□□ *□□□ indicates the cable length (L). A desired length of up to 10 m can be specified in meters. Example: 020 = 2 m

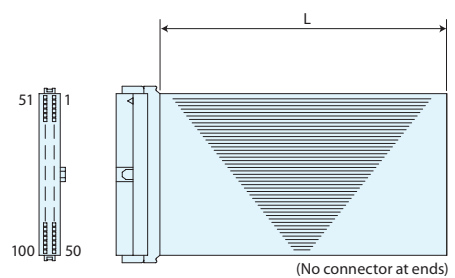

Pin No.	Standard I/O	Expansion I/O	Pin No.	Standard I/O	Expansion I/O	Pin No.	Standard I/O	Expansion I/O	Pin No.	Standard I/O	Expansion I/O
1	24 V, externally supplied	24 V, externally supplied	26	24 V, externally supplied	24 V, externally supplied	51	Alarm output	General-purpose output	76	General-purpose output	General-purpose output
2	Program start	General-purpose input	27	General-purpose input	General-purpose input	52	Ready output				
3			28			53	Emergency stop output				
4			29			54	General-purpose output		78		
5			30			55		80			
6	31	56	81								
7	32	57	82								
8	33	58	83								
9	34	59	84								
10	35	60	85								
11	36	61	86								
12	37	62	87								
13	38	63	88								
14	39	64	89								
15	40	65	90								
16	41	66	91								
17	42	67	92								
18	43	68	93								
19	44	69	94								
20	45	70	95								
21	46	71	96								
22	47	72	97								
23	48	73	98								
24	49	74	99								
25	50	75	0 V, externally supplied	0 V, externally supplied	100	0 V, externally supplied	0 V, externally supplied				