

3-Finger Gripper Type

RCP2-GR3



RCP2-GR3LS



RCP2-GR3SS

RCP2 series

Pulse
Motor
Type

3-Finger Gripper	Lever Type	62mm Width	RCP2-GR3LS	343
		80mm Width	RCP2-GR3LM	345
	Slider Type	62mm Width	RCP2-GR3SS	347
		80mm Width	RCP2-GR3SM	349



RCP2-GR3LS

ROBO Cylinder 3-Finger Gripper Lever Type 62mm Width Pulse Motor

■ Configuration: **RCP2** — **GR3LS** — **I** — **28P** — **30** — **19** — — —

Series — Type — Encoder — Motor — Deceleration Ratio — Stroke — Compatible Controllers — Cable Length — Option

I: Incremental
* The Simple absolute encoder is also considered type "I".

28P: 28 □ size Pulse motor

30: 1/30 deceleration ratio

19: 19 degrees

P1: PCON
RPCON
PSEL

P3: PMEC
PSEP

N: None
P: 1m
S: 3m
M: 5m
X□□: Custom
R□□: Robot cable

FB: Flange bracket
SB: Shaft bracket

* See page Pre-35 for an explanation of the naming convention.



Technical References P. A-5

- POINT**
Notes on Selection
- (1) The maximum opening/closing speed indicates the operating speed on one side. The relative operating speed is twice this value.
 - (2) The maximum gripping force is the sum of the gripping forces of all fingers with gripping point distance of 10mm and no overhang distance. For the actual transportable work piece weight, see explanation on the right, or page A-77.
 - (3) The rated acceleration while moving is 0.3G.

■ Gripping Force vs. Current Limit Lever Type (GR3LS/GR3LM)

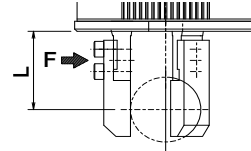

* Please note that, when gripping (pushing), the speed is fixed at 5 degrees/s.

* The values in the graph below are gripping forces at 10mm gripping point. The actual gripping force decreases inversely proportional to the distance from the opening/closing point. You can calculate the actual gripping force by the following equation.
Actual gripping force (type S) = $P \times 24 / (L + 14)$
Actual gripping force (type M) = $P \times 28.5 / (L + 18.5)$
P = Gripping force on graph
L = Distance from finger mounting surface to the gripping point.

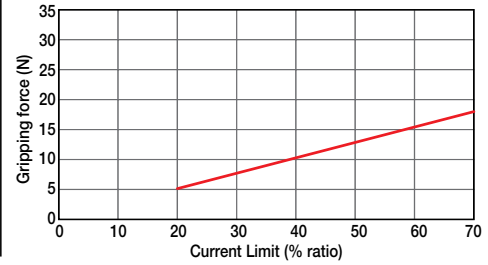

Actuator Specifications

■ Lead and Load Capacity

Model	Deceleration Ratio	Max. Gripping Force (N)	Stroke (deg)
RCP2-GR3LS-I-28P-30-19-①-②-③	30	18	19

Legend: ① Compatible controllers ② Cable length ③ Options

■ Stroke and Maxi. Opening/Closing Speed

Stroke	19 (deg)
Deceleration Ratio	
30	200

(Unit: degrees/s)

Stroke List

Stroke (deg)	Standard Price
10	—

② Cable List

Type	Cable Symbol	Standard Price
Standard Type	P (1m)	—
	S (3m)	—
	M (5m)	—
Special Lengths	X06 (6m) ~ X10 (10m)	—
	X11 (11m) ~ X15 (15m)	—
	X16 (16m) ~ X20 (20m)	—
Robot Cable	R01 (1m) ~ R03 (3m)	—
	R04 (4m) ~ R05 (5m)	—
	R06 (6m) ~ R10 (10m)	—
	R11 (11m) ~ R15 (15m)	—
	R16 (16m) ~ R20 (20m)	—

* See page A-39 for cables for maintenance.

③ Option List

Name	Option Code	See Page	Standard Price
Flange bracket	FB	→ A-26	—
Shaft bracket	SB	→ A-36	—

Actuator Specifications

Item	Description
Drive System	Worm gear + worm wheel gear
Positioning Repeatability	±0.01 degrees
Backlash	1 degree or less per side (constantly pressed out by a spring)
Lost Motion	0.15 degrees or less per side
Weight	0.6kg
Ambient Operating Temp./Humidity	0~40°C, 85% RH or less (non-condensing)

Dimensions

CAD drawings can be downloaded from IAI website. www.intelligentactuator.com



- * When homing, the actuator swings 1 degree past the home position before returning. Therefore, please watch for any interference with the surrounding objects.
- *1 The motor-encoder cable is connected here. See page A-39 for details on cables.

For Special Orders P. A-9

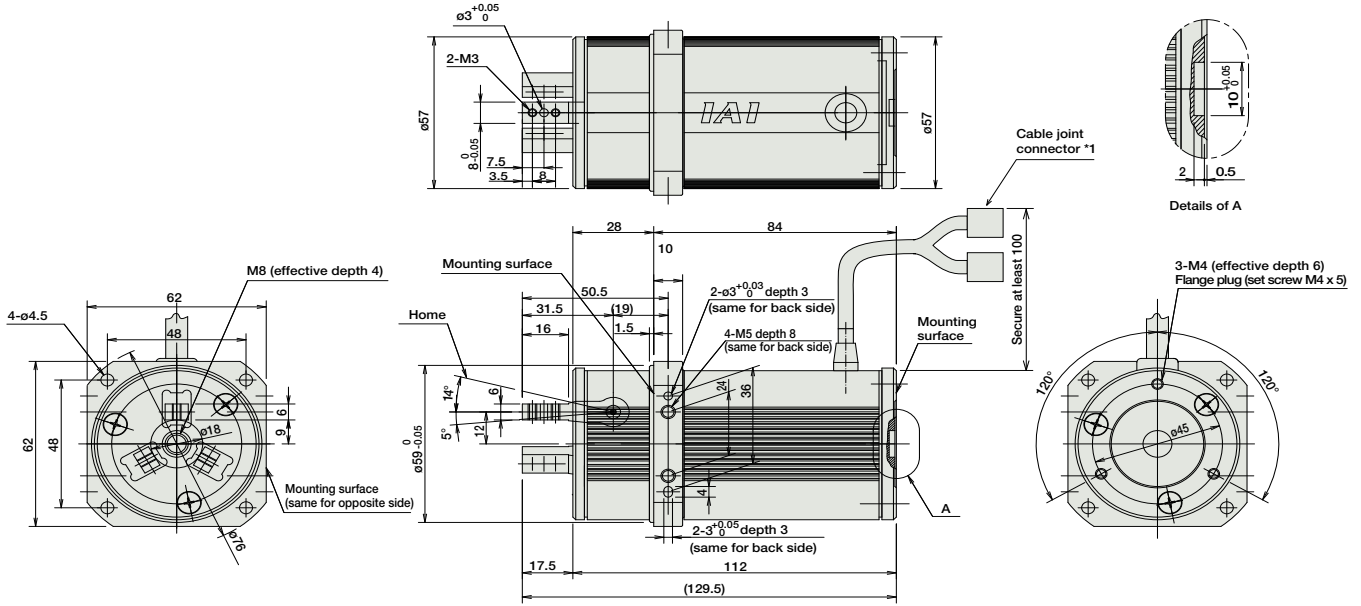

Weight (kg) 0.6

① Compatible Controllers

The RCP2 series actuators can operate with the controllers below. Select the controller according to your usage.

Name	External View	Model	Description	Max. Positioning Points	Input Voltage	Power Supply Capacity	Standard Price	See Page
Solenoid Valve Type		PMEC-C-28PI-NP-2-①	Easy-to-use controller, even for beginners	3 points	AC100V AC200V	See P481	-	→ P477
	Splash-Proof Solenoid Valve Type		PSEP-C-28PI-NP-2-0				Operable with same signal as solenoid valve. Supports both single and double solenoid types. No homing necessary with simple absolute type.	-
Positioner Type			PCON-C-28PI-NP-2-0	Positioning is possible for up to 512 points	512 points	-		
Safety-Compliant Positioner Type		PCON-CG-28PI-NP-2-0	-					
Pulse Train Input Type (Differential Line Driver)		PCON-PL-28PI-NP-2-0	Pulse train input type with differential line driver support	(-)	DC24V	2A max.	-	→ P525
Pulse Train Input Type (Open Collector)		PCON-PO-28PI-NP-2-0	Pulse train input type with open collector support				-	
Serial Communication Type		PCON-SE-28PI-N-0-0	Dedicated to serial communication	64 points	-	-	-	
Field Network Type		RPCON-28P	Dedicated to field network	768 points	-	-	-	→ P503
Program Control Type		PSEL-C-1-28PI-NP-2-0	Programmed operation is possible. Operation is possible on up to 2 axes	1500 points	-	-	-	→ P557

* This is for the single-axis PSEL.

* ① is a placeholder for the power supply voltage (1: 100V, 2: 100~240V).

- Slider Type
- Mini
- Standard
- Controllers Integrated
- Rod Type
- Mini
- Standard
- Controllers Integrated
- Table/Arm/Flat Type
- Mini
- Standard
- Controllers Integrated
- Table/Arm/Flat Type
- Mini
- Standard
- Gripper/Rotary Type
- Linear Servo Type
- Cleanroom Type
- Splash-Proof
- Controllers
- PMEC/AMEC
- PSEP/ASEP
- ROBO NET
- ERC2
- PCON
- ACON
- SCON
- PSEL
- ASEL
- SSEL
- XSEL
- Pulse Motor
- Servo Motor (24V)
- Servo Motor (200V)
- Linear Servo Motor

RCP2-GR3LM

ROBO Cylinder 3-Finger Gripper Lever Type 80mm Width Pulse Motor

■ Configuration: **RCP2-GR3LM-I-42P-30-19**

Series — Type — Encoder — Motor — Deceleration Ratio — Stroke — Compatible Controllers — Cable Length — Option

I: Incremental
* The Simple absolute encoder is also considered type "I".

42P: 42 □ size Pulse motor

30: 1/30 deceleration ratio

19: 19 degrees

P1: PCON
RPCON
PSEL

P3: PMEC
PSEP

N: None
P: 1m
S: 3m
M: 5m
X□□: Custom
R□□: Robot cable

FB: Flange bracket
SB: Shaft bracket

* See page Pre-35 for an explanation of the naming convention.



Technical References P. A-5



- (1) The maximum opening/closing speed indicates the operating speed on one side. The relative operating speed is twice this value.
- (2) The maximum gripping force is the sum of the gripping forces of all fingers with gripping point distance of 10mm and no overhang distance. For the actual transportable work piece weight, see explanation on the right, or page A-77.
- (3) The rated acceleration while moving is 0.3G.

■ Gripping Force vs. Current Limit Lever Type (GR3LS/GR3LM)

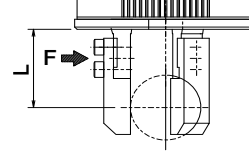

* Please note that, when gripping (pushing), the speed is fixed at 5 degrees/s.

* The values in the graph below are gripping forces at 10mm gripping point. The actual gripping force decreases inversely proportional to the distance from the opening/closing point. You can calculate the actual gripping force by the following equation.
Actual gripping force (type S)= $P \times 24 / (L + 14)$
Actual gripping force (type M)= $P \times 28.5 / (L + 18.5)$
P=Gripping force on graph
L=Distance from finger mounting surface to the gripping point.

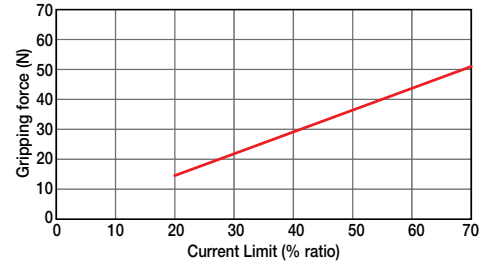

Actuator Specifications

■ Lead and Load Capacity

Model	Deceleration Ratio	Max. Gripping Force (N)	Stroke (deg)
RCP2-GR3LM-I-42P-30-19-①-②-③	30	51	19

Legend: ① Compatible controllers ② Cable length ③ Options

■ Stroke and Maxi. Opening/Closing Speed

Stroke	19 (deg)
Deceleration Ratio	200

(Unit: degrees/s)

Stroke List

Stroke (deg)	Standard Price
10	-

② Cable List

Type	Cable Symbol	Standard Price
Standard Type	P (1m)	-
	S (3m)	-
	M (5m)	-
Special Lengths	X06 (6m) ~ X10 (10m)	-
	X11 (11m) ~ X15 (15m)	-
	X16 (16m) ~ X20 (20m)	-
Robot Cable	R01 (1m) ~ R03 (3m)	-
	R04 (4m) ~ R05 (5m)	-
	R06 (6m) ~ R10 (10m)	-
	R11 (11m) ~ R15 (15m)	-
	R16 (16m) ~ R20 (20m)	-

* See page A-39 for cables for maintenance.

③ Option List

Name	Option Code	See Page	Standard Price
Flange bracket	FB	→ A-26	-
Shaft bracket	SB	→ A-36	-

Actuator Specifications

Item	Description
Drive System	Worm gear + worm wheel gear
Positioning Repeatability	±0.01 degrees
Backlash	1 degree or less per side (constantly pressed out by a spring)
Lost Motion	0.15 degrees or less per side
Weight	1.1kg
Ambient Operating Temp./Humidity	0~40°C, 85% RH or less (non-condensing)

Dimensions

CAD drawings can be downloaded from IAI website. www.intelligentactuator.com

For Special Orders P. A-9



- * When homing, the actuator swings 1 degree past the home position before returning. Therefore, please watch for any interference with the surrounding objects.
- *1 The motor-encoder cable is connected here. See page A-39 for details on cables.

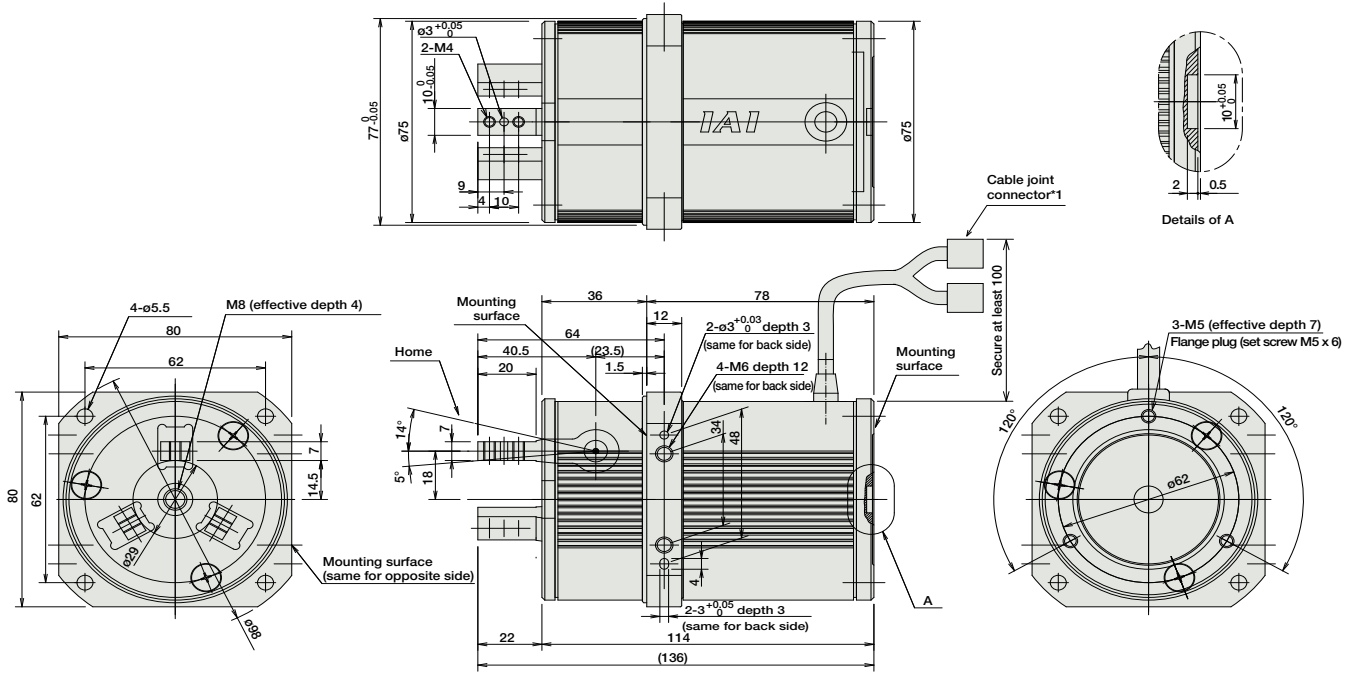

Weight (kg) 1.1

① Compatible Controllers

The RCP2 series actuators can operate with the controllers below. Select the controller according to your usage.

Name	External View	Model	Description	Max. Positioning Points	Input Voltage	Power Supply Capacity	Standard Price	See Page
Solenoid Valve Type		PMEC-C-42PI-NP-2-①	Easy-to-use controller, even for beginners	3 points	AC100V AC200V	See P481	-	→ P477
		PSEP-C-42PI-NP-2-0	Operable with same signal as solenoid valve. Supports both single and double solenoid types. No homing necessary with simple absolute type.					
Splash-Proof Solenoid Valve Type		PSEP-CW-42PI-NP-2-0					-	→ P487
Positioner Type		PCON-C-42PI-NP-2-0	Positioning is possible for up to 512 points	512 points			-	
Safety-Compliant Positioner Type		PCON-CG-42PI-NP-2-0					-	
Pulse Train Input Type (Differential Line Driver)		PCON-PL-42PI-NP-2-0	Pulse train input type with differential line driver support	(-)	DC24V	2A max.	-	→ P525
Pulse Train Input Type (Open Collector)		PCON-PO-42PI-NP-2-0	Pulse train input type with open collector support				-	
Serial Communication Type		PCON-SE-42PI-N-0-0	Dedicated to serial communication	64 points			-	
Field Network Type		RPCON-42P	Dedicated to field network	768 points			-	→ P503
Program Control Type		PSEL-C-1-42PI-NP-2-0	Programmed operation is possible. Operation is possible on up to 2 axes	1500 points			-	→ P557

* This is for the single-axis PSEL.
* ① is a placeholder for the power supply voltage (1: 100V, 2: 100~240V).

- Slider Type
- Mini
- Standard
- Controllers Integrated
- Rod Type
- Mini
- Standard
- Controllers Integrated
- Table/Arm/Flat Type
- Mini
- Standard
- Controllers Integrated
- Gripper/Rotary Type
- Linear Servo Type
- Cleanroom Type
- Splash-Proof
- Controllers
- PMEC/AMEC
- PSEP/ASEP
- ROBO NET
- ERC2
- PCON
- ACON
- SCON
- PSEL
- ASEL
- SSEL
- XSEL
- Pulse Motor
- Servo Motor (24V)
- Servo Motor (200V)
- Linear Servo Motor

RCP2-GR3SS

ROBO Cylinder 3-Finger Gripper Slider Type 62mm Width Pulse Motor

■ Configuration: **RCP2** — **GR3SS** — **I** — **28P** — **30** — **10** — — —

Series — Type — Encoder — Motor — Deceleration Ratio — Stroke — Compatible Controllers — Cable Length — Option

I: Incremental
* The Simple absolute encoder is also considered type "I".

28P: 28 □ size Pulse motor
30: 1/30 deceleration (5mm per side) ratio
10: 10mm stroke (5mm per side)

P1: PCON
RPCON
PSEL
P3: PMEC
PSEP

N: None
P: 1m
S: 3m
M: 5m
X□□: Custom
R□□: Robot cable

FB: Flange bracket
SB: Shaft bracket

* See page Pre-35 for an explanation of the naming convention.



Technical References P. A-5



- (1) The maximum opening/closing speed indicates the operating speed on one side. The relative operating speed is twice this value.
- (2) The maximum gripping force is the sum of the gripping forces of all fingers with gripping point distance of 10mm and no overhang distance. For the actual transportable work piece weight, see explanation on the right or page A-74.
- (3) The rated acceleration while moving is 0.3G.

■ Gripping Force vs. Current Limit

Slider Type (GR3SS/GR3SM)

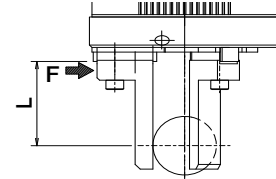

* Please keep the distance L from the finger mounting surface to the gripping point at less than the following dimensions.

- GR3SS → 50mm or less
- GR3SM → 80mm or less

* Please note that, when gripping (pushing), the speed is fixed at 5mm/s.

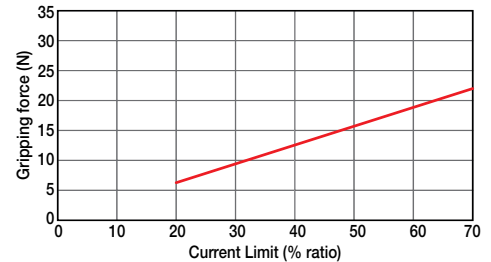

Actuator Specifications

■ Lead and Load Capacity

Model	Deceleration Ratio	Max. Gripping Force (N)	Stroke (mm)
RCP2-GR3SS-I-28P-30-10-①-②-③	30	22	10

Legend: ① Compatible controllers ② Cable length ③ Options

■ Stroke and Maxi. Opening/Closing Speed

Deceleration Ratio	Stroke	10 (mm)
	30	40

(Unit: mm/s)

Stroke List

Stroke (mm)	Standard Price
10	—

② Cable List

Type	Cable Symbol	Standard Price
Standard Type	P (1m)	—
	S (3m)	—
	M (5m)	—
Special Lengths	X06 (6m) ~ X10 (10m)	—
	X11 (11m) ~ X15 (15m)	—
	X16 (16m) ~ X20 (20m)	—
Robot Cable	R01 (1m) ~ R03 (3m)	—
	R04 (4m) ~ R05 (5m)	—
	R06 (6m) ~ R10 (10m)	—
	R11 (11m) ~ R15 (15m)	—
	R16 (16m) ~ R20 (20m)	—

* See page A-39 for cables for maintenance.

③ Option List

Name	Option Code	See Page	Standard Price
Flange bracket	FB	→ A-26	—
Shaft bracket	SB	→ A-36	—

Actuator Specifications

Item	Description
Drive System	Worm gear + worm wheel gear
Positioning Repeatability	±0.01 mm
Backlash	0.3mm or less per side (constantly pressed out by a spring)
Lost Motion	0.1mm or less per side
Guide	Cross roller guide
Allowable Static Load Moment	Ma: 3.8 N·m Mb: 3.8 N·m Mc: 3.0 N·m
Weight	0.6kg
Ambient Operating Temp./Humidity	0~40°C, 85% RH or less (non-condensing)

Dimensions

CAD drawings can be downloaded from IAI website. www.intelligentactuator.com

For Special Orders P. A-9



- * When homing, the actuator swings 0.5mm past the home position before returning. Therefore, please watch for any interference with the surrounding objects.
- *1 The motor-encoder cable is connected here. See page A-39 for details on cables.

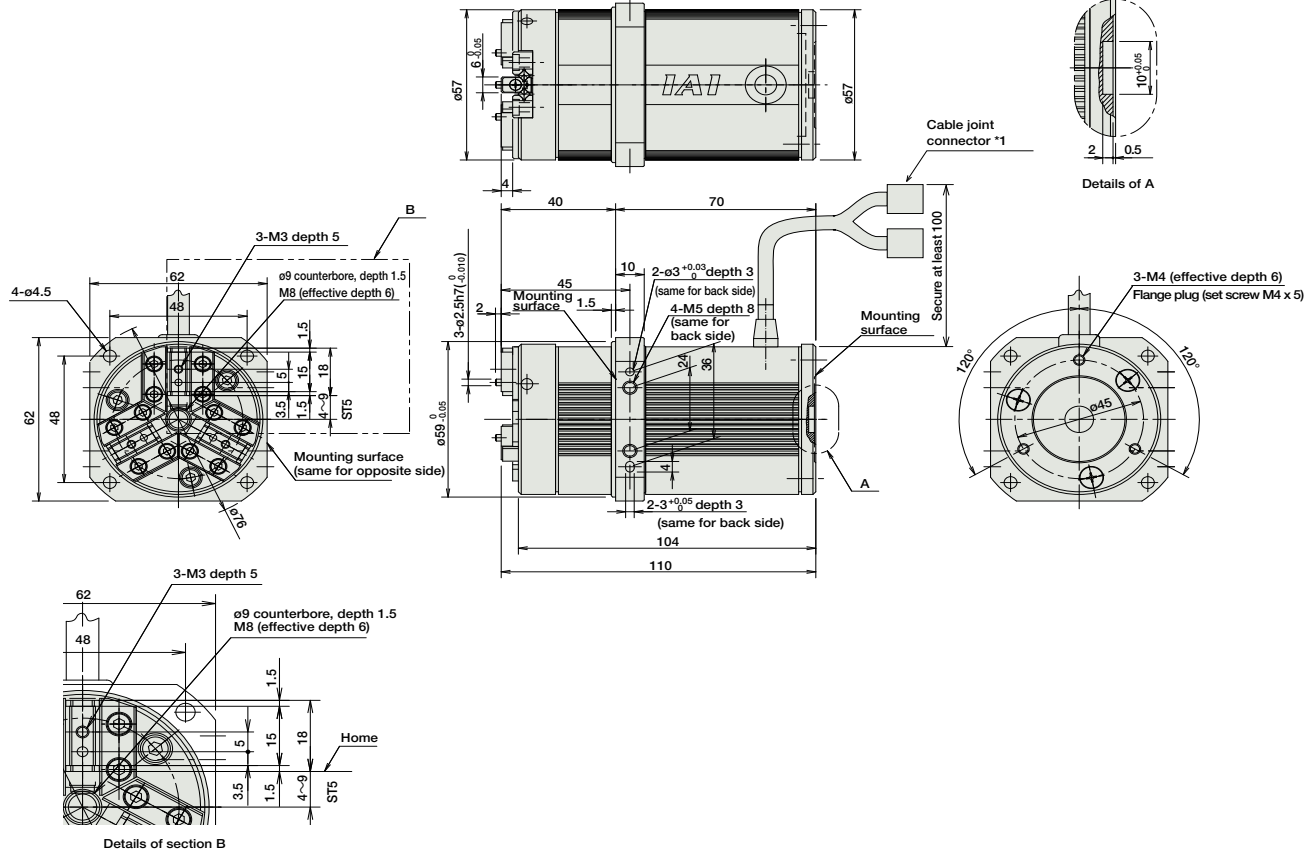

Weight (kg) 0.6

① Compatible Controllers

The RCP2 series actuators can operate with the controllers below. Select the controller according to your usage.

Name	External View	Model	Description	Max. Positioning Points	Input Voltage	Power Supply Capacity	Standard Price	See Page
Solenoid Valve Type		PMEC-C-28PI-NP-2-①	Easy-to-use controller, even for beginners	3 points	AC100V AC200V	See P481	-	→ P477
		PSEP-C-28PI-NP-2-0	Operable with same signal as solenoid valve. Supports both single and double solenoid types. No homing necessary with simple absolute type.					
Splash-Proof Solenoid Valve Type		PSEP-CW-28PI-NP-2-0						→ P487
Positioner Type		PCON-C-28PI-NP-2-0	Positioning is possible for up to 512 points	512 points	DC24V	2A max.	-	
Safety-Compliant Positioner Type		PCON-CG-28PI-NP-2-0						
Pulse Train Input Type (Differential Line Driver)		PCON-PL-28PI-NP-2-0	Pulse train input type with differential line driver support	(-)	DC24V	2A max.	-	→ P525
Pulse Train Input Type (Open Collector)		PCON-PO-28PI-NP-2-0	Pulse train input type with open collector support					
Serial Communication Type		PCON-SE-28PI-N-0-0	Dedicated to serial communication	64 points				
Field Network Type		RCON-28P	Dedicated to field network	768 points				→ P503
Program Control Type		PSEL-C-1-28PI-NP-2-0	Programmed operation is possible. Operation is possible on up to 2 axes	1500 points				→ P557

* This is for the single-axis PSEL.
 * ① is a placeholder for the power supply voltage (1: 100V, 2: 100~240V).

- Slider Type
- Mini
- Standard
- Controllers Integrated
- Rod Type
- Mini
- Standard
- Controllers Integrated
- Table/Arm/Flat Type
- Mini
- Standard
- Gripper/Rotary Type
- Linear Servo Type
- Cleanroom Type
- Splash-Proof
- Controllers
- PMEC/AMEC
- PSEP/ASEP
- ROBO NET
- ERC2
- PCON
- ACON
- SCON
- PSEL
- ASEL
- SSEL
- XSEL
- Pulse Motor
- Servo Motor (24V)
- Servo Motor (200V)
- Linear Servo Motor

RCP2-GR3SM

ROBO Cylinder 3-Finger Gripper Slider Type 80mm Width Pulse Motor

■ Configuration: **RCP2-GR3SM-I-42P-30-14**

Series — Type — Encoder — Motor — Deceleration Ratio — Stroke — Compatible Controllers — Cable Length — Option

I: Incremental
* The Simple absolute encoder is also considered type "I".

42P: 42 □ size Pulse motor
30: 1/30 deceleration (7mm per side) ratio
14: 14mm stroke

P1: PCON
RPCON
PSEL
P3: PMEC
PSEP

N: None
P: 1m
S: 3m
M: 5m
X □ □ : Custom
R □ □ : Robot cable

FB: Flange bracket
SB: Shaft bracket

* See page Pre-35 for an explanation of the naming convention.



Technical References P. A-5



- (1) The maximum opening/closing speed indicates the operating speed on one side. The relative operating speed is twice this value.
- (2) The maximum gripping force is the sum of the gripping forces of all fingers with gripping point distance of 10mm and no overhang distance. For the actual transportable work piece weight, see explanation on the right or page A-74.
- (3) The rated acceleration while moving is 0.3G.

■ Gripping Force vs. Current Limit Slider Type (GR3SS/GR3SM)

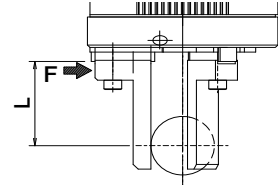

* Please keep the distance L from the finger mounting surface to the gripping point at less than the following dimensions.

- GR3SS → 50mm or less
- GR3SM → 80mm or less

* Please note that, when gripping (pushing), the speed is fixed at 5mm/s.

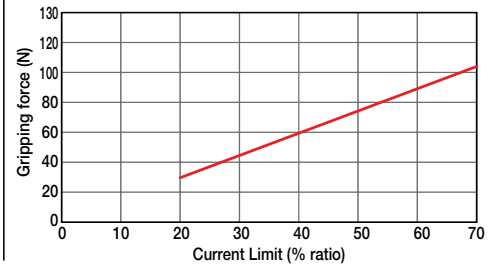

Actuator Specifications

■ Lead and Load Capacity

Model	Deceleration Ratio	Max. Gripping Force (N)	Stroke (mm)
RCP2-GR3SM-I-42P-30-14-①-②-③	30	102	14

Legend: ① Compatible controllers ② Cable length ③ Options

■ Stroke and Maxi. Opening/Closing Speed

Stroke	14 (mm)
Deceleration Ratio	30
	50

(Unit: mm/s)

Stroke List

Stroke (mm)	Standard Price
14	-

② Cable List

Type	Cable Symbol	Standard Price
Standard Type	P (1m)	-
	S (3m)	-
	M (5m)	-
Special Lengths	X06 (6m) ~ X10 (10m)	-
	X11 (11m) ~ X15 (15m)	-
	X16 (16m) ~ X20 (20m)	-
Robot Cable	R01 (1m) ~ R03 (3m)	-
	R04 (4m) ~ R05 (5m)	-
	R06 (6m) ~ R10 (10m)	-
	R11 (11m) ~ R15 (15m)	-
	R16 (16m) ~ R20 (20m)	-

* See page A-39 for cables for maintenance.

③ Option List

Name	Option Code	See Page	Standard Price
Flange bracket	FB	→ A-26	-
Shaft bracket	SB	→ A-36	-

Actuator Specifications

Item	Description
Drive System	Worm gear + worm wheel gear
Positioning Repeatability	±0.01mm
Backlash	0.3mm or less per side (constantly pressed out by a spring)
Lost Motion	0.1mm or less per side
Guide	Cross roller guide
Allowable Static Load Moment	Ma: 6.3 N·m Mb: 6.3 N·m Mc: 5.7 N·m
Weight	1.2kg
Ambient Operating Temp./Humidity	0~40°C, 85% RH or less (non-condensing)

Dimensions

CAD drawings can be downloaded from IAI website. www.intelligentactuator.com



- * When homing, the actuator swings 0.5mm past the home position before returning. Therefore, please watch for any interference with the surrounding objects.
- *1 The motor-encoder cable is connected here. See page A-39 for details on cables.

For Special Orders P. A-9

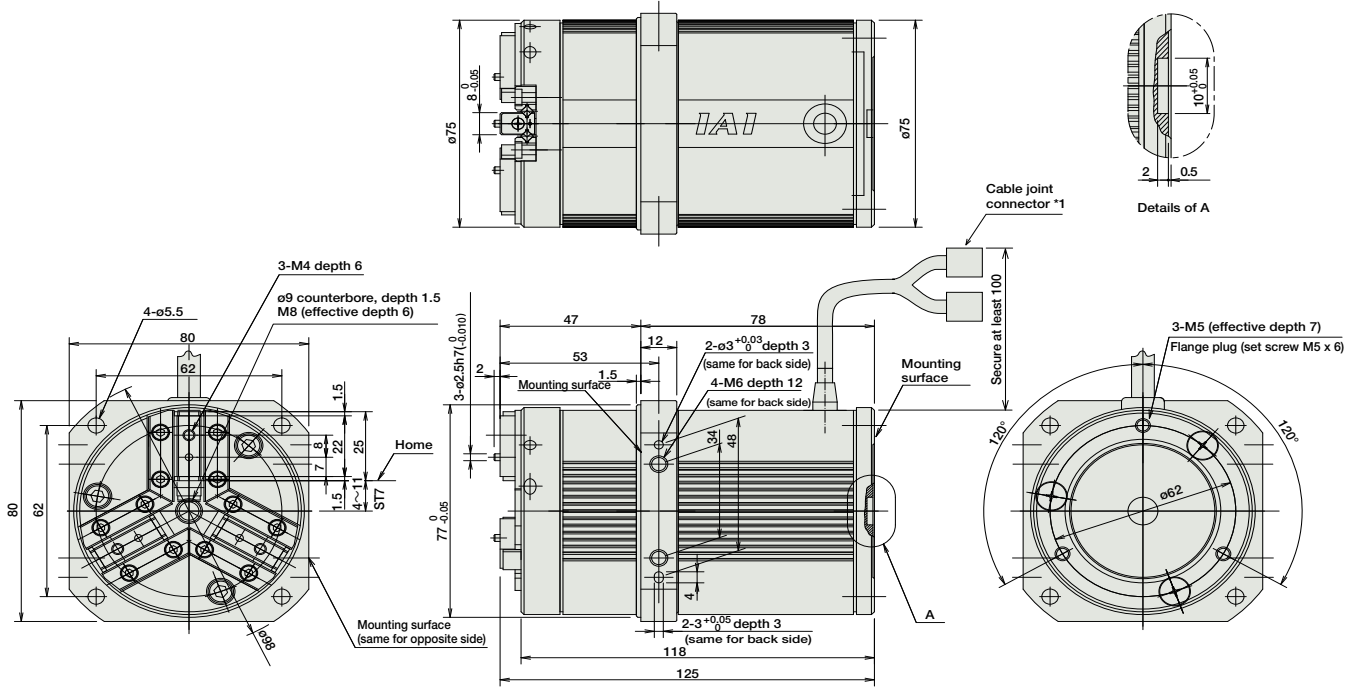

Weight (kg) 1.2

① Compatible Controllers

The RCP2 series actuators can operate with the controllers below. Select the controller according to your usage.

Name	External View	Model	Description	Max. Positioning Points	Input Voltage	Power Supply Capacity	Standard Price	See Page
Solenoid Valve Type		PMEC-C-42PI-NP-2-①	Easy-to-use controller, even for beginners	3 points	AC100V AC200V	See P481	-	→ P477
	Splash-Proof Solenoid Valve Type		PSEP-C-42PI-NP-2-0				Operable with same signal as solenoid valve. Supports both single and double solenoid types. No homing necessary with simple absolute type.	-
Positioner Type			PCON-C-42PI-NP-2-0	Positioning is possible for up to 512 points	512 points	-		
Safety-Compliant Positioner Type		PCON-CG-42PI-NP-2-0	-					
Pulse Train Input Type (Differential Line Driver)		PCON-PL-42PI-NP-2-0	Pulse train input type with differential line driver support	(-)	DC24V	2A max.	-	→ P525
Pulse Train Input Type (Open Collector)		PCON-PO-42PI-NP-2-0	Pulse train input type with open collector support				-	
Serial Communication Type		PCON-SE-42PI-N-0-0	Dedicated to serial communication	64 points	-	-	-	
Field Network Type		RPCON-42P	Dedicated to field network	768 points	-	-	-	→ P503
Program Control Type		PSEL-C-1-42PI-NP-2-0	Programmed operation is possible. Operation is possible on up to 2 axes	1500 points	-	-	-	→ P557

* This is for the single-axis PSEL.
* ① is a placeholder for the power supply voltage (1: 100V, 2: 100~240V).

- Slider Type
- Mini
- Standard
- Controllers Integrated
- Rod Type
- Mini
- Standard
- Controllers Integrated
- Table/Arm/Flat Type
- Mini
- Standard
- Gripper/Rotary Type
- Linear Servo Type
- Cleanroom Type
- Splash-Proof
- Controllers
- PMEC/AMEC
- PSEP/ASEP
- ROBO NET
- ERC2
- PCON
- ACON
- SCON
- PSEL
- ASEL
- SSEL
- XSEL
- Pulse Motor
- Servo Motor (24V)
- Servo Motor (200V)
- Linear Servo Motor