

Mini SCARA Robot

IX-NNN-120/150/180 IX-NNC-120/150/180

Mini Cleanroom SCARA Robot

A Palm-Sized Unit Capable of Driving a Maximum Payload of 1 kg



Ultra-compact size ideal for installation in limited space

A maximum work envelope of 360 mm can be ensured in a small installation space of 47 (W) x 132 (D) mm, enabling substantial size reduction of your production line.

Offering rated and maximum load capacities of 0.2 kg and 1 kg, respectively (*1)

Despite their small size, a 0.2-kg load can be transferred at high speed. If the acceleration is reduced, a load of up to 1 kg can be transferred.

(*1) The rated load capacity indicates the maximum weight that can be operated at the maximum speed and rated continuous acceleration. The maximum load capacity indicates the maximum weight that can be transferred at lower speed and acceleration.

High-speed performance achieving a cycle time of 0.35 second (*2)

The dynamic performance and highly rigid body ensures outstanding high-speed performance that is among the best in its class.

(*2) The cycle time was measured on the IX-NNN1205 based on reciprocating movements over a horizontal distance of 100 mm and vertical distance of 25 mm, carrying a 0.2-kg load.

Standard and cleanroom specifications with arm lengths of 120 mm, 150 mm and 180 mm

Optional connector-type cables for connection between the controller and actuator

The motor/encoder cables can be specified as connector types (optional) for added ease of handling and replacement.

Model (Refer to the back cover for the controller model.)

IX - NNN1205 - 5L - T2 - B	
Series	Type
IX	NNN1205/: Standard type 1505/1805 Arm length 120/150/180mm Z-Axis 50mm
	NNC1205/: Cleanroom type 1505/1805 Arm length 120/150/180mm Z-Axis 50mm
	Applicable controller
	T2 : XSEL-PX/QX
	Cable length
	3L : 3m 5L : 5m
	Option
	B : Z-axis brake JY : Cable Joint Connector

Note

*1) If the load on the Z-axis is within the rated load capacity (0.2 kg), the Z-axis will not drop even after the power is cut off. If the rated load capacity is exceeded, however, the Z-axis may drop when the power is cut off or an emergency stop is actuated. If the Z-axis will be carrying a large load, specify a z-axis brake (option code: B).

*2) The standard motor/encoder cables are not of connector type. If you require connector-type cables that permit replacement, specify the option for connector-type cables (option code: JY).

Options & Maintenance Parts

Flange

Model : IX-FL-4
This flange is used to install a load to the Z-axis shaft of the IX-NNN1205/1505/1805 or IX-NNC1205/1505/1805 (weight: 12 g).

Z-Axis Brake

Option code: B
See note *1) above.

Cable Joint Connector

Option code: JY
See note *2) above.

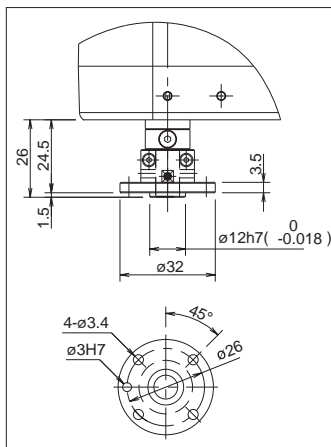

Absolute Reset Adjustment Jig

Model : JG-5 (For arm length of 120/150/180)
This adjustment jig is used when the absolute data in the encoder was lost and an absolute reset must be executed.

Teaching Pendant

Model : SEL-T (Standard, with CE mark)
Model : SEL-TD (With deadman switch, ANSI/UL/CE mark)
Model : IA-T-XA (With ANSI/CE mark)
This teaching device supports program/position input, test operation, monitoring, etc.

* IA-T-XA of version 1.10 or older cannot be used with PX/QX controllers.

Connector-type Cables

Model : CB-XEU-MA030/-MA050
Model : CB-XEU1-PA030/-PA050
(Motor or encoder cable: 3m / 5m)

Absolute Data Backup Battery

Model : AB-6
(For arm length of 120/150/180)
This absolute data backup battery allows the current position to be retained even after the power is turned off.

PC Software

Model : IA-101-X-MW
With a PC connection cable (D-sub, 9-pin on the PC end): For Windows 95, 98, NT, 2000, ME and XP.
A startup support tool offering the functions needed to input programs or positions and perform debugging.

* Version 5.0.1.0 or older programs cannot be used with PX/QX controllers.

IX-NNN1205

Ultra Compact SCARA Robot: Standard Type,
Arm Length 120mm, Vertical Axis 50mm



Type	Standard type	Arm length	120mm	Load capacity	0.2kg rated / 1kg maximum
------	---------------	------------	-------	---------------	---------------------------

Model specification items Series Type Cable Length Applicable controller Options

(Example) IX - NNN1205 - 5L - T2 - B

Models/Specifications

Model	Axis configuration		Arm length (mm)	Motor capacity (W)	Work envelope	Positioning repeatability (mm)	Maximum operating speed (Note 1)	Cycle time (sec) (Note 2)	Load capacity (kg) (Note 3)		Axis 3 Push thrust (N)		Axis 4 Allowable load	
	Axis 1	Axis 2							Rated	Maximum	Push mode (Note 4)	Maximum thrust (Note 4)	Allowable inertial moment (kgm ²) (Note 5)	Allowable torque (Nm)
IX-NNN1205-□-T2-□	Arm 1	45	12	±115°	±0.005 (XY)	2053mm/s (Composite speed)	0.35	0.2	1.0	9.8	17.8	0.000386	0.13	
	Arm 2	75	12	±145°										
	Vertical axis	-	12	50mm	±0.010	720mm/s								
	Rotating axis	-	60	±360°	±0.005	1800°/s								

Common Specifications

Encoder type	Absolute
User wiring	8-core, AWG26 cable with shield / Connector: SMP-08V-NC (JST)
User tubing	Air tube (O.D. ø3, I.D. ø2) x 2 (Normal working pressure 0.7MPa)
Alarm indicator (Note 6)	Small red LED indicator x 1 (24VDC must be supplied.)

Operating temperature/humidity	Temperature 0-40°C, humidity 20-85% RH or less (non-condensing)
Robot weight	2.7 kg
Cable length	3L: 3m 5L: 5m

Dimensions

You can download CAD drawings from IAs website.

2D CAD

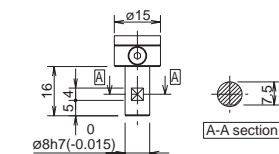

Detail view of vertical axis tip (*3)

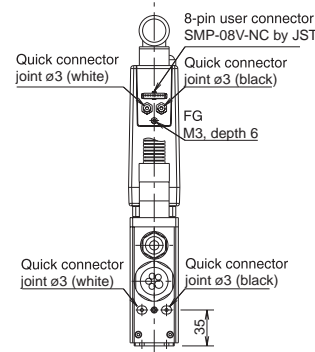
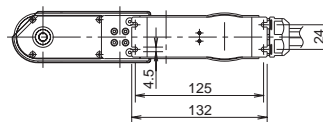
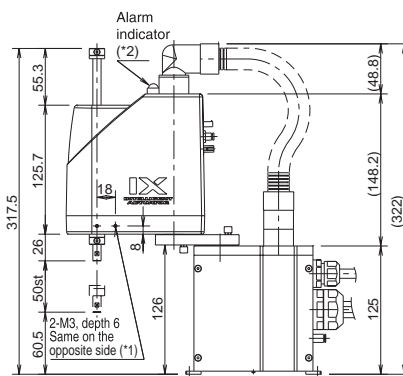
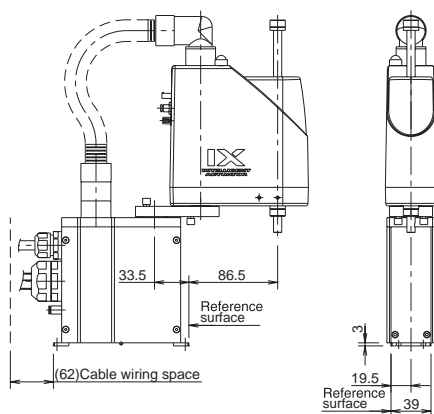
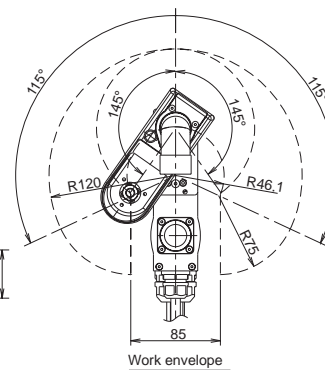
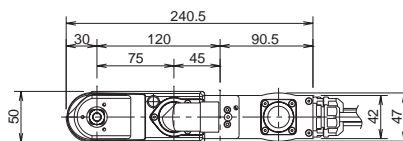

- *1: The 2-M3 hole (depth 6) passes through the arm. If the mounting screw is too long, the screw will contact the internal mechanical parts. Exercise caution.
- *2: To illuminate the alarm indicator, the user must provide a wiring that uses an I/O output signal from the controller to apply 24 VDC to the LED terminal in the user wiring connector.
- *3: The vertical axis does not come with a brake. If the power or servo is turned off, the vertical axis may drop. Exercise caution.

Applicable Controller Specifications

Applicable controller	Feature	Maximum I/O points (input/output)	Power-supply voltage	Page
XSEL-PX	Able to control SCARA + 2 axes	192 points /192 points	Single-/ Three-phase 230VAC	→Back cover
XSEL-QX	Conforming to safety category 4			



Caution

- (Note 1) Based on PTP operation. In CP operation, the maximum speed is limited.
- (Note 2) The cycle time is based on reciprocating movements carrying a 0.2-kg load over a horizontal distance of 100 mm and vertical distance of 25 mm.
- (Note 3) The rated load capacity indicates the maximum weight that can be operated at the maximum speed and acceleration. The maximum load capacity indicates the maximum weight that can be transported at lower speed and acceleration.
- (Note 4) The thrust in the push mode indicates the force generated when a push command is executed from the program. The maximum thrust corresponds to the maximum force generated during normal positioning operation.
- (Note 5) The allowable inertial moment indicates an equivalent value measured at the rotational center of axis 4. The offset between the rotational center of axis 4 and the gravity center of the tool must not exceed 17.5 mm.
- (Note 6) To use the alarm indicator, the user must provide a circuit that uses an I/O output or other signal to apply 24 VDC to the LED terminal in the user wiring connector.

IX-NNN1505

Ultra Compact SCARA Robot: Standard Type,
Arm Length 150mm, Vertical Axis 50mm



Type Standard type Arm length 150mm Load capacity 0.2kg rated / 1kg maximum

Model specification items Series Type Cable Length Applicable controller Options
(Example) IX - NNN1505 - 5L - T2 - B

Models/Specifications

Model	Axis configuration		Arm length (mm)	Motor capacity (W)	Work envelope	Positioning repeatability (mm)	Maximum operating speed (Note 1)	Cycle time (sec) (Note 2)	Load capacity (kg) (Note 3)		Axis 3 Push thrust (N)		Axis 4 Allowable load	
	Axis 1	Axis 2							Rated	Maximum	Push mode (Note 4)	Maximum thrust (Note 4)	Allowable inertial moment (kgm ²) (Note 5)	Allowable torque (Nm)
IX-NNN1505-Q-T2-Q	Axis 1	Arm 1	75	12	±125°	±0.005 (XY)	2304mm/s (Composite speed)	0.35	0.2	1.0	9.8	17.8	0.000386	0.13
	Axis 2	Arm 2	75	12	±145°									
	Axis 3	Vertical axis	-	12	50mm	±0.010	720mm/s							
	Axis 4	Rotating axis	-	60	±360°	±0.005	1800°/s							

Common Specifications

Encoder type	Absolute
User wiring	8-core, AWG26 cable with shield / Connector: SMP-08V-NC (JST)
User tubing	Air tube (O.D. ø3, I.D. ø2) x 2 (Normal working pressure 0.7MPa)
Alarm indicator (Note 6)	Small red LED indicator x 1 (24VDC must be supplied.)

Operating temperature/humidity	Temperature 0-40 °C, humidity 20-85% RH or less (non-condensing)
Robot weight	2.7 kg
Cable length	3L: 3m 5L: 5m

Dimensions

You can download CAD drawings from IAI's website.

2D CAD

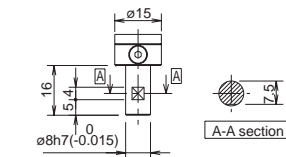

Detail view of vertical axis tip (*3)

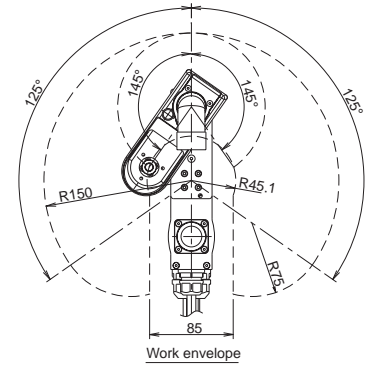
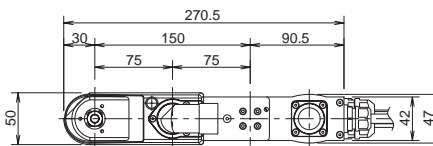

Work envelope

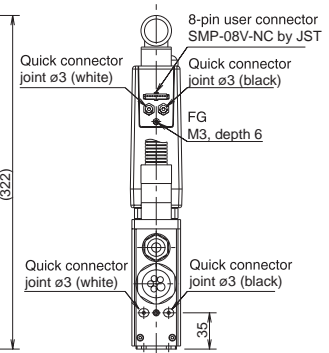
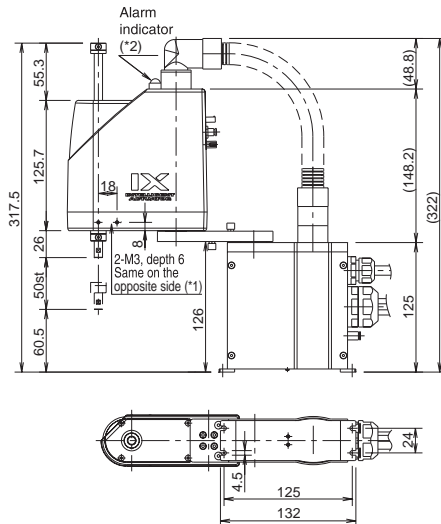
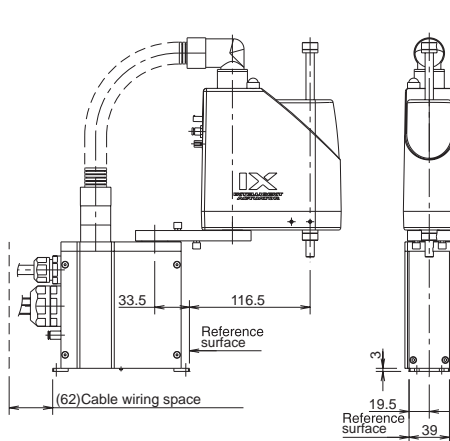

*1: The 2-M3 hole (depth 6) passes through the arm. If the mounting screw is too long, the screw will contact the internal mechanical parts. Exercise caution.
*2: To illuminate the alarm indicator, the user must provide a wiring that uses an I/O output signal from the controller to apply 24 VDC to the LED terminal in the user wiring connector.
*3: The vertical axis does not come with a brake. If the power or servo is turned off, the vertical axis may drop. Exercise caution.

Applicable Controller Specifications

Applicable controller	Feature	Maximum I/O points (input/output)	Power-supply voltage	Page
XSEL-PX	Able to control SCARA + 2 axes	192 points /192 points	Single-/ Three-phase 230VAC	→Back cover
XSEL-QX	Conforming to safety category 4			



(Note 1) Based on PTP operation. In CP operation, the maximum speed is limited.
(Note 2) The cycle time is based on reciprocating movements carrying a 0.2-kg load over a horizontal distance of 100 mm and vertical distance of 25 mm.
(Note 3) The rated load capacity indicates the maximum weight that can be operated at the maximum speed and acceleration. The maximum load capacity indicates the maximum weight that can be transported at lower speed and acceleration.
(Note 4) The thrust in the push mode indicates the force generated when a push command is executed from the program. The maximum thrust corresponds to the maximum force generated during normal positioning operation.
(Note 5) The allowable inertial moment indicates an equivalent value measured at the rotational center of axis 4. The offset between the rotational center of axis 4 and the gravity center of the tool must not exceed 17.5 mm.
(Note 6) To use the alarm indicator, the user must provide a circuit that uses an I/O output or other signal to apply 24 VDC to the LED terminal in the user wiring connector.

IX-NNN1805

Ultra Compact SCARA Robot: Standard Type,
Arm Length 180mm, Vertical Axis 50mm



Type	Standard type	Arm length	180mm	Load capacity	0.2kg rated / 1kg maximum
------	---------------	------------	-------	---------------	---------------------------

Model specification items	Series	Type	Cable Length	Applicable controller	Options
(Example)	IX	- NNN1805	- 5L	- T2	- B

Models/Specifications

Model	Axis configuration		Arm length (mm)	Motor capacity (W)	Work envelope	Positioning repeatability (mm)	Maximum operating speed (Note 1)	Cycle time (sec) (Note 2)	Load capacity (kg) (Note 3)		Axis 3 Push thrust (N)		Axis 4 Allowable load	
	Axis 1	Axis 2							Rated	Maximum	Push mode (Note 4)	Maximum thrust (Note 4)	Allowable inertial moment (kgm ²) (Note 5)	Allowable torque (Nm)
IX-NNN1805-□-T2-□	Arm 1	Arm 2	105	12	±125°	±0.005 (XY)	2555mm/s (Composite speed)	0.38	0.2	1.0	9.8	17.8	0.000386	0.13
	Axis 2	Arm 2	75	12	±145°									
	Axis 3	Vertical axis	-	12	50mm	±0.010	720mm/s							
	Axis 4	Rotating axis	-	60	±360°	±0.005	1800°/s							

Common Specifications

Encoder type	Absolute
User wiring	8-core, AWG26 cable with shield / Connector: SMP-08V-NC (JST)
User tubing	Air tube (O.D. ø3, I.D. ø2) x 2 (Normal working pressure 0.7MPa)
Alarm indicator (Note 6)	Small red LED indicator x 1 (24VDC must be supplied.)

Operating temperature/humidity	Temperature 0-40°C, humidity 20-85% RH or less (non-condensing)
Robot weight	3.0 kg
Cable length	3L: 3m 5L: 5m

Dimensions

You can download CAD drawings from IAI's website.

2D CAD

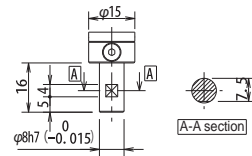

Detail view of vertical axis tip (*3)

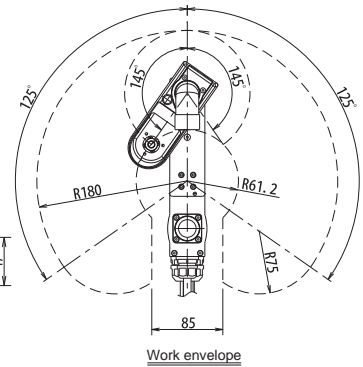
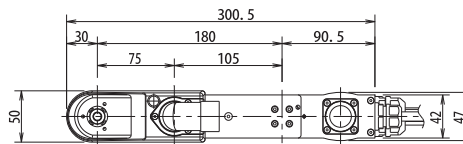

Work envelope

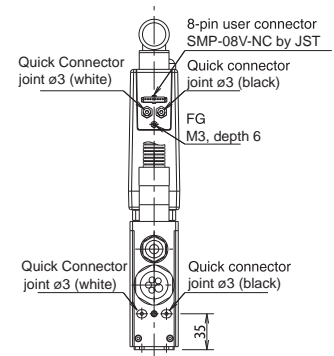
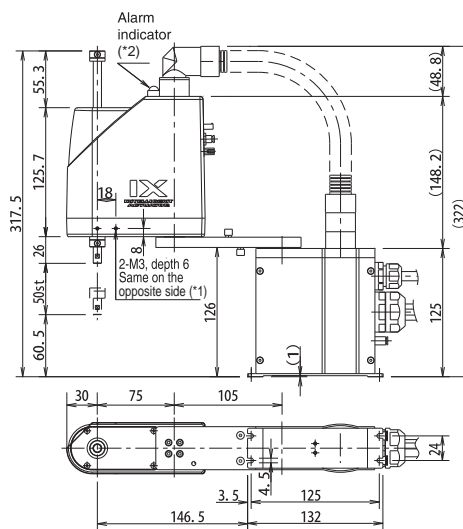
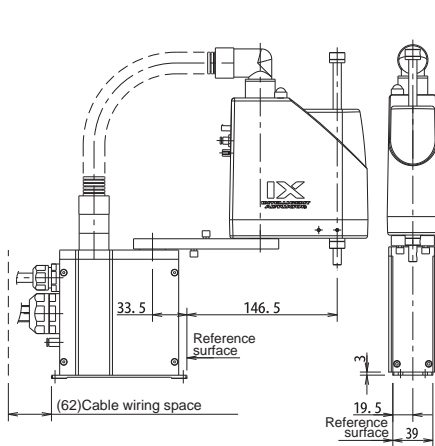

- *1: The 2-M3 hole (depth 6) passes through the arm. If the mounting screw is too long, the screw will contact the internal mechanical parts. Exercise caution.
- *2: To illuminate the alarm indicator, the user must provide a wiring that uses an I/O output signal from the controller to apply 24 VDC to the LED terminal in the user wiring connector.
- *3: The vertical axis does not come with a brake. If the power or servo is turned off, the vertical axis may drop. Exercise caution.

Applicable Controller Specifications

Applicable controller	Feature	Maximum I/O points (input/output)	Power-supply voltage	Page
XSEL-PX	Able to control SCARA + 2 axes	192 points /192 points	Single-/ Three-phase 230VAC	→Back cover
XSEL-QX	Conforming to safety category 4			



Caution

- (Note 1) Based on PTP operation. In CP operation, the maximum speed is limited.
- (Note 2) The cycle time is based on reciprocating movements carrying a 0.2-kg load over a horizontal distance of 100 mm and vertical distance of 25 mm.
- (Note 3) The rated load capacity indicates the maximum weight that can be operated at the maximum speed and acceleration. The maximum load capacity indicates the maximum weight that can be transported at lower speed and acceleration.
- (Note 4) The thrust in the push mode indicates the force generated when a push command is executed from the program. The maximum thrust corresponds to the maximum force generated during normal positioning operation.
- (Note 5) The allowable inertial moment indicates an equivalent value measured at the rotational center of axis 4. The offset between the rotational center of axis 4 and the gravity center of the tool must not exceed 17.5 mm.
- (Note 6) To use the alarm indicator, the user must provide a circuit that uses an I/O output or other signal to apply 24 VDC to the LED terminal in the user wiring connector.

IX-NNC1205

Ultra Compact SCARA Robot: Clean Room Type
Arm Length 120mm, Vertical Axis 50mm



Type Clean room type Arm length 120mm Load capacity 0.2kg rated / 1kg maximum

Model specification items Series Type Cable Length Applicable controller Options
(Example) IX - NNC1205 - 5L - T2 - B

Models/Specifications

Model	Axis configuration		Arm length (mm)	Motor capacity (W)	Work envelope	Positioning repeatability (mm)	Maximum operating speed (Note 1)	Cycle time (sec) (Note 2)	Load capacity (kg) (Note 3)		Axis 3 Push thrust (N)		Axis 4 Allowable load	
	Axis 1	Axis 2							Rated	Maximum	Push mode (Note 4)	Maximum thrust (Note 4)	Allowable inertial moment (kgm ²) (Note 5)	Allowable torque (Nm)
IX-NNC1205-Q-T2-Q	Axis 1	Arm 1	45	12	±115°	±0.005 (XY)	2053mm/ s (Composite speed)	0.38	0.2	1.0	9.8	17.8	0.000386	0.13
	Axis 2	Arm 2	75	12	±130°									
	Axis 3	Vertical axis	-	12	50mm	±0.010	720mm/ s							
	Axis 4	Rotating axis	-	60	±360°	±0.005	1800°/ s							

Common Specifications

Encoder type	Absolute
User wiring	8-core, AWG26 cable with shield / Connector: SMP-08V-NC (JST)
User tubing	Air tube (O.D. ø3, I.D. ø2) x 2 (Normal working pressure 0.7MPa)
Alarm indicator (Note 6)	Small red LED indicator x 1 (24VDC must be supplied.)
Vacuum point	Applicable tube O.D. at ø6

Suction rate	90 N liter/ min
Cleanliness class	Conforming to ISO class 4 (0.1 µm)
Operating temperature/humidity	Temperature 0-40 °C, humidity 20-85% RH or less (non-condensing)
Robot weight	2.7 kg
Cable length	3L: 3m 5L: 5m

Dimensions

You can download CAD drawings from IAI's website.

2D CAD

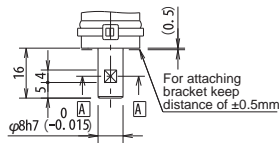

Detail view of vertical axis tip (*3)

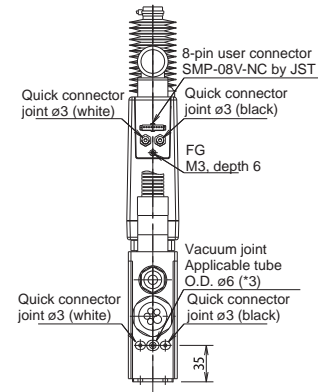
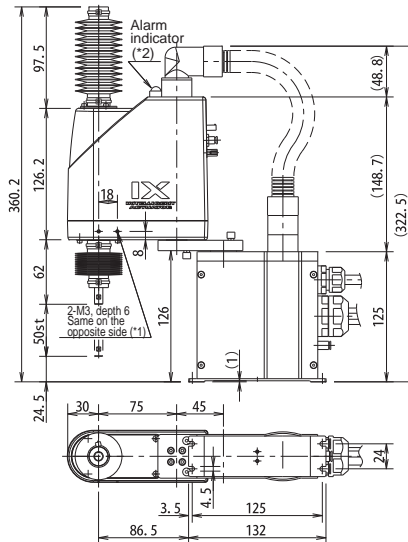
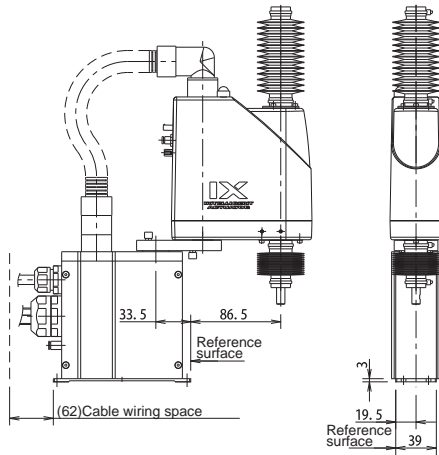
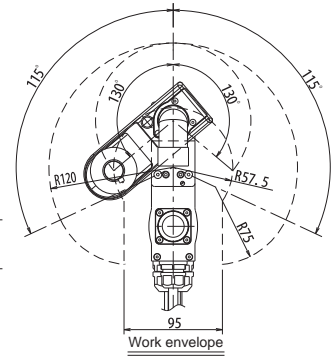
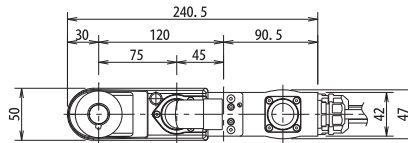
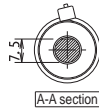

*1: It is covered with mounting screw. The 2-M3 hole (depth 6) passes through the arm. If the mounting screw is too long, the screw will contact the internal mechanical parts. Exercise caution.
*2: To illuminate the alarm indicator, the user must provide a wiring that uses an I/O output signal from the controller to apply 24 VDC to the LED terminal in the user wiring connector.
*3: It functions as "clean room type" when it is vacuumed from vacuum point. Without vacuum dust leaks from inside.

Applicable Controller Specifications

Applicable controller	Feature	Maximum I/O points (input/output)	Power-supply voltage	Page
XSEL-PX	Able to control SCARA + 2 axes	192 points /192 points	Single-/ Three-phase 230VAC	→Back cover
XSEL-QX	Conforming to safety category 4			



(Note 1) Based on PTP operation. In CP operation, the maximum speed is limited.
(Note 2) The cycle time is based on reciprocating movements carrying a 0.2-kg load over a horizontal distance of 100 mm and vertical distance of 25 mm.
(Note 3) The rated load capacity indicates the maximum weight that can be operated at the maximum speed and acceleration. The maximum load capacity indicates the maximum weight that can be transported at lower speed and acceleration.
(Note 4) The thrust in the push mode indicates the force generated when a push command is executed from the program. The maximum thrust corresponds to the maximum force generated during normal positioning operation.
(Note 5) The allowable inertial moment indicates an equivalent value measured at the rotational center of axis 4. The offset between the rotational center of axis 4 and the gravity center of the tool must not exceed 17.5 mm.
(Note 6) To use the alarm indicator, the user must provide a circuit that uses an I/O output or other signal to apply 24 VDC to the LED terminal in the user wiring connector.

IX-NNC1505

Ultra Compact SCARA Robot: Clean Room Type
Arm Length 150mm, Vertical Axis 50mm

Type Clean room type Arm length 150mm Load capacity 0.2kg rated / 1kg maximum



Model specification items Series Type Cable Length Applicable controller Options
(Example) IX - NNC1505 - 5L - T2 - B

Models/Specifications

Model	Axis configuration		Arm length (mm)	Motor capacity (W)	Work envelope	Positioning repeatability (mm)	Maximum operating speed (Note 1)	Cycle time (sec) (Note 2)	Load capacity (kg) (Note 3)		Axis 3 Push thrust (N)		Axis 4 Allowable load	
	Axis 1	Axis 2							Rated	Maximum	Push mode (Note 4)	Maximum thrust (Note 4)	Allowable inertial moment (kgm ²)(Note 5)	Allowable torque (Nm)
IX-NNC1505-□-T2-□	Axis 1	Arm 1	75	12	±125°	±0.005 (XY)	2304mm/ s (Composite speed)	0.38	0.2	1.0	9.8	17.8	0.000386	0.13
	Axis 2	Arm 2	75	12	±134°									
	Axis 3	Vertical axis	-	12	50mm	±0.010	720mm/ s							
	Axis 4	Rotating axis	-	60	±360°	±0.005	1800°/ s							

Common Specifications

Encoder type	Absolute
User wiring	8-core, AWG26 cable with shield / Connector: SMP-08V-NC (JST)
User tubing	Air tube (O.D. ø3, I.D. ø2) x 2 (Normal working pressure 0.7MPa)
Alarm indicator (Note 6)	Small red LED indicator x 1 (24VDC must be supplied.)
Vacuum point	Applicable tube O.D. at ø6

Suction rate	90 N liter/ min
Cleanliness class	Conforming to ISO class 4 (0.1 µm)
Operating temperature/humidity	Temperature 0~40 °C, humidity 20~85% RH or less (non-condensing)
Robot weight	2.7 kg
Cable length	3L: 3m 5L: 5m

Dimensions

You can download CAD drawings from IAIs website.

2D CAD

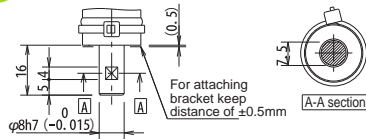

Detail view of vertical axis tip (*3)

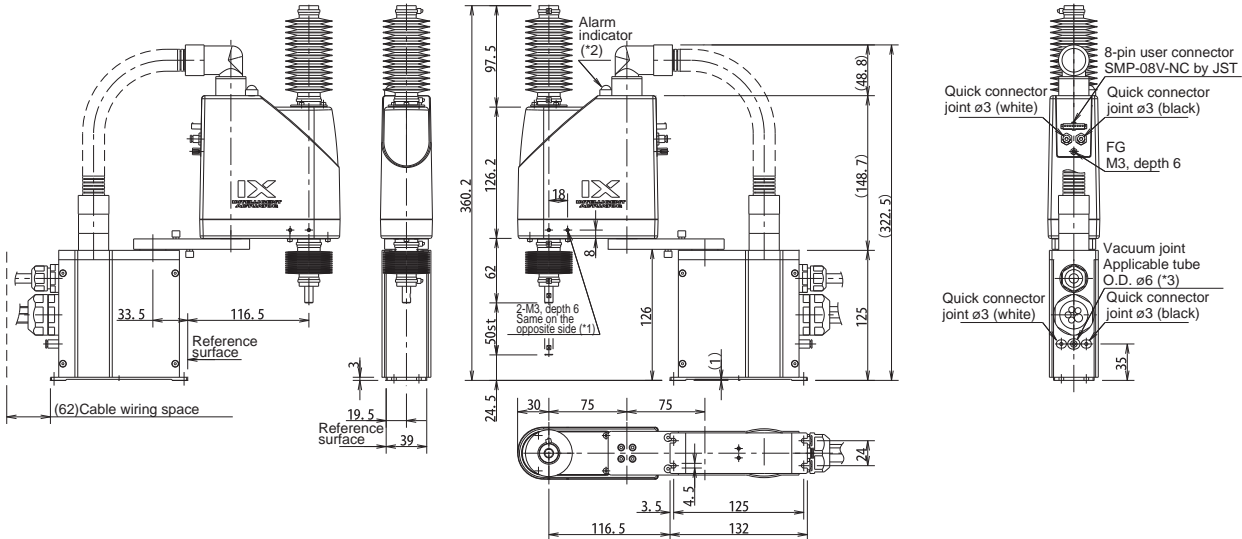
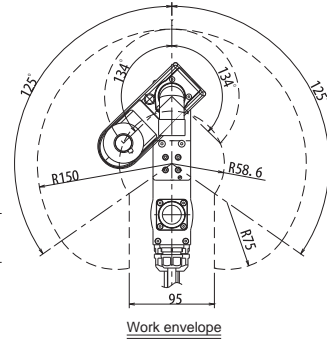
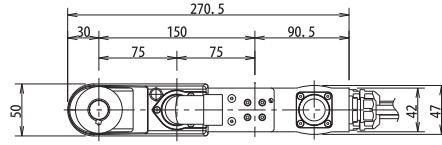

*1: It is covered with mounting screw. The 2-M3 hole (depth 6) passes through the arm. If the mounting screw is too long, the screw will contact the internal mechanical parts. Exercise caution.

*2: To illuminate the alarm indicator, the user must provide a wiring that uses an I/O output signal from the controller to apply 24 VDC to the LED terminal in the user wiring connector.

*3: It functions as "clean room type" when it is vacuumed from vacuum point. Without vacuum dust leaks from inside.

Applicable Controller Specifications

Applicable controller	Feature	Maximum I/O points (input/output)	Power-supply voltage	Page
XSEL-PX	Able to control SCARA + 2 axes	192 points /192 points	Single-/ Three-phase 230VAC	→Back cover
XSEL-QX	Conforming to safety category 4			



(Note 1) Based on PTP operation. In CP operation, the maximum speed is limited.

(Note 2) The cycle time is based on reciprocating movements carrying a 0.2-kg load over a horizontal distance of 100 mm and vertical distance of 25 mm.

(Note 3) The rated load capacity indicates the maximum weight that can be operated at the maximum speed and acceleration. The maximum load capacity indicates the maximum weight that can be transported at lower speed and acceleration.

(Note 4) The thrust in the push mode indicates the force generated when a push command is executed from the program. The maximum thrust corresponds to the maximum force generated during normal positioning operation.

(Note 5) The allowable inertial moment indicates an equivalent value measured at the rotational center of axis 4. The offset between the rotational center of axis 4 and the gravity center of the tool must not exceed 17.5 mm.

(Note 6) To use the alarm indicator, the user must provide a circuit that uses an I/O output or other signal to apply 24 VDC to the LED terminal in the user wiring connector.

IX-NNC1805

Ultra Compact SCARA Robot: Clean Room Type
Arm Length 180mm, Vertical Axis 50mm



Type Clean room type Arm length 180mm Load capacity 0.2kg rated / 1kg maximum

Model specification items Series Type Cable Length Applicable controller Options
(Example) IX - NNC1805 - 5L - T2 - B

Models/Specifications

Model	Axis configuration		Arm length (mm)	Motor capacity (W)	Work envelope	Positioning repeatability (mm)	Maximum operating speed (Note 1)	Cycle time (sec) (Note 2)	Load capacity (kg) (Note 3)		Axis 3 Push thrust (N)		Axis 4 Allowable load	
	Axis 1	Axis 2							Rated	Maximum	Push mode (Note 4)	Maximum thrust (Note 4)	Allowable inertial moment (kgm ²) (Note 5)	Allowable torque (Nm)
IX-NNC1805-□-T2-□	Arm 1	Arm 2	105	12	±125°	±0.005 (XY)	2555mm/s (Composite speed)	0.41	0.2	1.0	9.8	17.8	0.000386	0.13
	Axis 2	Arm 2	75	12	±145°									
	Axis 3	Vertical axis	-	12	50mm	±0.010	720mm/s							
	Axis 4	Rotating axis	-	60	±360°	±0.005	1800°/s							

Common Specifications

Encoder type	Absolute	Suction rate	90 N liter/ min
User wiring	8-core, AWG26 cable with shield / Connector: SMP-08V-NC (JST)	Cleanliness class	Conforming to ISO class 4 (0.1 μm)
User tubing	Air tube (O.D. ø3, I.D. ø2) x 2 (Normal working pressure 0.7MPa)	Operating temperature/humidity	Temperature 0-40 °C, humidity 20-85% RH or less (non-condensing)
Alarm indicator (Note 6)	Small red LED indicator x 1 (24VDC must be supplied.)	Robot weight	2.7 kg
Vacuum point	Applicable tube O.D. at ø6	Cable length	3L: 3m 5L: 5m

Dimensions

You can download CAD drawings from IAIs website.

2D CAD

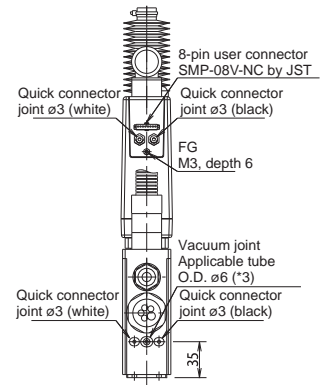
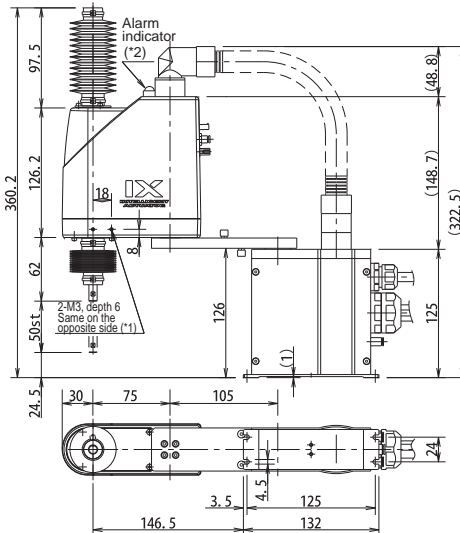
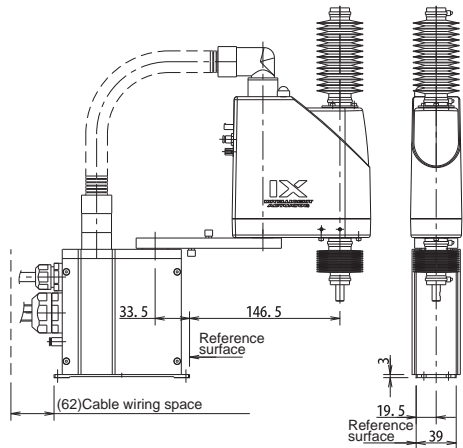
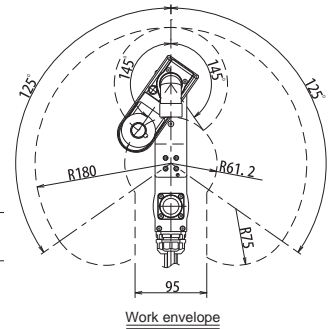
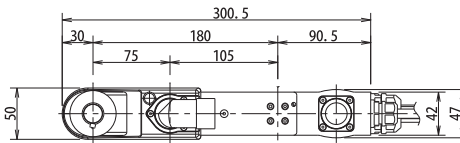
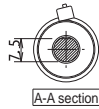
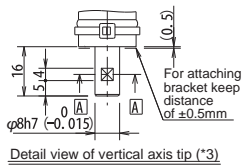

*1: It is covered with mounting screw. The 2-M3 hole (depth 6) passes through the arm. If the mounting screw is too long, the screw will contact the internal mechanical parts. Exercise caution.
*2: To illuminate the alarm indicator, the user must provide a wiring that uses an I/O output signal from the controller to apply 24 VDC to the LED terminal in the user wiring connector.
*3: It functions as "clean room type" when it is vacuumed from vacuum point. Without vacuum dust leaks from inside.

Applicable Controller Specifications

Applicable controller	Feature	Maximum I/O points (input/output)	Power-supply voltage	Page
XSEL-PX	Able to control SCARA + 2 axes	192 points /192 points	Single-/ Three-phase 230VAC	→Back cover
XSEL-QX	Conforming to safety category 4			



(Note 1) Based on PTP operation. In CP operation, the maximum speed is limited.
(Note 2) The cycle time is based on reciprocating movements carrying a 0.2-kg load over a horizontal distance of 100 mm and vertical distance of 25 mm.
(Note 3) The rated load capacity indicates the maximum weight that can be operated at the maximum speed and acceleration. The maximum load capacity indicates the maximum weight that can be transported at lower speed and acceleration.
(Note 4) The thrust in the push mode indicates the force generated when a push command is executed from the program. The maximum thrust corresponds to the maximum force generated during normal positioning operation.
(Note 5) The allowable inertial moment indicates an equivalent value measured at the rotational center of axis 4. The offset between the rotational center of axis 4 and the gravity center of the tool must not exceed 17.5 mm.
(Note 6) To use the alarm indicator, the user must provide a circuit that uses an I/O output or other signal to apply 24 VDC to the LED terminal in the user wiring connector.

Controller XSEL-PX/QX

Features

Capable of controlling a SCARA robot and up to two single-axis robots

The XSEL-PX/QX performs complex controls with ease, such as controlling a SCARA robot simultaneously with a single-axis robot assembled underneath, or operating a SCARA robot and two-axis cartesian robot at the same time.

Ultra compact size

Despite being a 6-axis controller, the XSEL-PX/QX 1.6 kW type comes in a slim body (W: 340 mm, H: 195 mm, D: 125.3 mm, including absolute battery / brake unit). These dimensions correspond to the size of IAI's 4-axis or smaller controller.

Direct connection to DeviceNet, CC-Link, ProfiBus or Ethernet

The XSEL-PX/QX can be directly connected to various field networks to perform centralized data control or exchange of signals with the various devices connected to the network.



Controller type

XSEL – QX6 – NNN1205 – 200A – 100A – PR – P1 – EEE – 2 – 2

Series	Controller type	Motor output of axis 5	Network support	Expansion I/O	Power-supply voltage
XSEL	PX4 : Large-capacity standard 4-axis type PX5 : Large-capacity standard 5-axis type PX6 : Large-capacity standard 6-axis type QX4 : Large-capacity global 4-axis type conforming to safety category 4 QX5 : Large-capacity global 5-axis type conforming to safety category 4 QX6 : Large-capacity global 6-axis type conforming to safety category 4	20A~750AL : 20W~750 W, absolute 20I~750IL : 20W~750 W, incremental (Blank) : No single axis * Axis 5 can be used only when a 5-axis or 6-axis controller is used.	DV : DeviceNet CC : CC-Link PR : ProfiBus ET : Ethernet (Blank) : No network support	EEE : Not installed * Refer to the separate controller brochure to use I/O boards for the expansion slots (slot 2 to 4).	2 : Single-phase 230VAC 3 : Three-phase 230VAC
		IX actuator type NNN1205 : Standard type Arm length 120 mm, Z-Axis 50 mm NNN1505 : Standard type Arm length 150 mm, Z-Axis 50 mm NNN1805 : Standard type Arm length 180 mm, Z-Axis 50 mm NNC1205 : Clean Room type Arm length 120 mm, Z-Axis 50 mm NNC1505 : Clean Room type Arm length 150 mm, Z-Axis 50 mm NNC1805 : Clean Room type Arm length 180 mm, Z-Axis 50 mm	Motor output of axis 6 20A~750AL : 20W~750 W, absolute 20I~750IL : 20W~750 W, incremental (Blank) : No single axis * Axis 6 can be used only when a 6-axis controller is used.	Standard I/O N1 : 32 input / 16 output points (NPN specification) N2 : 16 input / 32 output points (NPN specification) P1 : 32 input / 16 output points (PNP specification) P2 : 16 input / 32 output points (PNP specification) E : Not installed	I/O flat cable length 2 : 2m 3 : 3m 5 : 5m 0 : Not supplied

Specifications

Item	SCARA large-capacity controller specification	
	PX4/QX4	PX5/PX6/QX5/QX6
Controller Type	SCARA only	SCARA + single-axis robot
Connectable axes	SCARA only	SCARA + single-axis robot
Total output when maximum number of axes are connected	1.6 kW/single-phase or 2.4 kW/three-phase	
Control power input	200/230VAC, single-phase, -15%, +10%	
Motor power input	200/230VAC, single-/three-phase, -10%, +10%	
Power capacity (*1)	310VA	3350VA
Safety circuit configuration	Redundant configuration not supported	
Drive-source cutoff method	External safety circuit	
Enable input	(external power supply type, redundant)	
Position detection method	Incremental encoder / absolute encoder	
Speed setting (*2)	1mm/ sec ~ 2000mm/ sec	
Acceleration/deceleration setting (*2)	0.01G ~ 1G	
Programming language	Super SEL Language	
Number of program steps	9999 steps (total)	
Number of positions	20000 positions (total)	
Number of programs (multitasking)	128 programs (16 programs)	
Operating temperature / humidity	0~40 °C, 10~95% (non-condensing)	
Controller weight (*3)	4.5-5.2 kg	5.0-5.7 kg

*1 For the PX4/QX4, the value indicates the power capacity when one IX-NNN1205/1505/1805 is operated. For the PX5/PX6/QX5/QX6 types, the value indicates the power capacity when one IX-NNN1205/1505/1805 and two 750-watt axes are operated.
 *2 The maximum limit varies depending on the actuator type.
 *3 The controller weight includes the absolute battery, brake mechanism and expansion I/O box.

External Dimensions

* The dimensions below do not include expansion I/Os. Please contact IAI should you require expansion I/Os.

