

2CS3EIP Series

Dual-axis EtherNet/IP Closed Loop Stepper Drive

User Manual

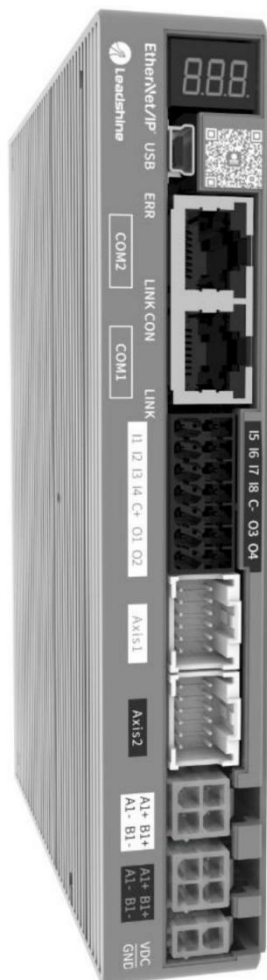

For models of 2CS3EIP-D503, 2CS3EIP-D507

©2020 Leadshine Technology Co., Ltd.

Address: 15-20/F, Block B, Nanshan I Valley, No.3185, Shahe West Road, Nanshan District,
Shenzhen, Guangdong, 518055, China

Tel: (86)755-26409254

Fax: (86)755-26402718

Web: www.leadshine.com

Sales: sales@leadshine.com

Support: tech@leadshine.com

Notice

Read this manual carefully before any assembling and using. Incorrect handling of products in this manual can result in injury and damage to persons and machinery. Strictly adhere to the technical information regarding installation requirements.

This manual is not for use or disclosure outside of Leadshine except under permission. All rights are reserved. No part of this manual shall be reproduced, stored in retrieval form, or transmitted by any means, electronic, mechanical, photocopying, recording, or otherwise without approval from Leadshine. While every precaution has been taken in the preparation of the book, Leadshine assumes no responsibility for errors or omissions. Neither is any liability assumed for damages resulting from the use of the information contained herein.

This document is proprietary information of Leadshine that is furnished for customer use ONLY. Information in this document is subject to change without notice and does not represent a commitment on the part of Leadshine. Therefore, information contained in this manual may be updated from time-to-time due to product improvements, etc., and may not conform in every respect to former issues.

- ◆ **Thank you for purchasing Leadshine 2CS3EIP Series Products**
- ◆ **Please read this manual carefully before operating**
- ◆ **Please keep this manual appropriately**

Record of Revisions

Manual Reversion	Data	Description of Release
V1.0	08/26/2022	Initial Release
V1.1	08/25/2023	Add the description of STO function, refer to section 3.3.8
V1.2	01/20/2026	Change Micro USB to Mini USB

Safety Precautions

Overall Notes



- Do not remove the housing with the drive powered on. Cables, connectors and optional equipment.
- Please disconnect the power supply for at least 2 minutes and make sure the power indicator is off before wiring and checking. Even if the power is disconnected, voltage may remain inside the drive. Therefore, do not touch the power terminals while the power indicator is on.



- Please use the power supply specifications (number of phases.) that match the product. Voltage. Frequency. AC/DC).
- Be sure to connect the ground terminal of the driver (mounting surface) and motor to the ground pole.
- Do not damage or drag the cable, do not overstress the cable, do not hang heavy objects on the cable, or get caught in the cabinet door.
- Please do not disassemble the product yourself. Repair or modification.
- When the machine is connected to the machine and starts to operate, make sure that the machine is ready for emergency stop.
- Do not touch the inside of the drive.



- The heat sink of the driver may be hot when the power is on or when the power is just cut off. The motor, etc. may be in a high temperature. Take safety measures such as installing a cover to prevent accidental touching by hands and parts (cables, etc.).
- Use double-insulated or reinforced insulation for control power.
- Do not use in places where water can be splashed. Corrosive environments. Do not use the product in the vicinity of flammable gases and combustible materials.
- Do not use damaged. Drivers and motors with missing parts.
- Please set up an emergency stop circuit externally to ensure that the power can be cut off and the operation can be stopped immediately in case of an abnormality.
- If the product is used under poor power conditions, install protection equipment (AC reactor, etc.) to ensure that the input power is supplied within the specified voltage variation range.
- Please use a noise filter to reduce the influence of electromagnetic interference.
- The driver and motor should be used in the specified combination.

Precautions for Storage and Transportation



- Please follow the Commands on the packaging for storage and do not overload the product.
- Please place this product in the following environment:
 - No direct sunlight in the place.
 - Ambient temperature does not exceed the product specification.
 - Humidity does not exceed product specifications. Without condensation.
 - No corrosive gases. Place of flammable gas.
 - Dust. The place where there is less salt and metal powder.
 - No water, Oil. The place where the splash of medicine, etc. occurs.
 - Vibration or shock does not exceed product specifications.
 - No equipment generating strong magnetic fields in the vicinity.

Precautions for Installation



- Please install the drive in a cabinet that provides fire protection. Electrical protection in the control cabinet.
- Please install the driver and motor in a position with sufficient weight resistance.
- Please install this product in the following environment:
 - No direct sunlight in the place.
 - Ambient temperature does not exceed the product specification.
 - Humidity does not exceed product specifications. Without condensation.
 - No corrosive gases. Place of flammable gas.
 - Dust. The place where there is less salt and metal powder.
 - No water, Oil. The place where the splash of medicine, etc. occurs.
 - Vibration or shock does not exceed product specifications.
 - No equipment generating strong magnetic fields in the vicinity.
- Do not block the air inlet and exhaust ports, and do not allow foreign objects to enter the drive and motor.
- Do not step on the product or place heavy objects on the drive.
- Please install the driver in the specified direction.
- Make sure to keep the specified intervals between the inner surfaces of the drive control cabinet and other machines.

Precautions for Wiring



- Do not pass the magnetic contactor in the wiring between the drive and the motor.
- Please connect the power terminal and motor terminal firmly.
- Keep a minimum distance of 10mm between the drive and the control cabinet or other equipment.
- Allow at least 30mm of wiring space above and below the driver.
- Signal cable. The encoder cable should be a twisted shielded cable with the shield grounded at both ends.
- The wiring length of the encoder is up to 20m.
- Reduce the frequency of power on/off as much as possible.

Precautions during operation



- To prevent accidents, perform a test run of the servo motor at no load (without the driver connected).
- When you install the machine and start operation, please set the user parameters in advance to match the machine.
- Positive limit (POT) during JOG operation and zero return operation. The signal of negative limit (NOT) is not valid.
- When using the motor on a vertical axis, please provide a safety device to avoid dropping the work-piece in case of alarm or over travel.
- When an alarm occurs, please reset it after investigating the cause and making sure it is safe.
- Do not use the brake of the holding motor for normal braking.

Table of Contents

Safety Precautions	- 2 -
Overall Notes	- 2 -
Precautions for Storage and Transportation	- 2 -
Precautions for Installation	- 3 -
Precautions for Wiring	- 3 -
Precautions during operation	- 3 -
1 Introduction	1
1.1 Product Introduction	1
1.3 EtherNet/IP Compare with Step/Direction	1
1.3.1 Stronger anti-disturbance ability	1
1.3.2 Enhanced performance	1
1.3.3 Simple wiring and long communication distance	1
1.3.4 Lower cost	1
1.4 Check Product	3
1.4.1 Arrival inspection	3
1.4.2 Nameplate information	3
1.4.3 Part number	3
1.4.4 Parts description	4
1.4.5 Accessories Information	4
2 Installation	5
2.1 Storage and Installation Conditions	5
2.1.1 Storage condition	5
2.1.2 Operating ambience conditions	5
2.2 Mechanical Specification	5
2.3 Installation Direction and Space	5
3 Production Specifications	7
3.1 Electrical and Operating Specifications	7
3.2 Wiring Instructions	8
3.2.1 Power Supply Cable & Motor Cable	8
3.2.2 I/O Signal Cable	8
3.2.3 EtherNet/IP Communication Cable	9
3.3 Interface Specifications	10
3.3.1 Connector Definition	10
3.3.2 CN1-Input Power Connector	11
3.3.3 CN2-Motor Connector	11
3.3.4 CN3-Encoder Input Signals Connector	11
3.3.5 CN4-I/O Signals Connector	12
3.3.6 CN5-EtherNet/IP Communication Connector	13
3.3.7 Mini USB Tuning Port	13
3.3.8 STO Port	14
3.3.9 Salve ID (Site Alias) Setting	14
3.3.10 Three 7-Segment	15
3.4 I/O Interface and Corresponding Parameters Setting	15
3.4.1 Digital Input	15
3.4.2 Digital Output	15
3.4.3 Brake Output	16
4 EtherNet/IP Object Dictionary	17
4.1 Communication Object	17
4.2 Manufacture Specific Object	20
4.3 I/O Configuration Object	23
4.3.1 Input Ports Function Value	23
4.3.2 Input Ports Filter Time & Polarity Value	24
4.3.3 Output Ports Function & Polarity Value	24
4.3.4 Main Control Output Function	25

4.4 Motion Objects	25
4.5 XML File or ESI File	27
5 Two 7-Segment and Error Code	28
5.1 Two 7-Segment	28
5.1.1 Initialization Status	28
5.1.2 Operational Status	28
5.2 Error Code	28
5.3 Alarm Clearing	30
6 Common Functions	31
6.1 Saving Parameters and Resetting Drive	31
6.2 Control Word and Operation Modes	31
6.3 Touch Probe	34
Appendix A: Homing Methods	36
Appendix B: Object Dictionaries	44
Appendix C: Connectors	51

Leadshine



1 Introduction

1.1 Product Introduction

2CS3EIP series is a 2-in-1 drive product with Ethernet/IP bus communication technology on the basis of high-performance digital stepper drive, also STO optional. Based on Ethernet/IP slave station technology, real-time control and real-time data transmission of the stepper system are realized, so that the communication speed can reach the transmission rate of 100MB/s. It is simple to use, stable and reliable, and excellent in performance. It is widely used in photovoltaic, textile, civil, robot, lithium battery equipment, 3C electronics and other industries.

1.2 Features

- No loss of step, No hunting, No torque reservation
- 100Mbps full-duplex.
- STO optional
- Support operation modes: Profile Position, Profile Velocity, Homing
- 4 configurable digital inputs and 2 optically isolated digital outputs for each axis
- Low noise and vibration, smooth motion
- USB port for parameters configuration
- Two 7-segment display velocity or slave ID or operation mode or error code
- Protections for over voltage, over current and position following error, encoder cable error, etc.

1.3 EtherNet/IP Compare with Step/Direction

1.3.1 Stronger anti-disturbance ability

Traditional step/direction transmission cables have lower reliability for the reason of EMC interference, whereas EtherNet/IP communication with shielded cables have stronger anti-interference ability, and inbuilt error detection. Limit and handling mechanisms can also bring more reliable transmission and longer communication distance.

1.3.2 Enhanced performance

EtherNet/IP is the fastest industrial Ethernet technology by and large, and it also synchronizes with nanosecond accuracy. This is a huge benefit for all applications in which target system is controlled or measured via the bus system.

1.3.3 Simple wiring and long communication distance

In step/direction control mode, the controller/PLC needs to connect with each drive to send control signals, which may lead to intensive signal cables and wiring complexity if many drives are required. While in EtherNet/IP applications, the controller/PLC just needs to connect with one of the drives and then line topology with others. Additionally, the EtherNet/IP communication allows longer distance up to 100 meters maximum.

1.3.4 Lower cost

EtherNet/IP delivery has the features of industrial Ethernet at a price similar or even below that of traditional control mode. The only hardware required by the master device is an Ethernet port, instead of some expensive interface cards or co-processors. Since EtherNet/IP doesn't require high-speed pulse modules or other active infrastructure components, the costs for these components and their installation, configuration, and maintenance are also eliminated.

Their connection topologies are as below:

Step/direction Topology A (Controller/PLC)

Step/direction Topology B (Control Card)

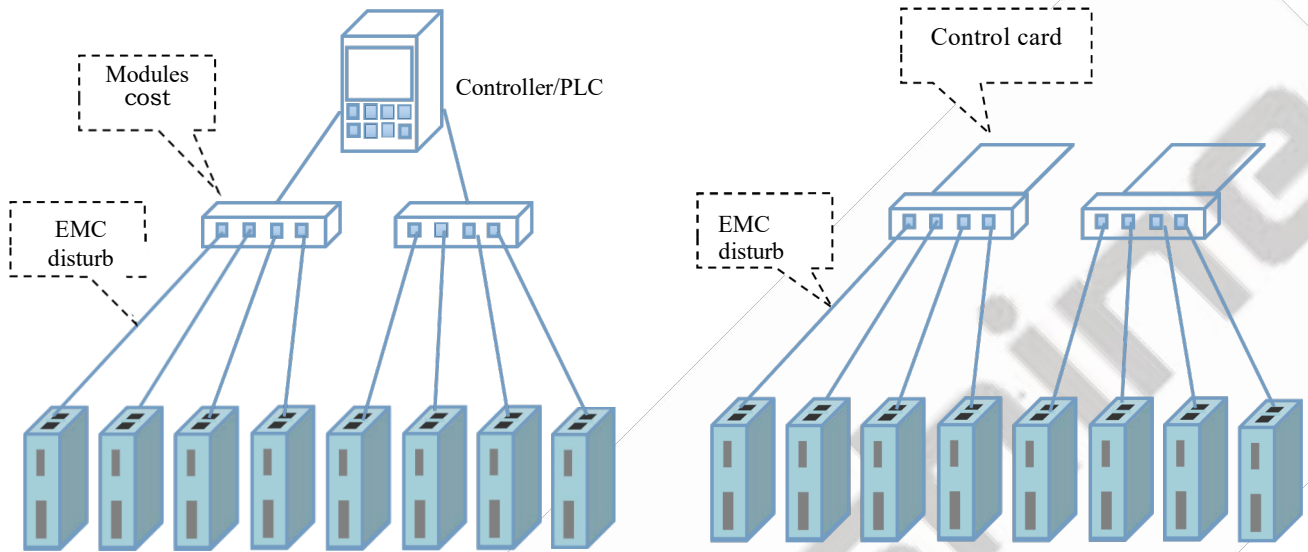

Figure 1.1: Step/direction Topology

EtherNet/IP Topology (Controller/PLC)

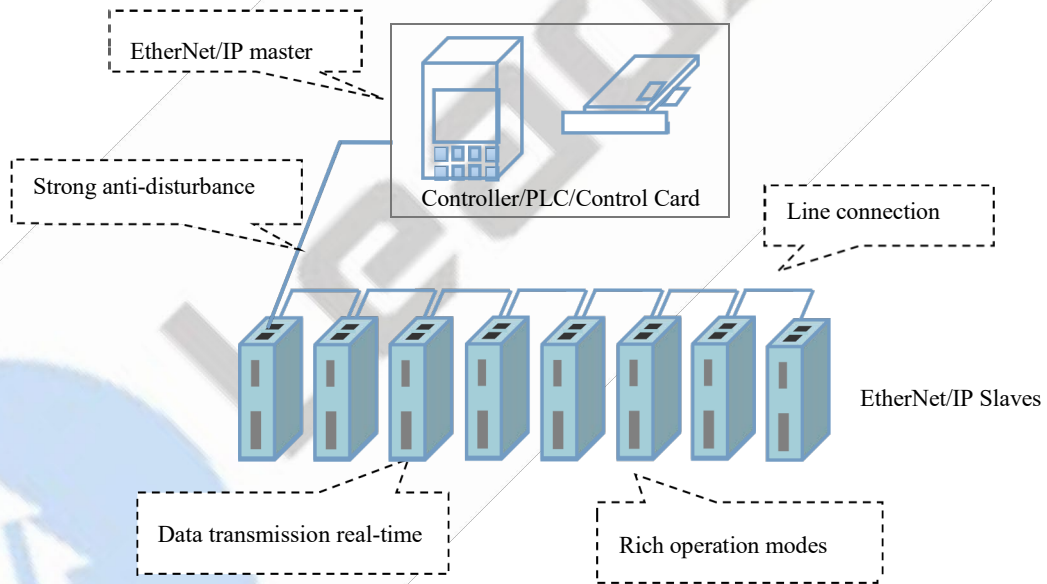

Figure 1.2: EtherNet/IP Topology

1.4 Check Product

1.4.1 Arrival inspection

- Check whether the surface of the product is damaged or not during transportation.
- Check the nameplate models of the drive and motor are what you have ordered.
- Check if it is fully equipped with accessories. Accessories include power supply and motor output connector, control I/O signal connector.

CAUTION



- Neither the damaged nor missing accessories of stepper system is allowed to install.
- Contact Leadshine or local distributor if any failure was found.

1.4.2 Nameplate information

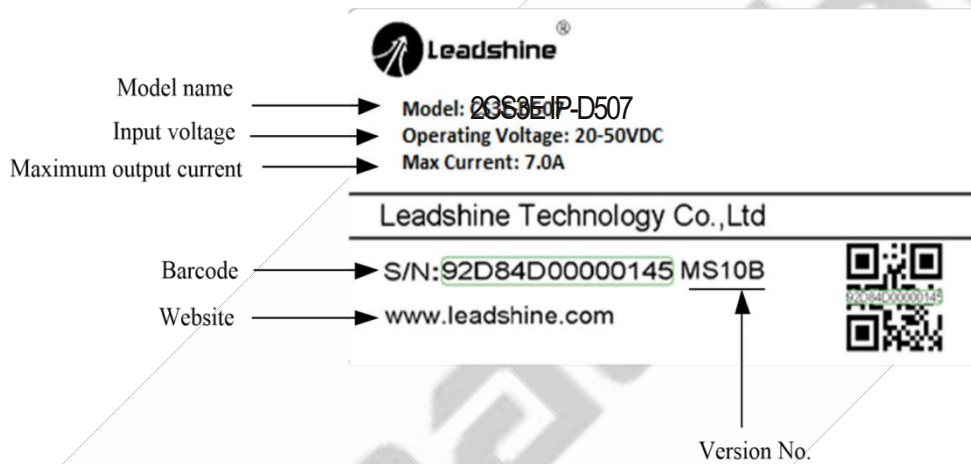

1.4.3 Part number



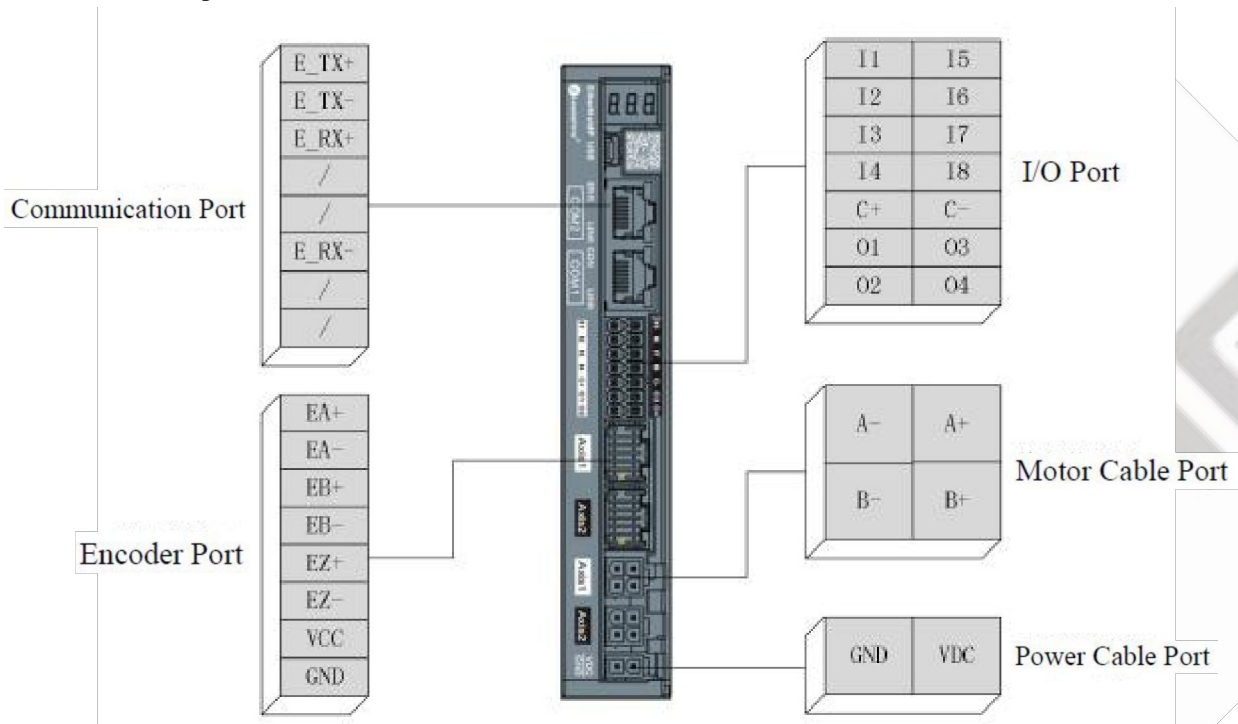

2CS3EIP - D 50 7

- | | | | | |
|---|---------------------------|--|---|---|
| ① | ② | ③ | ④ | ⑤ |
| ① | Series Name | 2CS3: dual-axis closed loop stepper drives | | |
| ② | Communication Mode | EIP: EtherNet/IP communication | | |
| ③ | Product Type | D: Drive | | |
| ④ | Maximum Operating Voltage | 50: 50V | | |
| ⑤ | Maximum Output Current | 3: 2.2A | | |
| | | 7: 7.0A | | |

1.4.4 Parts description

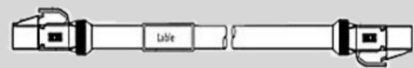

1.4.5 Accessories Information

Name	Necessary	Picture	Description	Need to cost extra
Power supply cable	Yes		Power supply cable with 1.5m length	No
Motor extension cable (CABLEM-RZ*M*)	Yes		Optional length: 1.5m, 3m, 5m, 8m, 10m, 12m, 15m	Yes
Encoder extension cable (CABLEM-BM*M*)	Yes		Optional length: 1.5m, 3m, 5m, 8m, 10m, 12m, 15m	Yes
I/O signal terminal	Yes		22-pin terminal	No
Tuning Cable	No, can use 3 rd party cable		Mini-USB cable	Yes
Network cable	Yes, can use 3 rd party cable		Optional length: 0.1m, 0.2m, 0.3m, 0.4m, 1m, 1.5m, 2m, 3m, 5m, 7m, 10m, 15m, 20m	Yes

Note:

- Mini-USB cable is not necessary; you can also modify parameters by Leadshine Motion Studio software.
- Network cable is necessary, but you can also buy shielded network cable through 3rd party.
- Power supply connector: [39012020](#), [39000038](#), [Molex](#)
- Motor extension cable connector: [39012040](#), [39000038](#), [Molex](#)
- Motor encoder cable connector: [513531200](#), [561349000](#), [Molex](#)

2 Installation

2.1 Storage and Installation Conditions

2.1.1 Storage condition

- Correctly packaged and store in a clean and dry environment where direct sunlight is avoided.
- Store within an ambient temperature ranging from -20°C to $+65^{\circ}\text{C}$.
- Store within a relative humidity ranging from 40% to 90% and non-condensed.
- Avoid any type of exposure to corrosive gases.

2.1.2 Operating ambience conditions

- Temperature ranging from 0°C to 50°C . The ambient temperature of drive for long-term reliability should be under 40°C . Please install the drive in a well-ventilated area.
- Operation within a relative humidity ranging from 40% to 90% and non-condensed.
- Vibration lower than 0.15mm at a frequency of 10Hz-55Hz.

CAUTION



- DO NOT mount the drive and motor in a location subjected to corrosive or flammable gases, and combustibles.
- Please mount the drive and motor in an indoor electric control cabinet without liquid where direct sunlight is avoided.
- DO NOT mount the drive and motor in a location subjected to airborne dust.
- Please ensure grounding wires are securely connected

2.2 Mechanical Specification

Unit: mm, 1inch=25.4mm

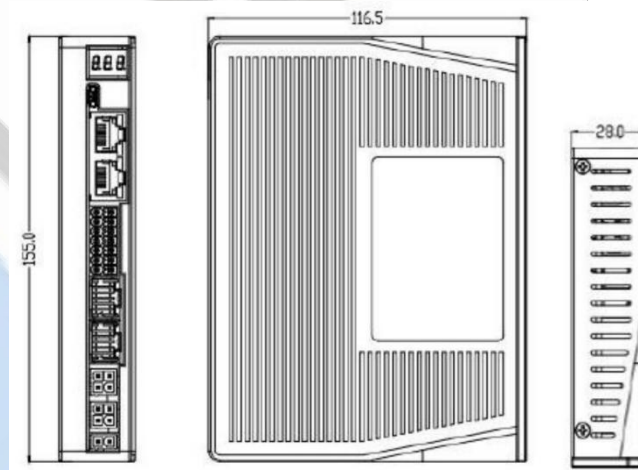

Figure 2.1: 2CS3EIP series mechanical drawing

2.3 Installation Direction and Space

- The mounting of drive, wiring and motor should be under the regulations of EN 61800-5-1.
- Incorrect installation may result in a drive malfunction or premature failure of the drive and /or motor. Please follow the guidelines in this manual when installing
- The drive should be mounted perpendicular to the wall or in the control panel.
- In order to ensure the drive is well ventilated, ensure that the all ventilation holes are not obstructed and sufficient free space is given to the drive, and a cooling fan is mounted in the control panel.

- Please ensure grounding wires are securely connected.

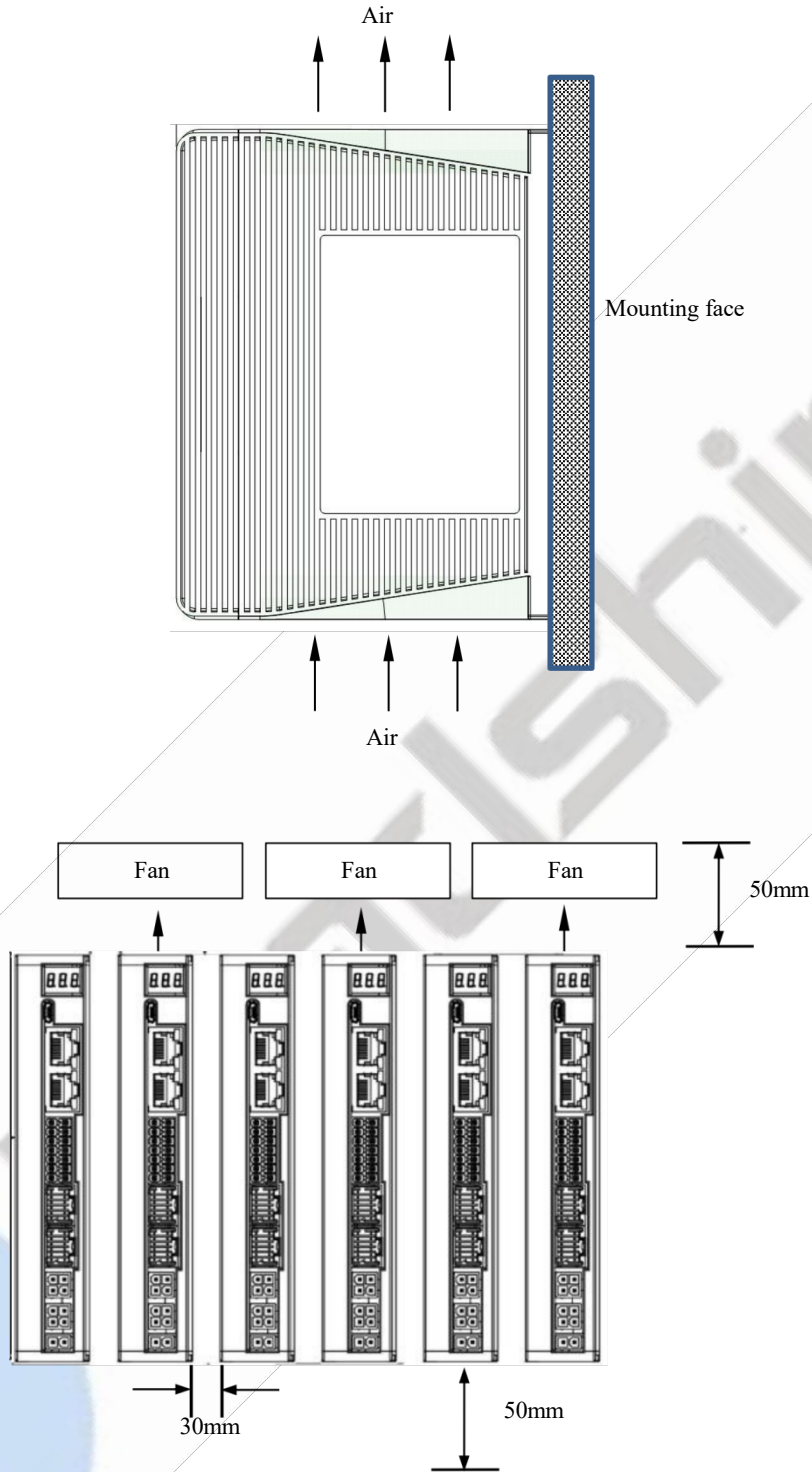

Figure 2.2: 2CS3EIP series installation drawing

3 Production Specifications

3.1 Electrical and Operating Specifications

Name	2CS3EIP-D503	2CS3EIP-D507
Supply Voltage	24-48VDC	24-48VDC
Output Current (Peak)	0.5-2.2A	1.0-7.0A
Matched Motor	NEMA 11, 14, 17	NEMA23, 24
Size (H*W*L mm)	155*116.5*28	
Input Signals	Home Input, Positive Limit, Negative Limit, Touch Probe, GPIOs	
Output Signals	Brake, Alarm, In Position, GPIOs	
Protection Functions	Over Current, Over Voltage, Position Following Error, Encoder Cable Error, etc.	
PC Software	Leadshine Motion Studio	

Operating Environment	Environment	Avoid dust, oil ,fog and corrosive gases
	Operating Temperature	0-50°C (32 F – 122 F)
	Storage Temperature	-20°C -65°C (-4 F – 149 F)
	Humidity	40-90%RH
	Vibration	10-55Hz/0.15mm
	Mount	Vertical or horizontal mounting

3.2 Wiring Instructions

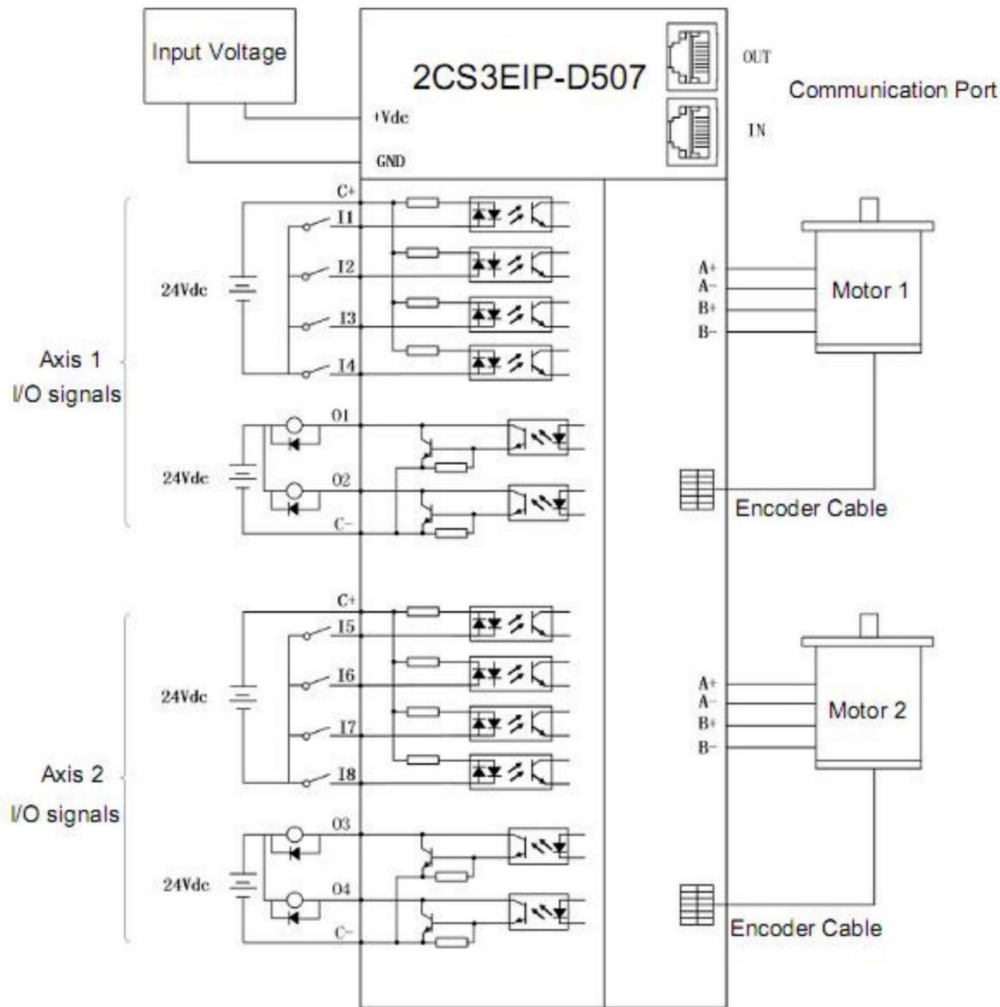

Note:

- There are two EtherNet/IP communication ports above, one of them is input port which connects with master station or previous slave, and the other is output port which connects with the following slave.
- Single-end input I3, I4, I5, I6 and I7 connection types can be common-cathode and common-anode.
- Brake output on the drive can connect with brake outlet on the motor directly.
- Encoder extension cable with Z signal is named: CABLEM-BM*M*Z

3.2.1 Power Supply Cable & Motor Cable

- Wire diameter: +VDC, GND, A+, A-, B+, B- terminal wire diameter $\geq 0.3\text{mm}^2$ (AWG15-22)
- A noise filter which can improve anti-interference performance is recommended to be connected between power supply and drive.

3.2.2 I/O Signal Cable

- Wire diameter: I1 - I7, O1 - O6, COM, 24VB and COM terminal wires diameter $\geq 0.12\text{mm}^2$ (AWG24-26)
- Recommend to adopt shielded twisted pair cable with a length of less than 3 meters (the shorter the better).
- Wiring: As far as possible away from the power line wiring, in order to prevent interference
- Please connect surge absorber to inductive device, such as anti-parallel diode for DC coil, parallel RC-snubbers circuit for AC coil.

3.2.3 EtherNet/IP Communication Cable

It is recommended to use shielded Ethernet network cables that do not exceed 100 meters.

CAUTION



- DO NOT hot plug in and out.
- Be sure to turn off power and wait for at least 5 minutes, and then you can transport, wiring and inspect the drives and motors.

Leadshine



3.3 Interface Specifications

3.3.1 Connector Definition

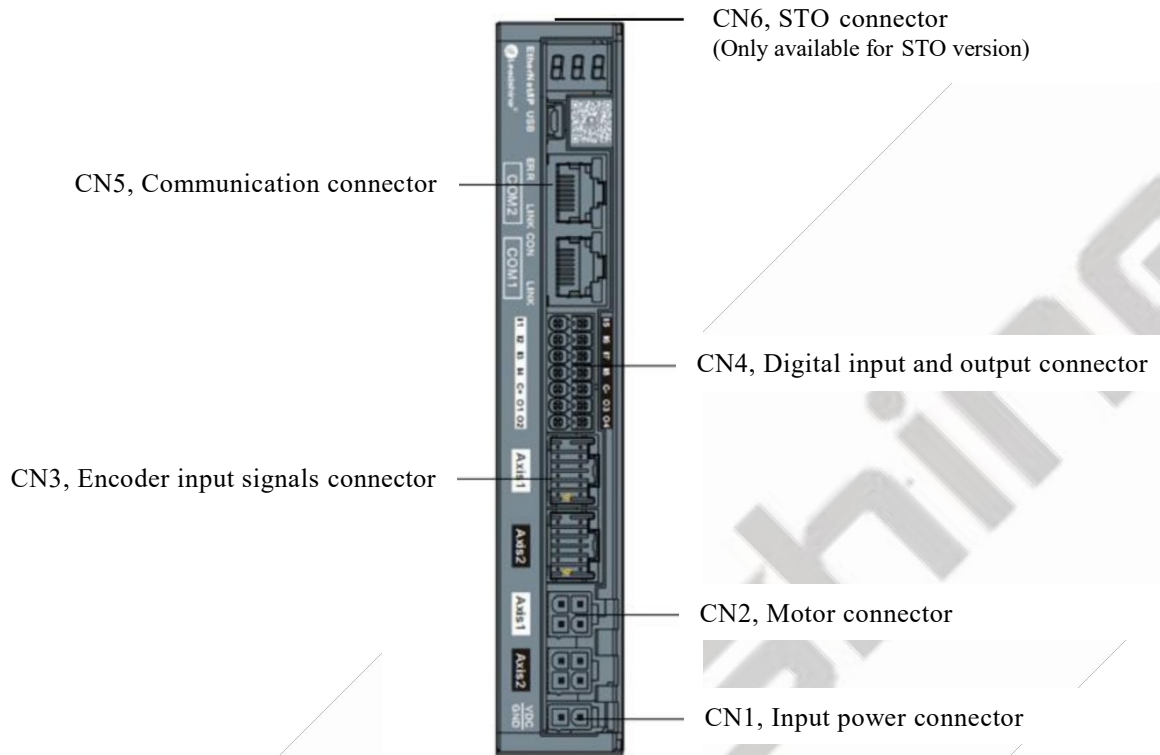
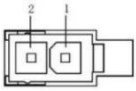

Figure 3.2: 2CS3EIP series connectors

Name	Description
CN1	Input power connector
CN2	Motor connector
CN3	Encoder input signals connector
CN4	Digital input and output connector
CN5	EtherNet/IP communication connector
CN6	STO connector (Only available for STO version)

3.3.2 CN1-Input Power Connector

Name	Pic	PIN	Signal	Description
CN1		1	VDC	24V- 48V
		2	GND	GND

3.3.3 CN2-Motor Connector

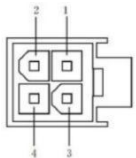
Name	Pic	PIN	Signal	Description
CN2		1	A+	Motor phase A+
		2	A-	Motor phase A-
		3	B+	Motor phase B+
		4	B-	Motor phase B-

3.3.4 CN3-Encoder Input Signals Connector

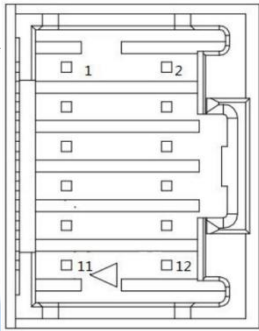
Name	Pic	PIN	Signal	Description
CN3		1	EA+	Encoder A+ signal
		2	EA-	Encoder A- signal
		3	EB+	Encoder B+ signal
		4	EB-	Encoder B- signal
		5	EZ+	Encoder Z+ signal
		6	EZ-	Encoder Z- signal
		7	VCC	Encoder +5V voltage
		8	GND	Encoder ground
		9	U	Reserved
		10	V	Reserved
		11	W	Reserved
		12	PE	Shield ground

3.3.5 CN4-I/O Signals Connector

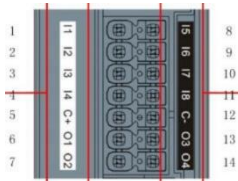
Name	Pic	PIN	Signal	I/O	Description
CN4		1	I1	I-Axis1	Probe (default) configurable, single-ended, 12~24V
		2	I2	I-Axis1	HOME (default) configurable, single-ended, 12~24V
		3	I3	I-Axis1	POT (default) configurable, single-ended, 12~24V
		4	I4	I-Axis1	NOT (default) configurable, single-ended, 12~24V
		5	C+	Common	Command port of input signals for axis1 and axis2
		6	O1	O-Axis1	Alarm (default) configurable, common-cathode
		7	O2	O-Axis1	Brake (default) configurable, common-cathode
		8	I5	I-Axis2	Probe (default) configurable, single-ended, 12~24V
		9	I6	I-Axis2	HOME (default) configurable, single-ended, 12~24V
		10	I7	I-Axis2	POT (default) configurable, single-ended, 12~24V
		11	I8	I-Axis2	NOT (default) configurable, single-ended, 12~24V
		12	C-	Common	Command port of output signals for axis1 and axis2
		13	O3	O-Axis2	Alarm (default) configurable, common-cathode
		14	O4	O-Axis2	Brake (default) configurable, common-cathode

3.3.6 CN5-EtherNet/IP Communication Connector

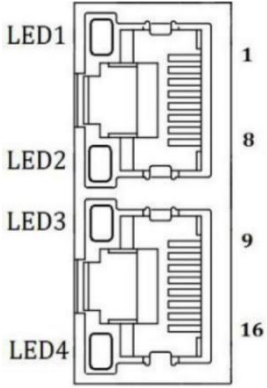
Name	Pic	PIN	Signal	Description
CN5		1, 9	E_TX+	EtherNet/IP TxD+
		2, 10	E_TX-	EtherNet/IP TxD-
		3, 11	E_RX+	EtherNet/IP RxD+
		4, 12	/	/
		5, 13	/	/
		6, 14	E_RX-	EtherNet/IP RxD-
		7, 15	/	/
		8, 16	/	/
		Cover	PE	Shield earthing
Note	(1) LED1 as 'Link/Activity IN' indicator, green (2) LED3 as 'Link/Activity OUT' indicator, green (3) LED2 as 'RUN' indicator, green (4) LED4 as 'ERR' indicator, red			

This LED informs EtherNet/IP communication status. RUN LED, ERROR LED positions at the front side of product and, Link/Activity LED individually positions at the top of right corner of EtherNet/IP ports.

Name	Color	Statue	Description
LED1	Green	OFF	Link not established in physical layer
		ON	Link established in physical layer
		Flickering	In operation after establishing link
LED3	Green	OFF	Link not established in physical layer
		ON	Link established in physical layer
		Flickering	In operation after establishing link

Table 3.3 Link/Activity LED status

3.3.7 Mini USB Tuning Port

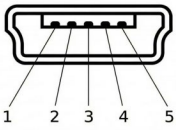
Name	Pic	PIN	Signal
CN6		1	GND
		2	Reserved
		3	Data+
		4	Data-
		5	V_Bus

3.3.8 STO Port

STO means Safe Torque Off, the STO function provides a means for preventing the drive from generating torque in the motor. It is suitable for incorporation into a safety system for a machine.

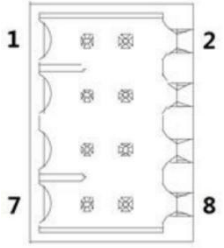
Port	Pin	Signal	Definition	Description
	1	24V	The power of STO	Using to short circuit the SF1 and SF2 signals, do not for other purpose
	2	0V		
	3	SF1+	The 1 st STO signal	One of SF1 or SF2 is activated, the STO would be activated
	4	SF1-		
	5	SF2+	The 2 nd STO signal	
	6	SF2-		
	7	EDM+	The output signal for monitor the state of STO function	The EDM signal would be ON while both SF1 and SF2 signals are OFF
	8	EDM-		

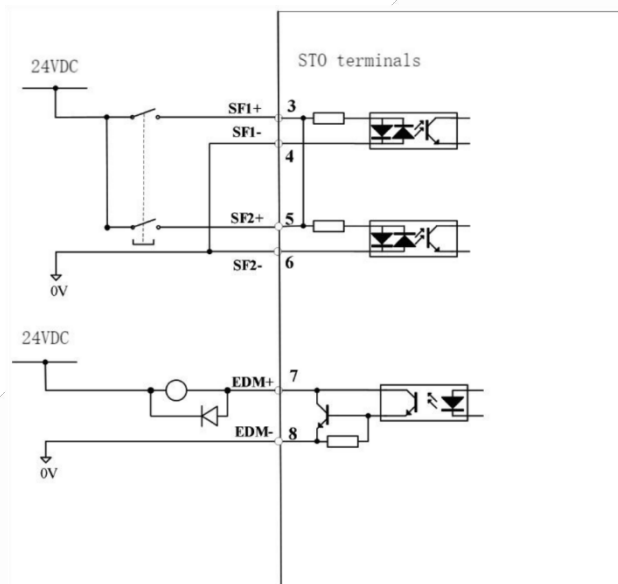

The Diagram of STO Circuit

Description about STO Alarm Code

SF1 State	SF2 State	EDM State	PWM State	Alarm
ON	ON	OFF	normal	/
ON	OFF	OFF	suspend	E1C2
OFF	ON	OFF	suspend	E1C1
OFF	OFF	ON	suspend	E1C0

3.3.9 Salve ID (Site Alias) Setting

The Salve ID (also called Site Alias) of 2CS3EIP series can be set by the following

3 methods:

- **Setting via Rotary Switches**

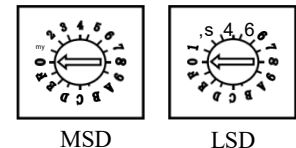

When Object (2151h) is set to value '0', user can set a value non-zero via the two rotary switches as the salve ID, activated after restarting the power supply. The specific definition is as below:

The salve ID of drives comes from the constituent hexadecimal value by rotary switch 1 (MSD) and rotary switch 2 (LSD). For example, when the MSD is set value 'A', and the LSD is set value '8', the ID is 168 (decimalism).

- **Setting via Reading Salve Controller**

When Object (2151h) is set to value '2' and MSD, LSD rotary switches are set to 0, the EtherNet/IP master will configure site alias to the address of EEPROM 0004h of slave controller automatically.

● **Setting via Object (2150h)**

When Object (2151h) is set to value '1', the value written in Object (2150h) is as the site alias, activated after saving parameter and restarting the power supply.

3.3.10 Three 7-Segment

There are three 7-Segments with two LED indicators on the front of 2CS3E-D507 (turn on when drive is enabled). The displayed content of after initialization can be set by Object (214b-00h):

- 2-Velocity
- 0-State machine / operation mode
- 1-Slave ID

When an error occurs, the 7-Segment displays only the alarm code, please refer to chapter 5.2

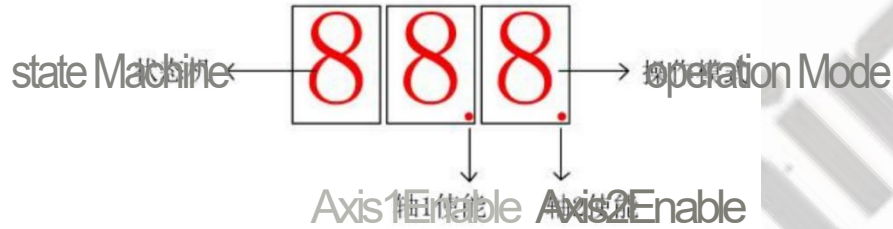

Figure 3.3: Three 7-Segments

3.4 I/O Interface and Corresponding Parameters Setting

3.4.1 Digital Input

- **Wiring**

There are two types of input signals: single-ended and differential. the connections are as below:

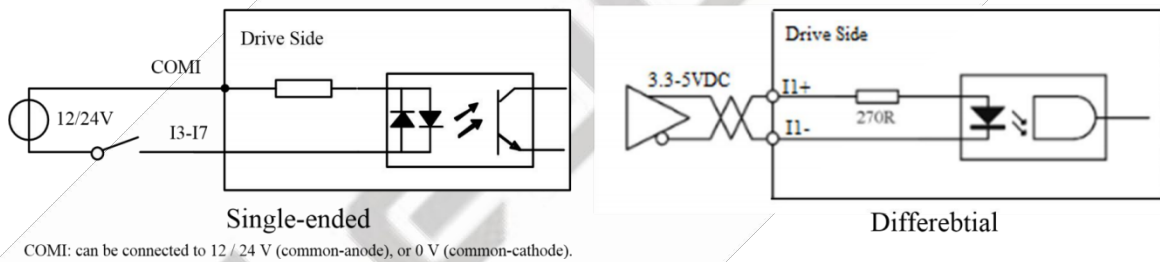

COM1: can be connected to 12 / 24 V (common-anode), or 0 V (common-cathode).

Figure 3.4: Input Interface Connection

Note:

- (1) Controller/PLC/Control card should provide input DC power 12-24V, current $\geq 100\text{mA}$.
- (2) If the polarity of input DC power is reversed, the EtherNet/IP stepper drive won't work; you need to turn the wiring.

3.4.2 Digital Output

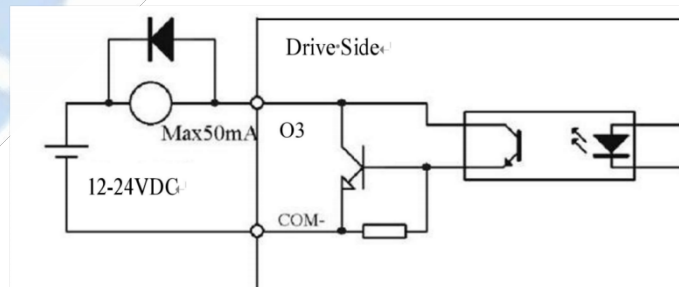

Figure 3.5: Output Interface Wiring

Note:

- (1) The power supply (12-24VDC) above is provided by user, and if the polarity of power supply is reversed, it will damage the drive.
- (2) Digital output is OC output with the maximum capacity of 100mA/30V (recommended 50mA/25V), the provided power supply should be under 30V (recommended 24V), otherwise it will cause damage to the drive.

3.4.3 Brake Output

The DO2 port of the 2CS3EIP series is configured as a brake output function. When this port is used for the brake function, an external intermediate relay is required. Additionally, a flyback diode must be connected in reverse parallel across the relay coil. The connection is below:

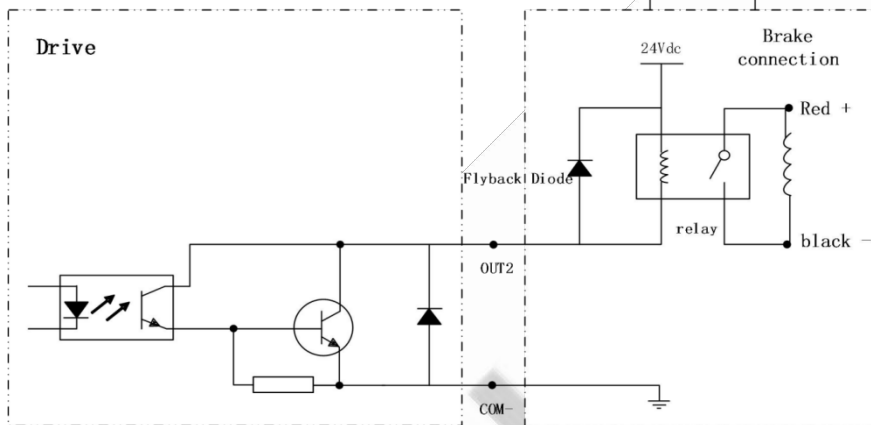

Figure 3.6: Brake output connection (The three object dictionaries related to the brake, 2403-01~03, are used for brake release delay and brake engagement delay respectively, and can be configured as needed;)

4 EtherNet/IP Object Dictionary

Each 2CS3EIP series product support two axes, except the parameters of 1000h~1FFFh are common parameters for axis1 and axis2, other parameters are working independently, the relation between these parameters show as follow:

Axis2 address (hex) = Axis1 address (hex) + 0x800

For example:

	Axis1	Axis2
Peak current	0x2000	0x2800
Target position	0x607A	0x687A

4.1 Communication Object

The 2CS3EIP Series drives follows the EtherNet/IP standard protocol, can communicate with the master stations which also supports the EtherNet/IP standard protocol.

Index	Sub-index	Name	Access	Type	Range	Default Value	Unit	Remark
1000	0	Device type	R	UINT	0-32767	0x40912	-	Refer to CIA 402 profile
1001	0	Error register	R	USINT	0-255	0	--	Refer to Chapter 5.1
1010	00	Number of sub-index	R	UINT	0-32767	4	-	-
	01	Save all parameters	R/W	UDINT	0-0xFFFFFFFF	0	-	Need to write 0x65766173 or 1702257011 (decimal) into sub-index. It will return 1 if save successfully
	02	Save communication parameters	R/W	UDINT	0-0xFFFFFFFF	0	-	
	03	Save motion parameters	R/W	UDINT	0-0xFFFFFFFF	0	-	
	04	Save parameters factory	R/W	UDINT	0-0xFFFFFFFF	0	-	
1011	00	Number of sub-index	R	UINT	0-32767	4	-	
1011	01	Restore all parameters to default setting	R/W	UDINT	0-0xFFFFFFFF	0	-	Need to write 0x64616f6c or 1684107116 (decimal) into sub-index. It will return 1 if save successfully
	02	Reset communication parameters of axis1 and axis2 to factory setting	R/W	UDINT	0-0xFFFFFFFF	0	-	
	03	Reset motion parameters of axis1 and axis2 to factory setting	R/W	UDINT	0-0xFFFFFFFF	0	-	
	04	Reset user parameters of axis1 and axis2 to factory setting	R/W	UDINT	0-0xFFFFFFFF	0	-	
	05	Reset motion parameters of axis1 to factory setting	R/W	UDINT	0-0xFFFFFFFF	0	-	
	06	Reset user parameters of axis1 to factory setting	R/W	UDINT	0-0xFFFFFFFF	0	-	
	07	Reset motion parameters of axis2 to factory setting	R/W	UDINT	0-0xFFFFFFFF	0	-	
	08	Reset user parameters of axis2 to factory setting	R/W	UDINT	0-0xFFFFFFFF	0	-	
1018	00	Number of sub-index	R	UINT	0-32767	4	-	-

	01	Vendor ID	R	UINT	0-32767	4321	-	Leadshine code
	02	Product code	R	UINT	0-32767	8X00	-	-
	03	Revision number	R	UINT	0-32767	1	-	-
	04	Series number	R	UINT	0-32767	1	-	-
1600	0	Number of sub-index	R/W	UINT	0-32767	3	-	Axis1 default number of 1 st mapping object
	01-08	1 st RXPDO-Map object	R/W	UDINT	0-0xFFFFFFFF	-	-	Axis1 default number of 1 st RXPDO-Map object
1601	0	Number of sub-index	R/W	UINT	0-32767	6	-	Axis1 default number of 2 nd mapping object
	01-08	2 nd RXPDO-Map object	R/W	UDINT	0-0xFFFFFFFF	-	-	Axis1 default number of 2 nd RXPDO-Map object
1602	0	Number of sub-index	R/W	UINT	0-32767	5	-	Axis1 default number of 3 rd mapping object
	01-08	2 nd RXPDO-Map object	R/W	UDINT	0-0xFFFFFFFF	-	-	Axis1 default number of 3 rd RXPDO-Map object
1603	0	Number of sub-index	R/W	UINT	0-32767	7	-	Axis1 default number of 4 th mapping object
	01-08	3 rd RXPDO-Map object	R/W	UDINT	0-0xFFFFFFFF	-	-	Axis1 default number of 4 th RXPDO-Map object
1610	0	Number of sub-index	R/W	UINT	0-32767	3	-	Axis2 default number of 1 st mapping object
	01-08	1 st RXPDO-Map object	R/W	UDINT	0-0xFFFFFFFF	-	-	Axis2 default number of 1 st RXPDO-Map object
1611	0	Number of sub-index	R/W	UINT	0-32767	6	-	Axis2 default number of 2 nd mapping object
	01-08	2 nd RXPDO-Map object	R/W	UDINT	0-0xFFFFFFFF	-	-	Axis2 default number of 2 nd RXPDO-Map object
1612	0	Number of sub-index	R/W	UINT	0-32767	5	-	Axis2 default number of 3 rd mapping object
	01-08	2 nd RXPDO-Map object	R/W	UDINT	0-0xFFFFFFFF	-	-	Axis2 default number of 3 rd RXPDO-Map object
1613	0	Number of sub-index	R/W	UINT	0-32767	7	-	Axis2 default number of 4 th mapping object
	01-08	3 rd RXPDO-Map object	R/W	UDINT	0-0xFFFFFFFF	-	-	Axis2 default number of 4 th RXPDO-Map object
1A00	0	Number of sub-index	R/W	UINT	0-32767	7	-	Axis1 default number of 1 st mapping object
	01-08	1 st TXPDO-Map object	R/W	UDINT	0-0xFFFFFFFF	-	-	Axis1 default number of 1 st TXPDO-Map object
1A01	0	Number of sub-index	R/W	UINT	0-32767	0	-	Axis1 default number of 2 nd mapping object
	01-08	2 nd TXPDO-Map object	R/W	UDINT	0-0xFFFFFFFF	-	-	Axis1 default number of 2 nd TXPDO-Map object
1A10	0	Number of sub-index	R/W	UINT	0-32767	7	-	Axis2 default number of 1 st mapping object
	01-08	1 st TXPDO-Map object	R/W	UDINT	0-0xFFFFFFFF	-	-	Axis2 default number of 1 st TXPDO-Map object
1A11	0	Number of sub-index	R/W	UINT	0-32767	0	-	Axis2 default number of 2 nd mapping object
	01-08	2 nd TXPDO-Map object	R/W	UDINT	0-0xFFFFFFFF	-	-	Axis2 default number of 2 nd TXPDO-Map object
1C00	0	Number of sub-index	R	UINT	0-32767	4	-	-
	01	Output type of email	R	UINT	0-32767	1	-	-
	02	Input type of email	R	UINT	0-32767	2	-	-

	03	Output type of process data	R	UINT	0-32767	3	-	-
	04	Input type of process data	R	UINT	0-32767	4	-	-
1C12	0-04	RXPDO assign	R/W	UINT	0-32767	1600	-	-
1C13	0-02	TXPDO assign	R/W	UINT	0-32767	1A00	-	-
1C32	0-0A	RXPDO administrative parameters	R	UINT	0-32767	-	-	-
1C33	0-0A	TXPDO administrative parameters	R	UINT	0-32767	-	-	-

The parameters can be configured by master station's PC software or Leadshine Motion Studio.

4.2 Manufacture Specific Object

Explanation for index and sub-index

Index	Sub- index	Name	Access for which axis
2000	00	Peak current	For axis1
2800	00		For axis2
2001	00	Microstep resolution	For axis1
2801	00		For axis2

Index	Sub-index	Name	Access	Type	Range	Default value	Unit	Remark
2000	00	Peak current	R/W/S	DINT	1-100	60	0.1A	Drive's max output current. 2CS3EIP-D503 is 25 by default; 2CS3EIP-D507 is 60 by default.
2800	00							
2001	00	Microstep resolution	R/W/S	DINT	200-51200	10000	Pulse	Required number of pulse to rotate 1 revolution of motor. But it is recommended to modify via 6092+01
2801	00							
2010	01	Internal filtering time	R/W/S	UINT	0-32767	100	0.1ms	Internal smoothing time for control command.
2810	01							
2012	00	Soft-starting time	R/W/S	UINT	10-3000	1	ms	Internal smoothing time for starting current.
2812	00							
2013	00	Auto-tuning at power on	R/W/S	UINT	0-2	1	--	1: Yes. 0: No
2813	00							
2019	01	In-position compensation pulse	R/W/S	UINT	0-1	1	--	0: With compensation, the value of 6064 = 607A in position; 1: Without compensation
2819	01							
2019	02	In-position mode at disabled state	R/W/S	UINT	0-1	0	--	0: Not allowed in-position signal output when disabled; 1: Allowed in-position signal output when disabled;
2819	02							
201A	01	Locking current percentage of power on	R/W/S	UINT	0-100	100	%	Usually keep the default value.
281A	01							
201A	02	Closed loop holding current percentage	R/W/S	UINT	0-100	50	%	Multiply by the value of object 0x2000, the drive output current will change between these according to the load.
281A	02							
201B	00	Locking duration time	R/W/S	UINT	0-1500	200	ms	Appropriately reduce this value if you want to shorten the time of locking shaft.
281B	00							
201C	00	Max time to close brake	R/W/S	UINT	100-10000	1000	ms	Usually keep the default value
281C	00							
201D	00	Zero speed point	R/W/S	UINT	0-500	10	0.1r/s	-
281D	00							
2024	00	Control Mode	R/W/S	UINT	0~10	2	--	0: Open Loop Control; 2: Closed Loop Control
2824	00							
2025	01	Speed point for open loop switching closed loop	R/W/S	UINT	0~200	18	0.1r/s	-
2825	01							
2025	02	Delay for open loop switching closed loop	R/W/S	UINT	0~32767	12	ms	-
2825	02							
2025	03	Speed point for closed loop switching open loop	R/W/S	UINT	0~200	5	0.1r/s	-
2825	03							
2025	04	Delay for closed loop switching open loop	R/W/S	UINT	0~32767	250	ms	-
2825	04							
2025	05	Feedback speed point for closed loop switching open loop	R/W/S	UINT	0~200	50	0.1r/s	-
2825	05							
2029	00	Encoder resolution	R/W/S	UINT	4000-20000	4000	Count	4 times the encoder resolution.

2829	00							But it is recommended to modify by 0x608F+01
2030	00	Allowed max position following error pulses	R/W/S	UINT	0~32767	4000	Count	4000 indicates the error of one turn
2830	00							
2032	00	Distance to send "In Position" output signal	R/W/S	UINT	0-1000	4	Pulse	-
2832	00							
2033	00	Delay of in-position error de-jitter	R/W/S	UINT	0-1000	3	ms	-
2833	00							
2047	00	Over voltage point	R	UINT	0-1000	75	V	-
2847	00							
2048	00	Bus-voltage	R	UINT	0-65535	-	V	-
2848	00							
2051	00	Motor running direction	R/W	DINT	0-1	0	--	0: CCW direction 1: CW direction But it is recommended to modify by 0x607E
2851	00							
2056	00	Alarm detection selection	R/W/S	DINT	0~65535	65535	--	Bit setting: = 1: Yes; =0: No Bit0: over-current (invalid) Bit1: over-voltage Bit2: Position following error Bit3: Encoder wiring error Bit4: over speed alarm
2856	00							
2057	00	Reset alarm	R/W/S	UINT	0~65535	0	--	Write value 1 to clear the alarm. But it is recommended to write value 128(Decimal) to 0x6040
2857	00							
2090	01	Current loop Kp	R/W	DINT	0~32767	1500	--	--
2890	01							
2090	02	Current loop Ki	R/W	DINT	0~32767	300	--	--
2890	02							
2090	03	Current loop Kc	R/W	DINT	0~32767	300	--	--
2890	03							
2091	01	Speed Loop Kp	R/W	UINT	0~10000	25	-	
2891	01							
2091	02	Speed Loop Ki	R/W	UINT	0~10000	3	-	
2891	02							
2092	01	Position Loop Kp	R/W	UINT	0~100	25	-	
2892	01							
2150	00	Slave ID	R/W/S	UINT	0-256	1	--	Valid when 0x2151= 1;
2151	00	Slave ID resource	R/W/S	UINT	0-10	0	--	0: DIP switches 1: Setting by 0x2150 2: ESC
2232	00	Synchronous compensation1	R/W	DINT	0—65535	2	--	--
2A32	00							
2233	00	Synchronous compensation2	R/W	DINT	0—65535	100	--	--
2A33	00							
225C	00	Special function register	R/W	DINT	0~32767	0	--	Bit1= 1: Set motor running direction by 0x607E Bit2= 1: Set virtual input by 0x5012-03
2A5C	00							
22A9	00	Limit Mode	R/W	DINT	0-10	0	--	0: Stop normally 1: Invalid 2: Alarm, error code 260
2AA9	00							
22B4	00	Quick stop selection	R/W	DINT	0~32767	0	--	0: Alarm, error code 570, 1: Refer to 0x605A
2AB4	00							
3100	01	Control software version	R	UINT			--	
	02	Firmware version	R	UINT			--	
	03	EtherNet/IP protocol version	R	UINT			--	
3FFE	01-0B	Alarm record	R	USINT	0~32767	--	--	0x3FFE+01 is the current error code (current alarm) or the most recent error code (currently no alarm); 0x3FFE+02-0E are followed by the historical error code.
47FE	01-0B							
4003	01	Delay of closing brake	R/W/S	UINT	0-1500	250	ms	
4803	01							
4003	02	Delay of loosening brake	R/W/S	UINT	0-1500	250	ms	
4803	02							

4003	03	Max speed to close brake	R/W/S	UINT	0-500	10	0.1r/s													
4803	03																			
5000	03	Internal enable state	R	UINT	0~32767	--	--	0: Disabled												
5800	03							1: Enabled												
5000	04	Reach the target state	R	UINT	0~32767	--	--	Bit0=0: Not reach												
5800	04							Bit0=1: Reach												
								Bit1=0: No stall												
								Bit1=1: Stalled												
5002	01	ESC ID	R/W	UINT	0~32767	0	--	Write 0, return the ID data in ESC to 0x5002-02;												
5802	01							Write 0x12, return the current ID setting by DIP switches												
5002	02	ESC data	R	UINT	0~32767	408	--	Return Node ID data												
5802	02																			
5004	0F	Sync0 Synchronization interface parameters	R/W	UINT	0~32767	--	--	Bit0 =1: RPDO mapping can't be written by SDO;												
5804	0F							Bit0 =0: RPDO mapping can be written by SDO;												
								Bit1=1: Detect the number of PDO mapping;												
								Bit1=1: Don't detect the number of PDO mapping;												
								Bit2=1: Send 0xF directly to enable;												
								Bit2=0: Send 0xF can't be enabled.												
5005	00	DC compensation base value	R/W	UINT	0~32767	500	--	--												
5805	00																			
5006	00	Synchronization error detection	R/W	UINT	0~32767	0	--	--												
5806	00																			
5011	00	Internal actual location	R	UDINT	0~32767	--	--	--												
5811	00																			
5012	01	Homing arrival position	R/W	DINT	0~32767	0	--	--												
5812	01																			
5012	02	Homing trigger position	R/W	DINT	0~32767	0	--	--												
5812	02																			
5012	03	Homing virtual input	R/W	UDINT	0~32767	0	--	When 0x225C=4, activate the virtual input function; 60FD different bits, corresponding to different virtual inputs;												
5812	03																			
								<table border="1"> <thead> <tr> <th>Inputs</th> <th>Bit of 60FD</th> </tr> </thead> <tbody> <tr> <td>Probe signal 1</td> <td>Bit 26=1</td> </tr> <tr> <td>Home switch</td> <td>Bit 2=1</td> </tr> <tr> <td>Positive limit</td> <td>Bit 1=1</td> </tr> <tr> <td>Negative limit</td> <td>Bit 0=1</td> </tr> <tr> <td>Z signal (index signal)</td> <td>Bit 31=1</td> </tr> </tbody> </table>	Inputs	Bit of 60FD	Probe signal 1	Bit 26=1	Home switch	Bit 2=1	Positive limit	Bit 1=1	Negative limit	Bit 0=1	Z signal (index signal)	Bit 31=1
Inputs	Bit of 60FD																			
Probe signal 1	Bit 26=1																			
Home switch	Bit 2=1																			
Positive limit	Bit 1=1																			
Negative limit	Bit 0=1																			
Z signal (index signal)	Bit 31=1																			
								For example: 0x225C=4 and start homing, set 0x5012-03=4, Home switch input; set 0x5012-03=2, Positive limit input; set 0x5012-03=2, Negative limit input												
5012	04	Homing setting	R/W	UINT	0~32767	5	--	Bit0=0: Homing protection is not turned on;												
5812	04							Bit0=1: Homing protection is turned on;												
								(Homing protection: when start homing, If the limit signal takes effect, bit0=0 means homing normally, bit0=1 means stop homing as limit protection)												
								Bit2=0: The value of current position after in position = 0x607C;												
								Bit2=1: The value of 0x607C is used as the motion offset, and finally 0x6064 = 0;												
								Bit3=0: 0x6064= 0x607C after in position;												
								Bit3=1: 0x6064 = 0x607C after in position;												
5400	01	Minimum synchronization period	R/W	UINT	250~2000	250	us	--												
5C00	01																			
5400	02	Maximum synchronization period	R/W	UINT	250~20000	10000	us	--												
5C00	02																			
5503	04	Special function register	R/W	UINT	0~65535	2	--	Bit0 = 0: Asynchronous mode, the host will track 0x607A-00 in real time;												
5D03	04							Bit0= 1: Asynchronous mode, the host does not track 0x607A-00in real time.												

4.3 I/O Configuration Object

The configuration of input ports includes three parts: function setting, filter time and polarity setting. Therefore, **the relevant object dictionary value (Decimal) = Input port function setting value + Filter time setting value + Input port polarity setting value.**

The configuration of output ports includes two parts: function setting and polarity setting. Therefore, **the relevant object dictionary value (Decimal) = Output port function setting value + Output port polarity setting value.**

It is recommended to use Leadshine free tuning software MotionStudio for parameter settings, which will be very simple. In Leadshine MotionStudio, digital input (DI) and digital output (DO) are displayed as SI and SO.

4.3.1 Input Ports Function Value

Index	Sub-index	Name	Access	Type	Range	Default value	Unit	Remark
2152	01	Input1 function	R/W/S	DINT	0-65535	0x17 (Decimal 23)	--	Default is touch probe1, take effect changes need restart power
2952	01							
2152	02	Input2 function	R/W/S	DINT	0-65535	0x18 (Decimal 24)	--	Default is HOME, take effect changes need restart power
2952	02							
2152	03	Input3 function	R/W/S	DINT	0-65535	0x16 (Decimal 22)	--	Default is POT, take effect changes need restart power
2952	03							
2152	04	Input4 function	R/W/S	DINT	0-65535	0x01 (Decimal 1)	--	Default is NOT, take effect changes need restart power
2952	04							

Note:

- (1) After configuring the input and output functions through the master station software or MotionStudio, it needs to save and restart the power to take effect.
- (2) If the function configuration of the two input ports is repeated, the input port with the smaller number is valid, and the other input port will be set to GPIO automatically. For example: SI3 and SI4 are configured as positive limit, after saving and restarting, SI3 function as positive limit, SI4 function as GPIO.

There are two object dictionaries that can be used to monitor input ports:
 0x2155 is used to monitor whether the input port is connected to a valid signal;
 0x60FD is used to monitor whether the input port is configured with a function

● **0x2155 Corresponding Input Port Table:**

Input port	Index +Sub index	Default Function Value	Default Function	Physical State Read State1 (3)
IN1	0x2152+01 (1)	0x17	Probe1	0x2155.00= 1 (2)
	0x2952+01			
IN2	0x2152+02	0x18	HOME	0x2155.01= 1
	0x2952+02			
IN3	0x2152+03	0x16	POT	0x2155.02= 1
	0x2952+03			
IN4	0x2152+04	0x01	NOT	0x2155.03= 1
	0x2952+04			

Note:

- (1) 0x2152+01 indicate that the index is 0x2152, and sub-index is 01.
- (2) 0x2155.01 indicates that the index is 0x2155, and bit is bit1.
- (3) Read State1: when IN1~IN7 inputs are valid, at this time, it has nothing to do with whether the function is configured, bit0~bit5 of 0x2155 will change to value 1. For example, when only IN5 input port is valid, bit 4 of 0x2155 will be value 1, then 0x2155=F (Decimal 16).

● **0x60FD Corresponding Function Table:**

Input Function	Setting Value	Logic state Read state2 (1)
Invalid	0x00	-
Probe1	0x17 (Decimal 23)	0x60FD.26= 1
		0x68FD.26= 1
Probe2	0x18 (Decimal 24)	0x60FD.27= 1
		0x68FD.27= 1
Home (ORG)	0x16 (Decimal 22)	0x60FD.02= 1
		0x68FD.02= 1
Positive limit (POT)	0x01 (Decimal 1)	0x60FD.01= 1
		0x68FD.01= 1
Negative limit (NOT)	0x02 (Decimal 2)	0x60FD.00= 1
		0x68FD.00= 1
Quick Stop (EMG)	0x14 (Decimal 20)	0x60FD.23= 1
		0x68FD.23= 1
GPIO (SI-MON)	0x19 (Decimal 25)	When IN1 is set to GPIO → 60FD.04= 1/ 68FD.04= 1
		When IN2 is set to GPIO → 60FD.05= 1/ 68FD.05= 1
		When IN3 is set to GPIO → 60FD.06= 1/ 68FD.06= 1
		When IN4 is set to GPIO → 60FD.07= 1/ 68FD.07= 1

Note:

- (1) Read State2: when inputs function is valid, at this time, it has nothing to do with which input port, bit0~bit26 of 0x60FD will change to value 1. For example: when IN5 input port is set to POT and input signal is valid, then bit0 of 0x60FD will be value 1.
- (2) When input function is set to GPIO, at this time, different input ports correspond to different bit of 0x60FD.

4.3.2 Input Ports Filter Time & Polarity Value

Filter Time	Setting Value (Decimal)		Polarity	Setting Value
1ms	0			Normally open (NO)
2ms	256		Normally closed (NC)	128
3ms	512			
4ms	768			
5ms	1024			
6ms	1280			
8ms	1536			
10ms	1792			
15ms	2048			
20ms	2304			
30ms	2560			
40ms	2816			
50ms	3072			
100ms	3328			
200ms	3584			
500ms	3840			

Therefore, Value of 0x2152 (Decimal) = Input port function value + Filter time value + Polarity value.

For Example:

1. IN1 needs to be set as quick stop function, filtering time is 20ms and polarity is NC(normal-closed):
 $0x2152+01 = 20+128+2304=2452(0x994)$
2. Need to set the polarity of IN3, IN4, and IN5 to NC:
 $0x2152+03 = 128+22 = 150(0x96)$
 $0x2152+04 = 128+1 = 129(0x81)$
 $0x2152+05 = 128+2 = 130(0x82)$

4.3.3 Output Ports Function & Polarity Value

Index	Sub-index	Name	Access	Type	Range	Default value	Unit	Remark	Status monitoring 1 of output
2156	01	Output1 function	R/W/S	DINT	0-65535	0x01	--	Default is alarm output, take effect changes need restart power	0x2155+00
2956	01								0x2955+00
2156	02	Output2 function	R/W/S	DINT	0-65535	0x04	--	Default is brake output, take effect changes need restart power	0x2155+01
2956	02								0x2955+02

More detail:

Output Port Function	Setting Value		Polarity	Setting Value
Reserved	0			Normally open (NO)
Alarm (ALM)	1		Normally closed (NC)	128
Servo-on (Ready)	2 (invalid)			
Brake (BRK)	3			

In-position (INP)	4 (invalid)		
Main control output	5		

Therefore, Value of 0x2156 (Decimal) = Output port function value + Polarity value.

For Example:

OUT1 needs to be set as alarm function and polarity is NC:

0x2156+01= 1+128= 129(0x81)

4.3.4 Main Control Output Function

Main control output is also called general output and User-defined output, and its usage is as follows:

Name	Index+ Sub-index	Polarity		Open main control output (60FE+01)	Enable main control output (60FE+02)
		NO (normal-open)	NC (normal-closed)		
OUT1	2156+01	0x05	0x85	bit16 (0x10000)	bit16 (0x10000)
	2956+01				
OUT2	2156+02	0x05	0x85	bit17 (0x20000)	bit17 (0x20000)
	2956+02				

For example, when OUT2 is set to main control output function and polarity is NC, the operation steps are as below:

- Set Object (2156+02h) to value 0x05 to main control output function;
- Set both 60FE+01 and 60FE+02 to value 0x20000, then it is available.

4.4 Motion Objects

Index	Name	Access	Type	Range	Default value	Unit	Remark
603F	Error code	R	UINT	0-65535	0	--	Refer to chapter 5.2
683F							
6040	Control word	R/W	UINT	0-65535	0	--	Refer to chapter 6.1
6840							
6041	Status word	R	UINT	0-65535	0	--	Refer to chapter 6.1
6841							
605A	Quick stop type selection	R/W	UINT	0-65535	6	--	0: After stopping immediately, switch on disable state; 1: After decelerating to stops at a speed value of 0x6084, switch on disable state; 2: After decelerating to stops at a speed value of 0x6085, switch on disable state; 3: After decelerating to stops at a speed value of 0x60C6, switch on disable state; 4: After stopping immediately, switch on quick stop state; 5: After decelerating to stops at a speed value of 0x6084, switch on quick stop state; 6: After decelerating to stops at a speed value of 0x6085, switch on quick stop state; 7: After decelerating to stops at a speed value of 0x60C6, switch on quick stop state;
685A							
605D	Asynchronous mode halt selection	R/W	INT	0~65535	1	--	1: After decelerating to stops at a speed value of 0x6084, keep operation enable state; 2: After decelerating to stops at a speed value of 0x6085, keep operation enable state; 3: After decelerating to stops at a speed value of 0x60C6, keep operation enable state; 4: After stopping immediately, keep operation enable state.
685D							
6060	Operation mode	R/W	USINT	0-255	8	--	1: PP mode, 3: PV mode, 6: Home mode,
6860							
6061	Operation mode display	R	USINT	0-255	8	--	-
6861							
6062	Position command	R	DINT	-2147483648 ~2147483647	0	Pulse	-
6862							
6064	Position actual	R	DINT	-2147483648	0	Pulse	-

6864	value			~2147483647			
6067	Distance to send "In Position" output signal	R/W/S	UINT	0-1000	4	Pulse	It is recommended to use this object in preference, Can also set by 0x2032,
6867							
606B	Velocity command	R	DINT	-2147483648 ~2147483647	0	P/s	-
686B							
606C	Velocity actual value	R	DINT	-2147483648 ~2147483647	0	P/S	-
686C							
607A	Target position	R/W	DINT	-2147483648 ~2147483647	0	P	Target position under PP mode
687A							
607C	Home offset	R/W	DINT	-2147483648 ~2147483647	0	P	The value of difference between zero position and mechanical zero point under Homing mode . If the value is set to10000, it means that at homing mode 19, the motor reaches the Home switch and stops immediately, then reverses at low speed until it leaves the Home switch, at last stops at a distance of 10000P.
687C							
607D+01	Software negative limit	R/W	DINT	-2147483648 ~2147483647	0	P	New target positions are checked against these limits. The limits are relative to the machine home position, which is the result of homing. As default the software position limits are switched off. Changed values must be saved and the drive must be restarted to take enable the new the software limits.
687D+01							
607D+02	Software positive limit	R/W	DINT	-2147483648 ~2147483647	0	P	
687D+02							
607E	Motor direction	R/W	USINT	0~255	0	--	Need to set 0x225C first
687E							
60FF	Target velocity	R/W	DINT	-2147483648 ~2147483647	0	P/S	Profile velocity under PV mode
68FF							
6080	Max velocity limit	R/W/S	UDINT	-2147483648 ~2147483647	3000	rpm	-
6880							
6081	Max profile velocity	R/W/S	DINT	-2147483648 ~2147483647	50000	--	Max. Allowable velocity under PP mode
6881							
6082	Start velocity	R/W/S	DINT	-2147483648 ~2147483647	0	--	Start velocity under PP mode
6882							
6083	Profile acceleration	R/W/S	DINT	-2147483648 ~2147483647	4000	P/S^2	Acceleration under PP and PV mode
6883							
6084	Profile deceleration	R/W/S	DINT	-2147483648 ~2147483647	4000	P/S^2	Deceleration under PP and PV mode
6884							
6085	Quick stop deceleration	R/W/S	DINT	-2147483648 ~2147483647	4000000 00	P/S^2	Deceleration of quick stop under PP, PV and Home mode
6885							
608F+01	Encoder resolution	R/W/S	UINT	4000-20000	4000	Count	It is recommended to use this object in preference, can also set by 0x2029,
688F+01							
6092+01	Microstep resolution	R/W/S	DINT	200-51200	10000	Pulse	It is recommended to use this object in preference,can also be modified via 0x2001,
6892+01							
6098	Homing method	R/W/S	USINT	1-100	19	-	Methods of searching zero position under homing mode, refer to Appendix A
6898							
6099+01	Fast homing velocity	R/W/S	DINT	-2147483648 ~2147483647	50000	P/S	Speed during search for limit switch signal
6899+01							
6099+02	Slow homing velocity	R/W/S	DINT	-2147483648 ~2147483647	25000	P/S	Speed during search for Home switch
6899+02							

607C	Home offset	R/W/S	DINT	-2147483648	0	P	The value of difference between zero position and mechanical zero point under Homing mode
687C				~2147483647			
609A	Homing acceleration	R/W/S	USINT	-2147483648	25000	P/S^2	Acc / Dec velocity under Home mode
689A				~2147483647			
60B0	Position offset	R/W	DINT	-2147483648	0	P	Position offset under PP mode
68B0				~2147483647			
60B8	Touch probe control word	R/W	UINT	0-65535	0	-	Set touch probe function, refer to chapter 6.3
68B8							
60B9	Touch probe statue word	R	UINT	0-65535	0	-	Status of touch probe 1/2, refer to chapter 6.3
68B9							
60BA	Touch probe 1 positive value	R	DINT	-2147483648	0	P	Data value sensed by touch probe 1 at rising edge
68BA				~2147483647			
60BB	Touch probe 1 negative value	R	DINT	-2147483648	0	P	Data value sensed by touch probe 1 at falling edge
68BB				~2147483647			
60BC	Touch probe 2 positive value	R	DINT	-2147483648	0	P	Data value sensed by touch probe 2 at rising edge
68BC				~2147483647			
60BD	Touch probe 2 negative value	R	DINT	-2147483648	0	P	Data value sensed by touch probe 2 at falling edge
68BD				~2147483647			
60C2+01	Interpolation time period value	R/W	USINT	0-255	2	--	Only for internal tuning.
68C2+01							
60C2+02	Interpolation time unit	R/W	SINT	-128-127	0	--	
68C2+02							
60D5	Touch probe 1 rising edge counter	R	UINT	0-65535	0	--	Frequency for capture of touch probe 1 rising edge
68D5							
60D6	Touch probe 1 falling edge counter	R	UINT	0-65535	0	--	Frequency for capture of touch probe 1 falling edge
68D6							
60D7	Touch probe2 rising edge counter	R	UINT	0-65535	0	--	Frequency for capture of touch probe 2 rising edge
68D7							
60D8	Touch probe 2 falling edge counter	R	UINT	0-65535	0	--	Frequency for capture of touch probe 2 falling edge
68D8							
60FD	Digital input statue	R	UDINT	0- 4294967296	0	--	Statue of digital input signals, refer to chapter 4.3. 1
68FD							
60FE+01	Open physical output	R/W/S	UDINT	0- 4294967296	0	--	Able to control user output through this object, refer to chapter 4.3.4
68FE+01							
60FE+02	Enable physical output	R/W/S	UDINT	0- 4294967296	0	--	
68FE+02							

4.5 XML File or ESI File

EtherNet/IP Slave Information file (XML File or ESI file) is needed to connect controller with EtherNet/IP Master.

This file is provided by Leadshine, described slave device information as XML format based on EtherNet/IP specifications. Please follow the EtherNet/IP master software manual for importing method.

Some master stations require files in a specific format and do not recognize XML format, please contact the master technical engineer of master station.

5 Two 7-Segment and Error Code

5.1 Two 7-Segment

2CS3EIP has two 7-Segment with a LED indicate respectively (the right LED will be on when the drive is enabled), and the contents displayed are different in the initialization status and operational status.

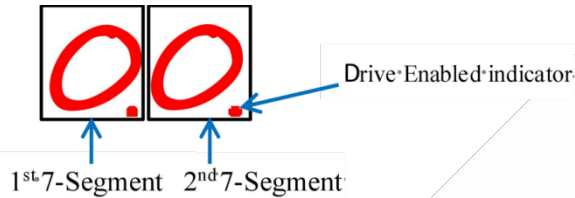

Figure 5.1: Two 7-Segment display

5.1.1 Initialization Status

After the drive is powered on, the two 7-Segment displays are fully lit by 0.5s, followed by a number (max FF) in hex showing the actual node address of the drive. Then the displayed number will be flashing for 5S.

If the node address of the drive is changed during initialization status or running status, the segment displays will be flashing and back to the former status after 5s.

5.1.2 Operational Status

The drive goes into operational status after initialization, and the contents displayed on the 7-Segment are configurable, can be set to three types and set by Object (214b-00h).

Index	Value	Name	Description
214b-00h	2	Velocity	Unit: rps
	0	Status Machine & Operation Mode	(1) 1 st 7-Segment displays the information of status machine in hex . 1: Initialization . 2: Pre-operation . 4: Safe Operation . 8: Operation (2) 2 nd 7-Segment displays the information of operation mode in hex . 1: PP (Profile Position) . 3: PV (Profile Velocity) . 6: HM (Homing)
	1	Salve ID	The Salve ID will be displayed always

Note: If change the node address through rotary switches MSD and LSD during the status of operation, the 7-Segment tube will blinking display the new node address in the time of 5S, then restore the information it had displayed.

5.2 Error Code

(1) Object **0x3FFE+01** indicates the current failure alarm, and other sub-index indications are historical alarms.

(2) Object **0x1001** and **0x603F** indicate the current failure alarm, The error code read by 0x603F is IEC 61800 specification; the error code read by 0x1001 is CIA specification.

(3) Error code read by some master station is displayed in decimal. At this time, please convert it to hexadecimal and then refer to the error code table as below. For example, the master station reports error code of 8721, the corresponding hexadecimal number is 0x2211, so the alarm information in the reference table is over-current alarm.

If error occurred, the LED will show the error code of related axis, show as bellow: (for example, axis1 shows E180 and axis 2 shows E152)

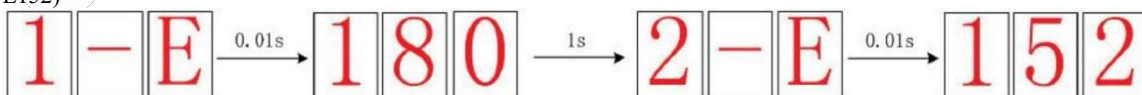

Error code table

0x3FFE Value	0x603F Value	Description	Trouble Shooting
0x0e0	0x2211	Over-current	1. Check whether the wiring is short-circuited, or the motor is short-circuited. 2. Switch power supply alarm caused, replace other power supply for a try.
0x0c0	0x3211	Over-voltage	1. Check the voltage of power supply; 2. If over-voltage occurs in motion, the acceleration and deceleration time can be increased
0x0a0	0x3150	EEPROM error in phase A	1. Reset parameters to the factory and restart power supply 2. If it still exists, the hardware failure
0x0a1	0x3151	EEPROM error in phase B	
0x1a0	0x8402	Over-speed	1. Reduce command speed value; 2. Write 0x10 to the object 0x2056 to clear the alarm.
0x240	0x5530	Save error	1. Reset parameters to the factory and restart power supply 2. If it still exists, the hardware failure
0x260	0x7329	Limit switched alarm	Refer to 0x22A9+00
0x570	0x5441	Quick stop alarm	Refer to 0x22B4+00
0x5f0	0x7122	Auto-tuning error	1. Restart the drive; 2. If it still exists, disable auto-tuning by 0x2013
-	0x7321	Encoder wiring error	1. The drive is not connected to a motor; 2. If alarm is occurred when connect a motor, please check the encoder wiring or a cable break.
0x816	0x8216	Invalid mailbox configuration in pre-operation state	Check the network cable
0x81b	0x821B	Watchdog timeout	Check the network cable
-	0x8611	Position following error	1. Set the value of Object 2024h to "0" to make motor run in open loop mode, If alarm disappears, it means encoder wiring error; 2. Motor torque is not enough or motor speed is too high;
0x836	0x8736	Invalid DC synchronization period	Decrease the value of the synchronization period or increase the value of 0x5400+02
0x870	0x5201	Unsupported operation mode	Check the value of 0x6061 and correct it to the supported operation mode;
0x801	0x8201	ESM state machine transition failed	Alarms related to the master station, without accurate solution.
0x802	0x5510	Memory overflow	
0x807	0x8207	The mapping object does not exist	
0x808	0x8208	PDO mapping object length error	
0x809	0x8209	PDO mapping object has no mapping attribute	
0x811	0xA001	Invalid ESM conversion request	
0x812	0xA002	Unknown ESM conversion request	
0x813	0x8213	Boot state request protection	
0x815	0x8215	Email configuration with invalid boot status	
0x818	0x8211	No valid input data	
0x819	0x8212	No valid output data	
0x81c	0x821C	Invalid sync manager type	
0x81d	0x821D	Invalid output configuration	
0x81e	0x821E	Invalid input configuration	
0x821	0xA003	Waiting for the initial state of ESM	
0x822	0xA004	Waiting for ESM pre-operation state	
0x823	0xA005	Waiting for ESM safe operation status	
0x824	0x8224	Invalid process data input mapping	
0x825	0x8225	Invalid process data output mapping	
0x827	0x8727	Free running mode is not supported	
0x828	0x8728	Does not support synchronous mode	

0x82b	0x8210	Invalid input and output
0x82c	0x872C	Fatal sync error
0x82d	0x872D	No synchronization errors
0x82e	0x872E	Synchronization period is too small
0x830	0x8730	Invalid DC synchronization configuration
0x832	0x8732	DC phase locked loop failure
0x833	0x8733	DC sync IO error
0x834	0x8734	DC synchronization timeout
0x835	0x8735	Invalid DC cycle
0x850	0x5550	EEPROM inaccessible
0x851	0x5551	EEPROM error
0x852	0x5552	The hardware is not ready

5.3 Alarm Clearing

After the 2CS3EIP drive alarms, the power should be cut off first to check the fault, especially the over-current and over-voltage faults. Some alarms (except over-voltage and over-current) can be cleared when the drive is holding on, the step is as follows:

- Write 0x80 (decimal 128) to the object 0x6040 to clear the current alarm (except over-voltage and over-current). [This method is recommended as a priority](#);
- Or write 1 to the object 0x2093 to clear the historical alarm records. At this time, all sub-indexes of 0x3FFE are cleared;

6 Common Functions

6.1 Saving Parameters and Resetting Drive

To save all storable parameters into EEPROM through Object 0x1010, need to write “0x65766173” into sub-index 01h. To reset the drive to default parameters through Object 0x1011, need to write “0x64616F6C” into sub-index 01h. **After writing the save command, do not turn off the power immediately, wait around 10s to ensure that all parameters have been saved successfully.** The below table is the description of Object (1010h) and Object (1011h).

Table 6.1: Object (1010h) and Object (1011h)

Action	Index Sub-index	Write Command (hex)	Return Value	Description
Save Objects (2000h-5000h)	1010+04	0x65766173	Return 1	Save Manufacture Specific Objects
Save Objects (6000h)	1010+03	0x65766173	Return 1	Save Motion Objects
Save Objects (1000h)	1010+02	0x65766173	Return 1	Save Communication Objects
Save all Objects	1010+01	0x65766173	Return 1	Save all Objects
Restore Objects (2000h-5000h)	1011+04	0x64616F6C	Return 1	Reset Manufacture Specific Objects
Restore Objects (6000h)	1011+03	0x64616F6C	Return 1	Save Motion Objects
Restore Objects (1000h)	1011+02	0x64616F6C	Return 1	Reset Communication Objects
Restore all Objects	1011+01	0x64616F6C	Return 1	Reset all Objects

6.2 Control Word and Operation Modes

2CS3EIP supports asynchronous mode. In asynchronous motion mode, master station is only responsible for sending motion parameters and control commands. 2CS3EIP drives will process trajectory planning according to the motion parameters after receives control command from master station and the movements between each axis are asynchronous. 2CS3EIP asynchronous mode includes Profile Position mode (PP), Profile Velocity mode (PV) and Homing mode (HM).

In both control modes, EtherNet/IP data transmission between master and slave station is achieved through object dictionary. The transmission types contain PDO and SDO and only one can be chosen in general cases. According to control needs, it is classified in three levels by data transmission real time capability and importance:

Must > Recommend > Can.

- “Must” indicates under this mode, the object dictionary has to be PDO mode;
- “Recommend” indicates under the set mode, the object dictionary is suggested to be configured as PDO mode to achieve real-time capability but SDO transmission can be allowed if the controlling is not quite demanding;
- ”Can” indicates under this mode, object dictionary data transmission is generally through SDO mode and PDO communication mode won't be necessary.

The object dictionary of each control mode is shown as below:

Table 6.2: Objects Dictionary related to each operation mode

Operation Modes	Index Sub-index ⁺	Name	Data Type	Access	Unit	PDO Configuration	SDO Configuration
PP Mode (1)	607A+00	Target Position	I32	RW	P	Recommend	Can
	6081+00	Max Profile Velocity	U32	RW	P	Can	Can
PV Mode (3)	60FF+00	Target Velocity	I32	RW	P	Recommend	Can
PP Mode (1) And PV Mode (3) General	6040+00	Control Word	U16	RW	—	Recommend	Can
	6083+00	Profile Acceleration	I32	RW	P/S ²	Can	Can
	6084+00	Profile Deceleration	U32	RW	P/S ²	Can	Can
Homing Mode (6)	6040+00	Control Word	U16	RW	—	Recommend	Can
	6098+00	Homing Method	I8	RW	—	Can	Can
	6099+01	Fast Homing Velocity	U32	RW	P/S	Can	Can
	6099+02	Slow Homing Velocity	U32	RW	P/S	Can	Can
	609A+00	Homing Acceleration	U32	RW	P/S ²	Can	Can
	607C+00	Homing Offset	U32	RW	P	Can	Can

PP, PV and HOME Mode General	6041+00	Status Word	U16	RO	—	Recommend	Can
	6064+00	Actual Position	I32	RO	P	Recommend	Can
	606C+00	Actual Velocity	I32	RO	P/S	Can	Can
All operation modes General	60B8+00	Touch Probe Control Word	U16	RW	—	Recommend	Can
	60B9+00	Touch Probe Status Word	U16	RO	—	Recommend	Can
	60BA+00	Touch Probe 1 Positive Value	I32	RO	P	Can	Can
	60FD+00	Digital Input Status	U32	RO	—	Recommend	Can
	603F+00	Latest Error Code	U16	RO	P	Recommend	Can
Other Related	6060+00	Operation Mode	I8	RW	—	Can	Can
	60B0+00	Position Offset	I32	RW	—	Can	Can
	6082+00	Start Velocity	U32	RW	P/S	Can	Can
	6085+00	Quick Stop Deceleration	U32	RW	P/S ²	Can	Can
	6061+00	Displayed Operation Mode	I8	RO	—	Can	Can

No matter using which operation mode, it cannot be separated from the reading and writing of Control Word (6040h) and Status Word (6041h). Master and slave stations use these two object dictionaries as a medium to send instructions and monitor status. Following contents will highlight the definitions of each bit of the two object dictionaries.

The bit definition of Control Word (6040 h) is as shown in Table 6.3. The table A is about bit4, bit5, bit6 and bit8, whose definition depend on the operation mode, and mainly cover the execution, stop, etc. of each operation mode. The table B is about bit0-3 and bit7, which manages the state transition of the 402 state machines. The definition of Status Word (6041h) is as shown in Table 6.4. The bit0 -7 mainly show the state machine transition state, while the bit8-15 mainly shows the status of execution or stop in each operation mode. The typical state transition of enable is as follows:

Initiation (00h) -> power-on (06h) -> start (07h) -> enable (0fh) -> execute or pause (depending on operation mode to send related control instructions of bit4-6 and bit8). The state transition that triggers the running control in each control mode is shown in Table 6.5.

Table 6.3A: Control Word (6040h) Bit Definition

Mode Bit	15-9	8	6	5	4
General	-	Pause	Depending on the operation mode		
PP mode (1)	-	Deceleration stop	Absolute / Relative	Immediate trigger	New position point
PV mode (3)	-	Deceleration stop	Invalid	Invalid	Invalid
HM mode (6)	-	Deceleration stop	Invalid	Invalid	Starting motion

Table 6.3B: Control Word (6040h) Bit Definition

Mode Bit	7	3	2	1	0	Type value	Action
General	Wrong reset	Permitted operation	Quick stop	Voltage output	Start		
PP mode (1)	0	0	1	1	1	07h	Start
PV mode (3)	0	0(x)	0	1	0(x)	02h	Quick
HM mode (6)	0	1	1	1	1	0fh	Enable
-	1	0(x)	0(x)	0(x)	0(x)	80h	Clear error
-	0	0	0	0	0	0	Initiation

Additional information on other bits:

- . Bit 2 is quick stop, trigger logic is 0 effective, notice to separate from other trigger logic.
- . Bit 7 is error reset, trigger logic is rising edge effective.
- . Bit 5 is immediate trigger, trigger logic is rising edge effective.

Table 6.4 Status Word(6041h) Bit Definition

Mode Low 8 bits	7	6	5	4	3	2	1	0
Shared	Reserved	Not started	Quick stop	Power on	Error	Permitted operation	Start	Ready to start
Mode / high 8 bits	15	14	13	12	10	8	11	9
Shared	Depending on the operation mode						Limit validity	Distance
PP mode (1)	Trigger response	Parameter has 0	Invalid	New position point response	Position arrival	Emergency stop		
PV mode (3)	Invalid	Parameter has 0	Invalid	Speed is 0	Velocity arrival	Quick stop		
HM mode (6)	Trigger response	Parameter has 0	Homing error	Homing find	Position arrival	Emergency stop		

Additional information on other bits:

- . When the drive is put into power, the bit 4 will be set.
- . Bit 5 quickly stops activation, which is valid under logic 0, contrary to the logic of other bits.
- . Bit 9 remote, showing the state of the communication state, 0 below ProOP, at this time the control word (6040 h) command will not be executed.
- . Bit 11 limit is set only, when the hardware limit is valid.
- . Bit 8 abnormal stop is generally valid in hardware limit, deceleration stop and fast stop trigger state.
- . Bit 12 follows the master station.

Table 6.5: State transition of each mode control operation

Mode Action	PreOP	Initialization	Get power	Start	Enable	Start operation	Change position	Stop	Alarm	
PP mode (1)	6040	Create a communication OP state, setting motion parameters	00h	06h	07h	0fh	2fh	3fh	13fh	Over-voltage
	6041		650h	631h	633h	8637h	8637h	1237h	737h	638h
PV mode (3)	6040	Create a communication OP state, setting motion parameters	00h	06h	07h	0fh	Immediate operation after enabling	Change the speed	10fh	Over-voltage
	6041		650h	631h	633h	637h	637h	237h->637h	737h	638h
HM mode (6)	6040	Create a communication OP state, setting motion parameters	00h	06h	07h	0fh	1fh	Error / Completion	11fh	Over-voltage
	6041		650h	631h	633h	8737h	237h	2637h / 1637h	737h	638h

Additional information on other bits:

- . When the PP mode changes the position, it needs to give the bit5 rising edge of the control word to start the new position motion.

6.3 Touch Probe

Touch probe function is to capture and record the actual position of the motor by using the input signal with the touch probe function. The 3CS3EIP driver has two input I/O signals to support the probe function and can be enabled at the same time. The probe function related object dictionaries are shown in Table 6.6.

Table 6.6: Related Object Dictionaries of Touch Probe

Index	Bit Definition					
	7-6	5	4	3-2	1	0
60B8h	-	Touch Probe 1 falling edge trigger	Touch Probe 1 rising edge trigger	-	Touch Probe 1 mode	Touch Probe 1 enable
	15-14	13	12	11-10	9	8
	-	Touch Probe 2 falling edge trigger	Touch Probe 2 rising edge trigger	-	Touch Probe 2 mode	Touch Probe 2 enable
60B9h	7	6	5-3	2	1	0
	Actual level of touch probe 2	Actual level of Touch Probe 1		Touch Probe 1 falling edge trigger complete	Touch Probe 1 rising edge trigger complete	Touch Probe 1 action
	15-11			10	9	8
	-			Touch Probe 2 falling edge trigger complete	Touch Probe 2 rising edge trigger complete	Touch Probe 2 action
60BAh	Touch Probe 1 rising edge capture data value register					
60BBh	Touch Probe 1 falling edge capture data value register					
60BCh	Touch Probe 2 rising edge capture data value register					
60BDh	Touch Probe 2 falling edge capture data value register					
60FDh	The state of bit26 is bit 1 and bit 2 AND logic of Object (60B9h); The state of bit27 is bit 9 and bit 10 AND logic of Object (60B9h)					
2152h	It can be configured as probe 1 or probe 2 by writing its sub-indexes 01h and 02h to 17 or 18.					

Additional information on other bits:

- The bit0 and bit8 of Object (60B8h): start/stop control bit of Touch Probe 1 and Touch Probe 2 respectively, and the rising edge is effective.
- The bit1 and bit9 of Object (60Bh): Touch Probe modes are divided into single mode and continuous mode.
 - Single mode: After a Touch Probe is activated; it is captured only under the first trigger signal. In order to capture the new position value again, the bit0 /bit8 of the Object (60B8h) must be given a rising edge signal to restart the probe action.
 - Continuous mode: After a Touch Probe is activated; the capture action is carried out under each trigger signal.

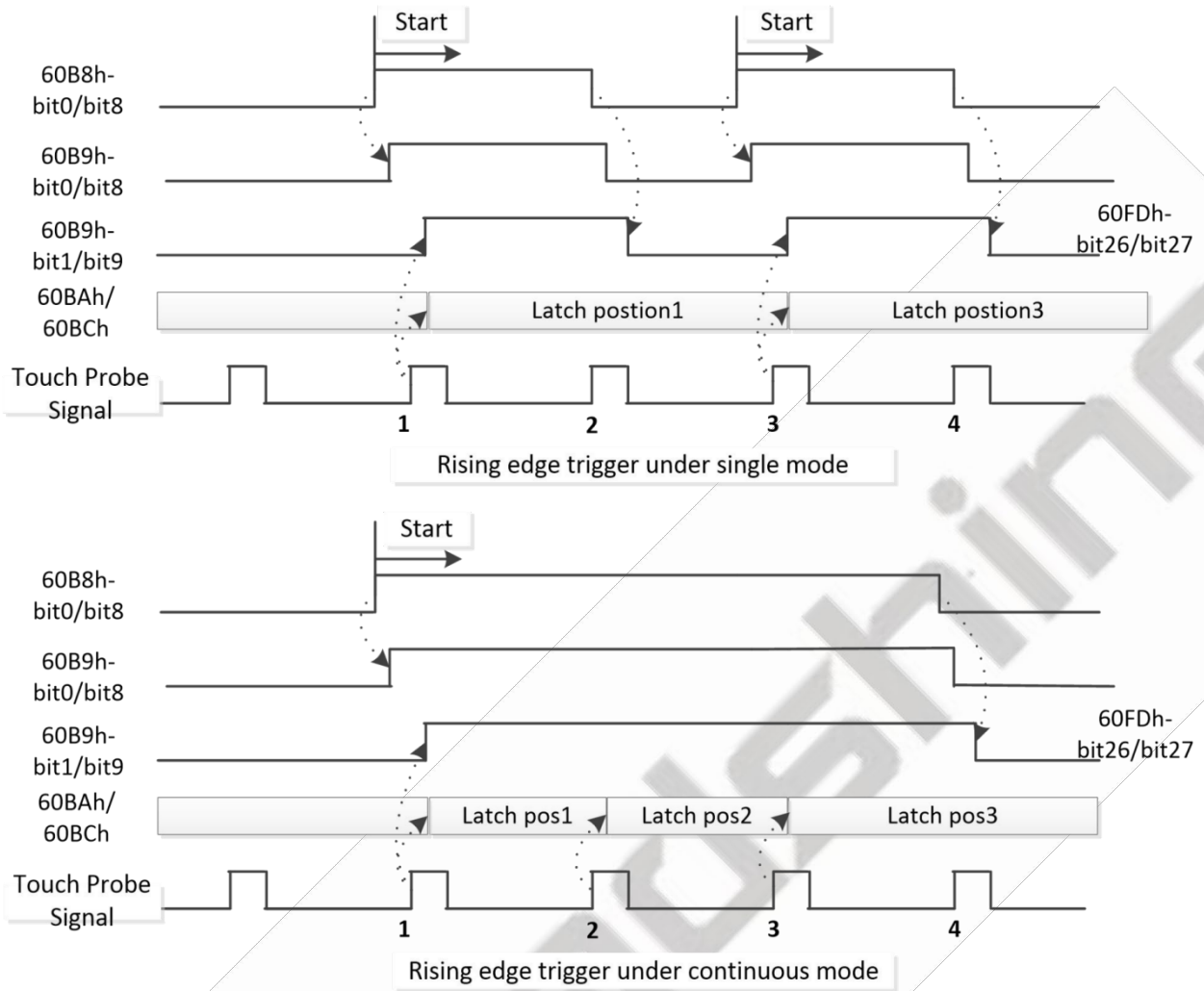

Figure 6.1: Touch Probe Mode

Appendix A: Homing Methods

The 2CS3EIP series drives support homing method -1, -2, 1 - 14, 17 - 34, and method 35 & 37. Specific definition and the process of homing methods described below.

Z Signal: Index signal, Bit31 of Object 60FDh set to 1;

Stalling Signal: After the motor is stalled, if the position error is greater than the value of Object 22EFh (default = 2000), the stalling signal is triggered (bit1 of Object 5000+04h set to 1);

Zero Position: a fixed position on the machine can correspond to a definite digital input signal, or to a Z signal

Zero Point of Machine: mechanical absolute zero position

Home offset: difference between zero position and zero point of machine, the value of Object 607Ch (default = 0), Zero position = zero point + home offset

Home Switch: homing switch input signal

Negative Limit: negative limit switch input signal

Positive Limit: positive limit switch input signal

- **Method -1 requires Z signal and Stalling Signal.**

During the motor running in negative direction, when reaching the stalling signal, it will slow down and stop, then run in reverse, at last stops immediately when reaching the first Z signal. (Z signal as the zero position)

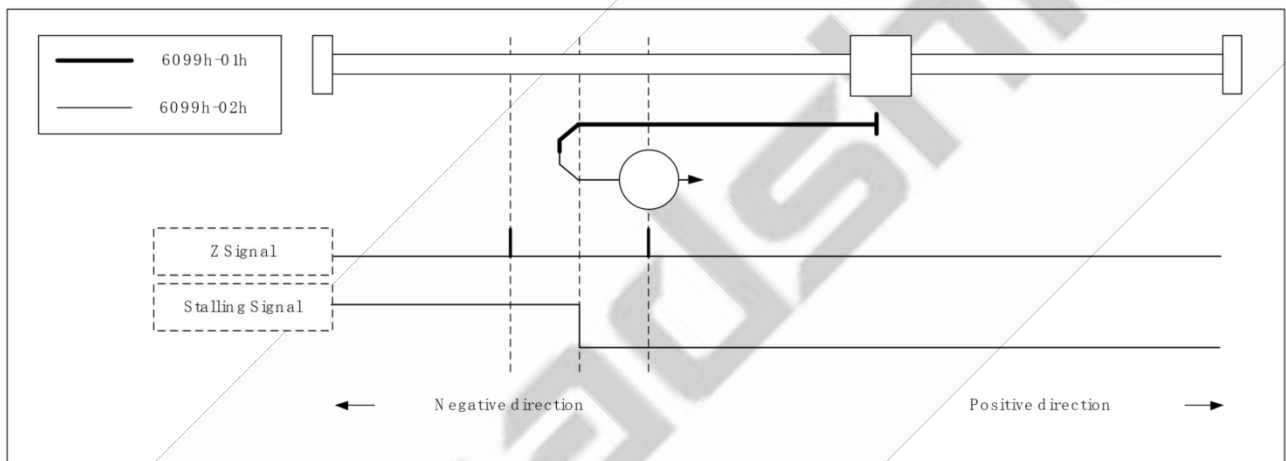

Method -1

- **Method -2 requires Z signal and Stalling Signal.**

During the motor running in positive direction, when reaching the stalling signal, it will slow down and stop, then run in reverse, at last stops immediately when reaching the first Z signal. (Z signal as the zero position)

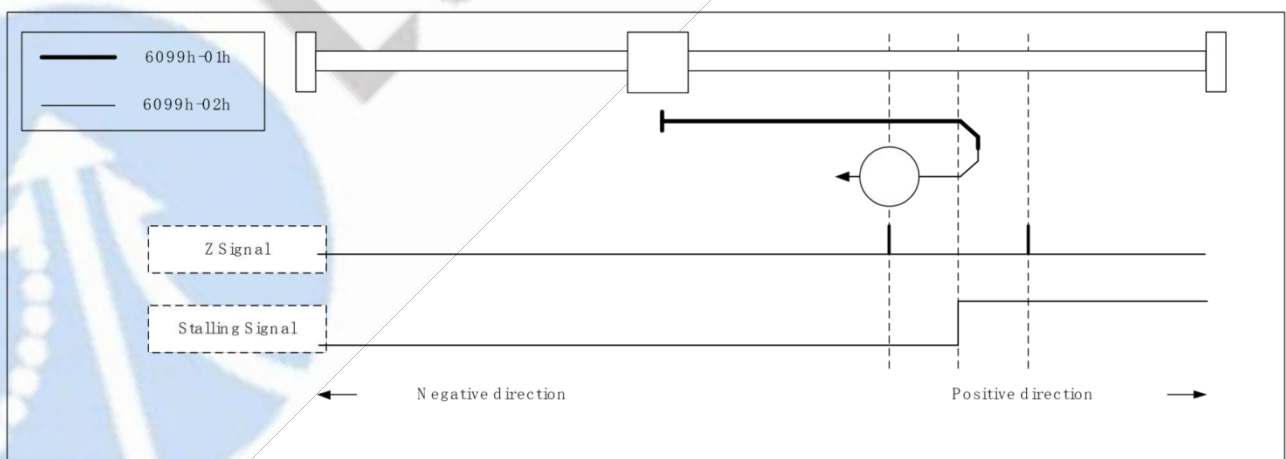

Method -2

- **Method -3 requires Stalling Signal.**

During the motor running in positive direction, when reaching the stalling signal, it will slow down and stop, then run in reverse, at last stops. (stop position as the zero position)

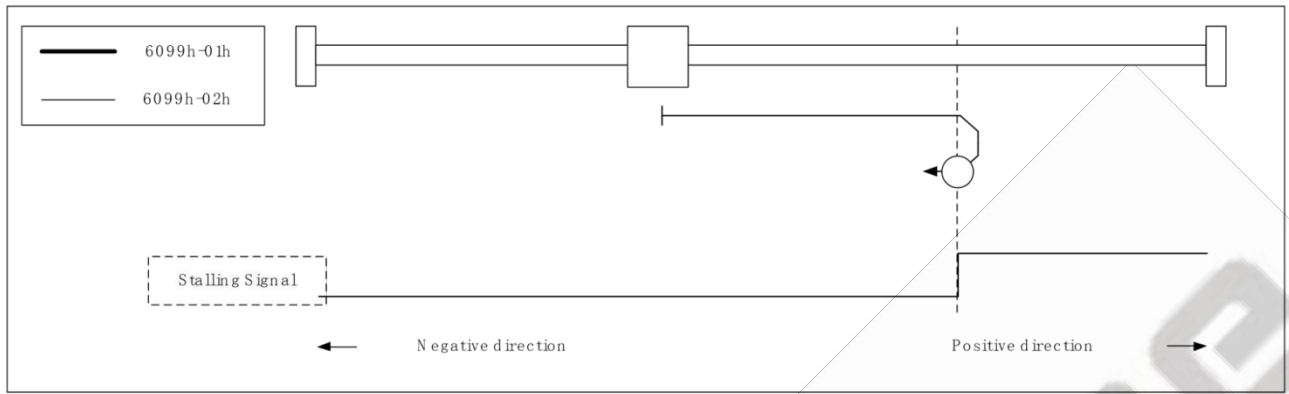

Method -3

- **Method -4 requires Stalling Signal.**

During the motor running in negative direction, when reaching the stalling signal, it will slow down and stop, then run in reverse, at last stops. (stop position as the zero position)

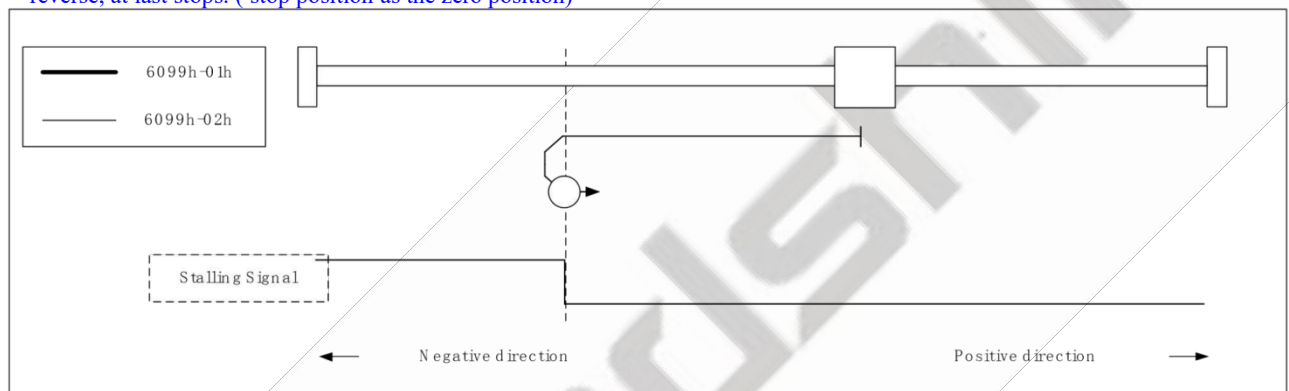

Method -4

- **Method -5 requires Stalling Signal.**

During the motor running in positive direction, when reaching the stalling signal, it will stop immediately. (Stalling Signal as the zero position)

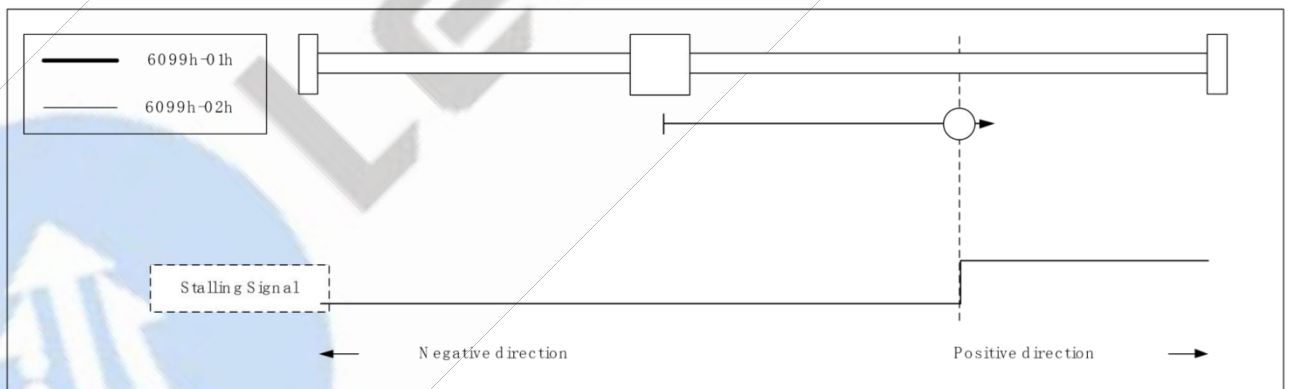

Method -5

- **Method -6 requires Stalling Signal.**

During the motor running in negative direction, when reaching the stalling signal, it will stop immediately. (Stalling Signal as the zero position)

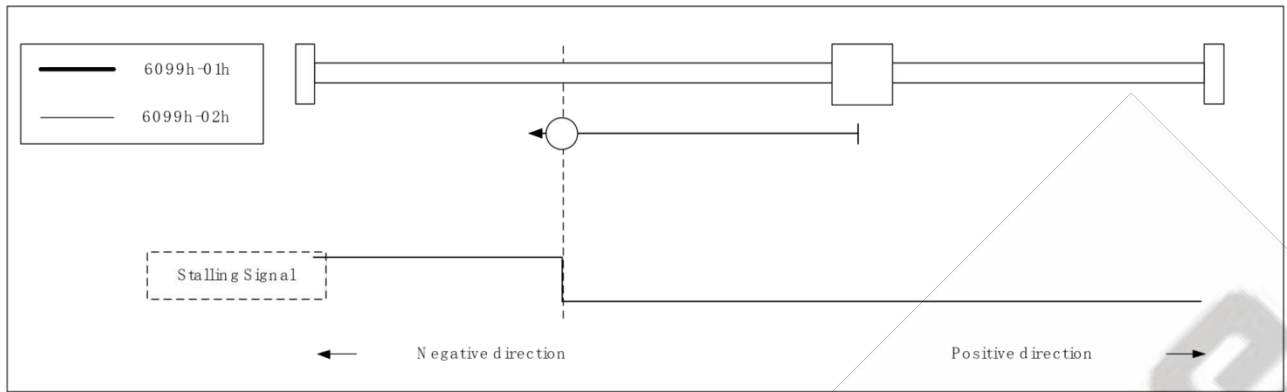

Method -6

- **Method 1 requires Z signal and Negative Limit.**

The load is located on the right side of the negative limit switch, and the motor running in negative direction. When reaching the negative limit signal, it will slow down and stop, then run in reverse, at last stops immediately when reaching the first Z signal. (Z signal as the zero position)

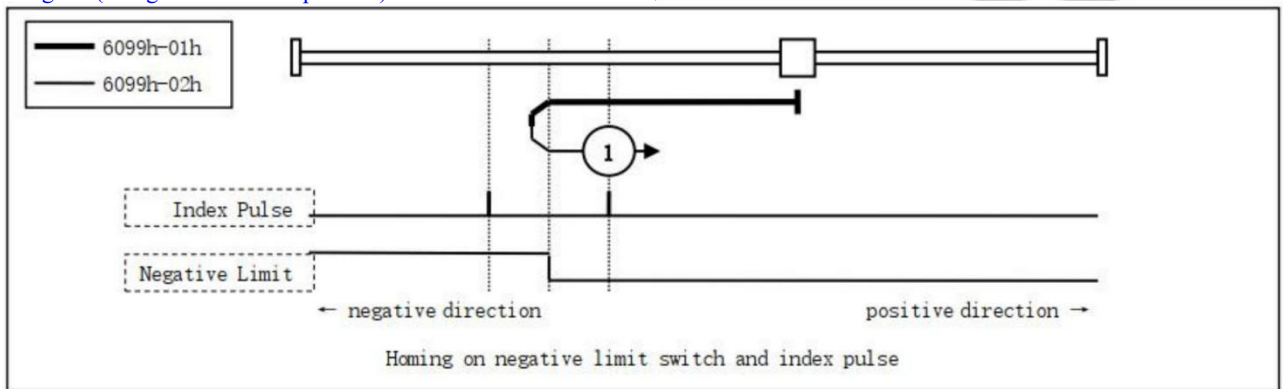

Method 1

- **Method 2 requires Z signal and Negative Limit.**

The load is located on the left side of the positive limit switch, and the motor running in positive direction. When reaching the positive limit signal, it will slow down and stop, then run in reverse, at last stops immediately when reaching the first Z signal. (Z signal as the zero position)

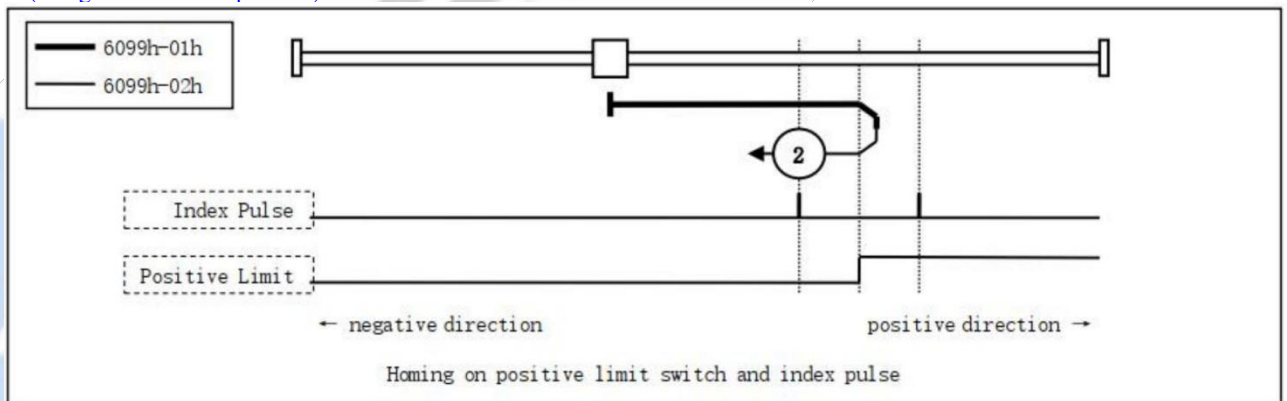

Method 2

- Method 3, 4, 5, 6 require Z signal and Home Switch

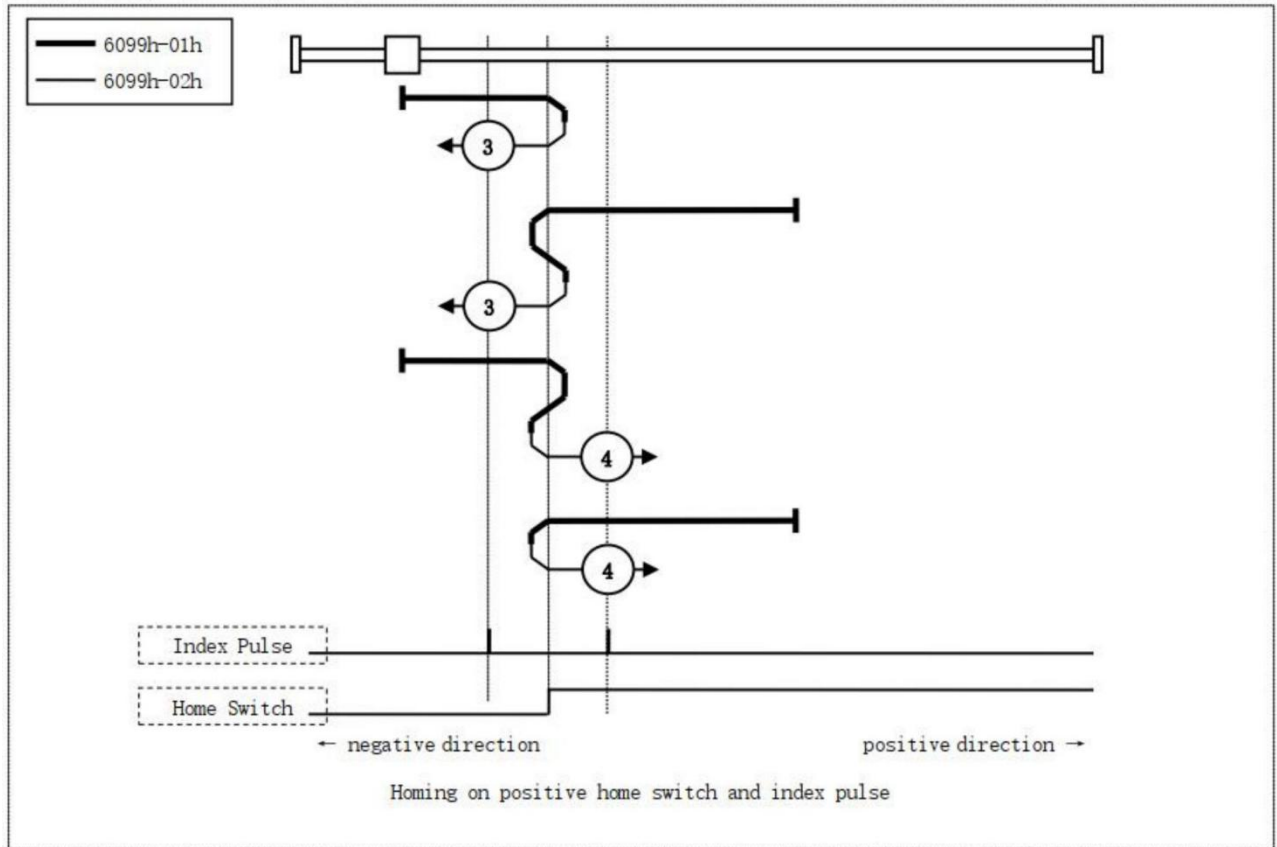

Method 3 & 4

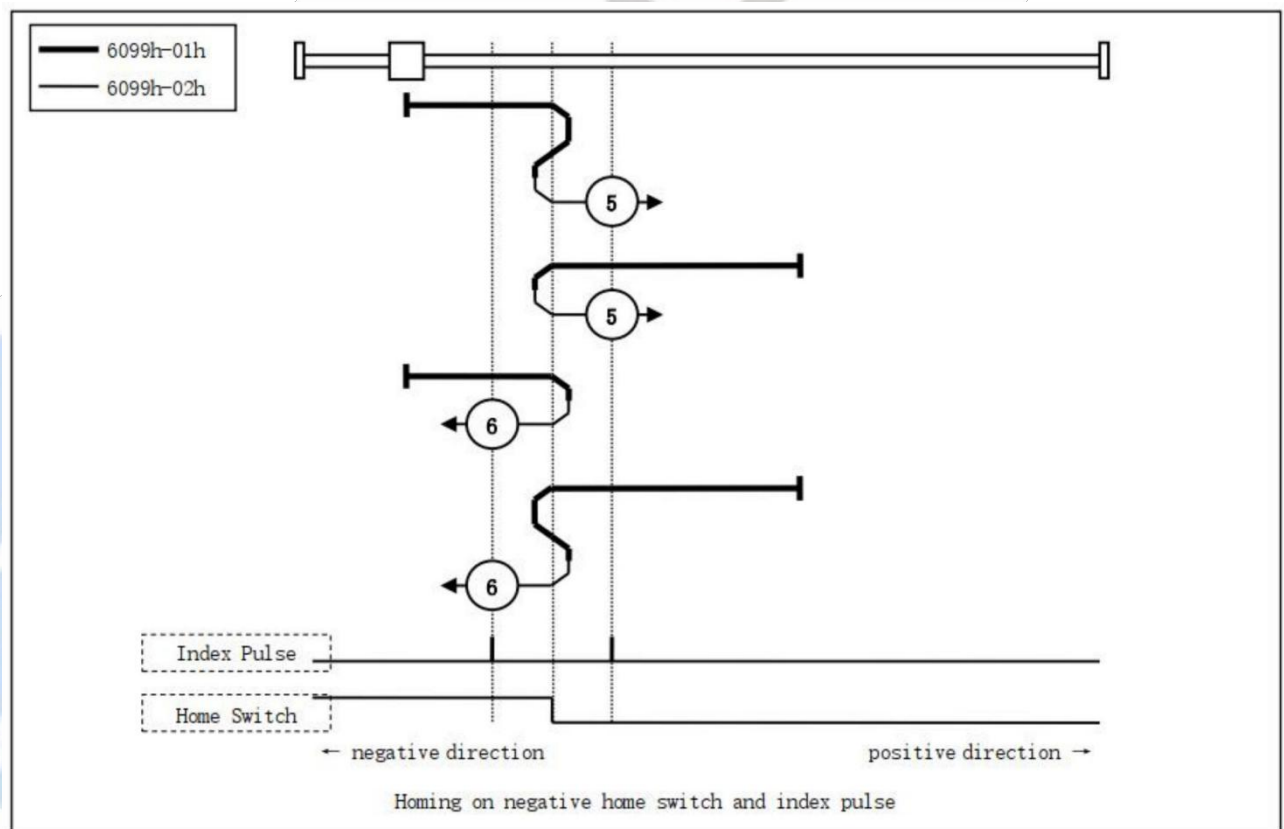

Method 5 & 6

- **Method 17 requires negative limit switch, and method 18 requires positive limit switch.**

The load is located on the right side of the negative limit switch, and the motor running in negative direction. When the motor reaching the negative limit signal for the first time, it will slow down and stop, then run in reverse, at last stops immediately when reaching the negative limit signal for the second time.

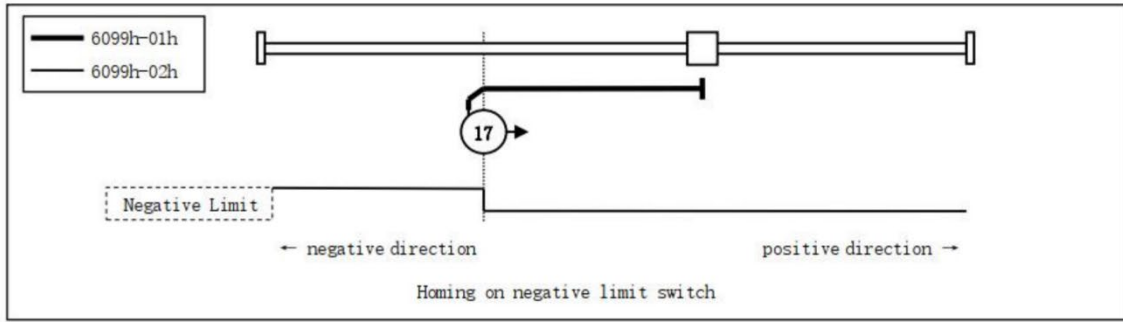

Method 17

- **Method 18 requires positive limit switch.**

The load is located on the left side of the positive limit switch, and the motor running in positive direction. When the motor reaching the positive limit signal for the first time, it will slow down and stop, then run in reverse, at last stops immediately when reaching the positive limit signal for the second time.

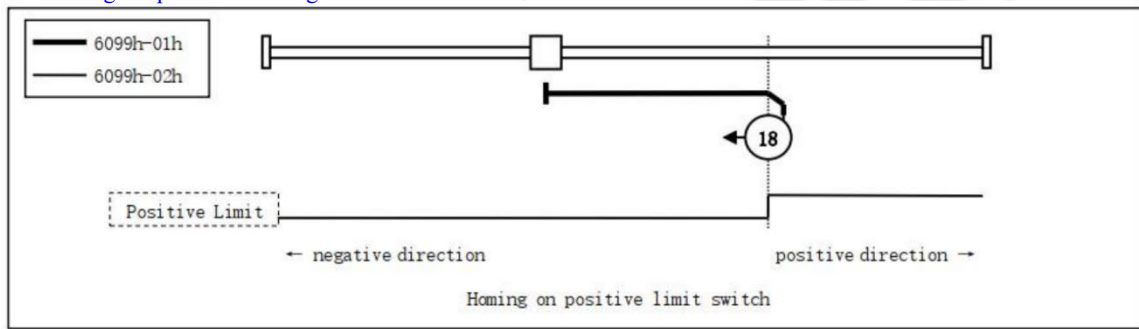

Method 18

- **Method 19, 20, 21, 22 require home switch**

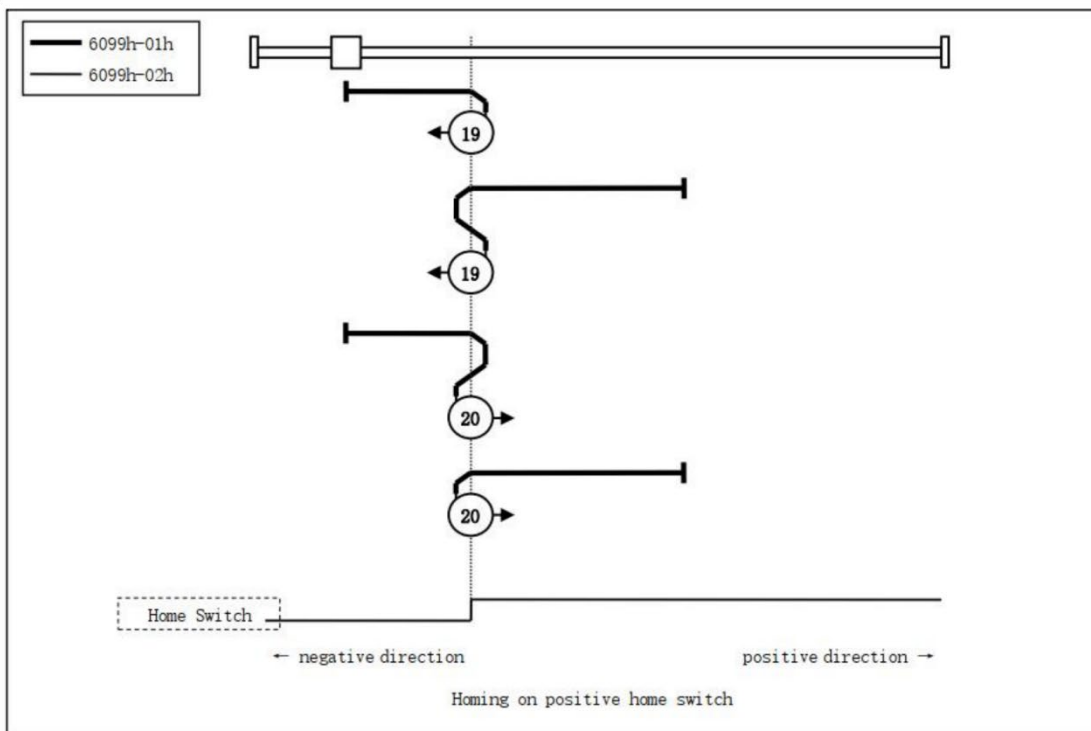

Method 19 & 20

- **Method 21 & 22 Description: The load is located on the home switch**

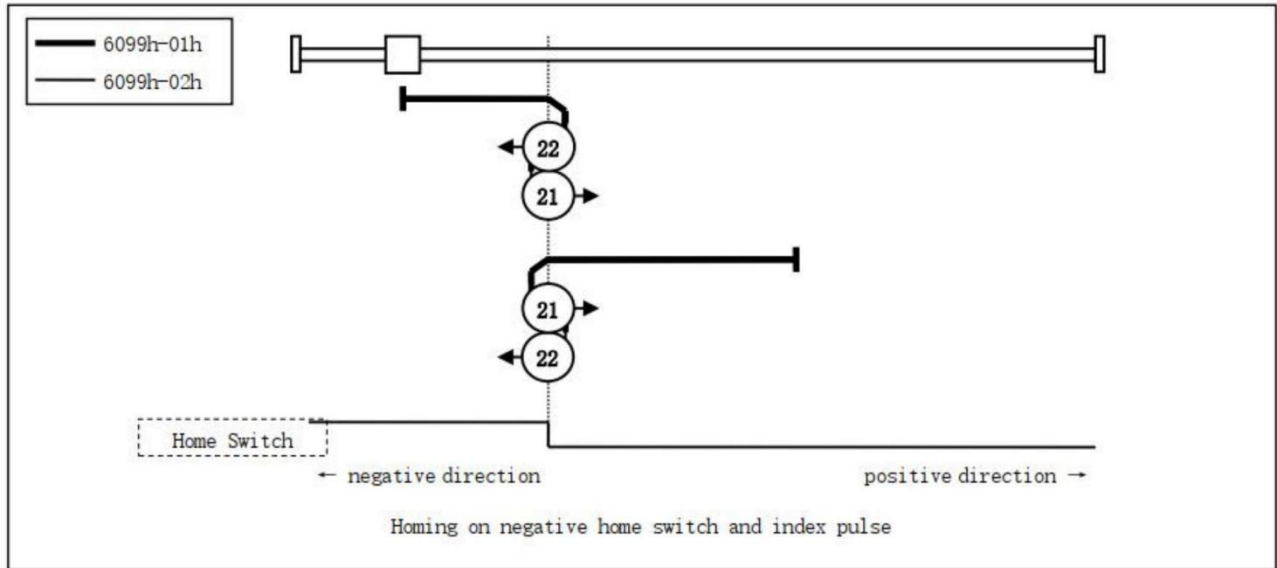

Method 21 & 22

- Method 23, 24, 25, 26 require the home switch and positive limit switch.

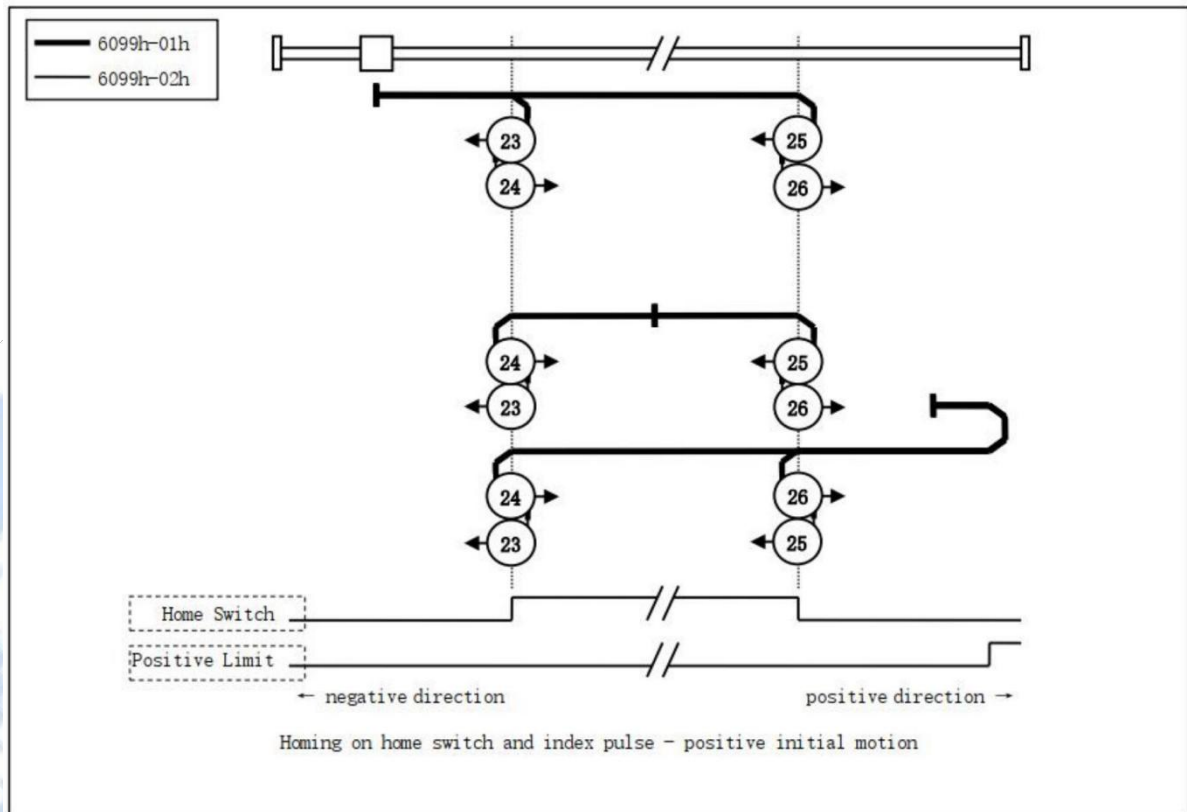

Method 23 & 24 & 25 & 26

- Method 27, 28, 29, 30 require the home switch and negative limit switch.

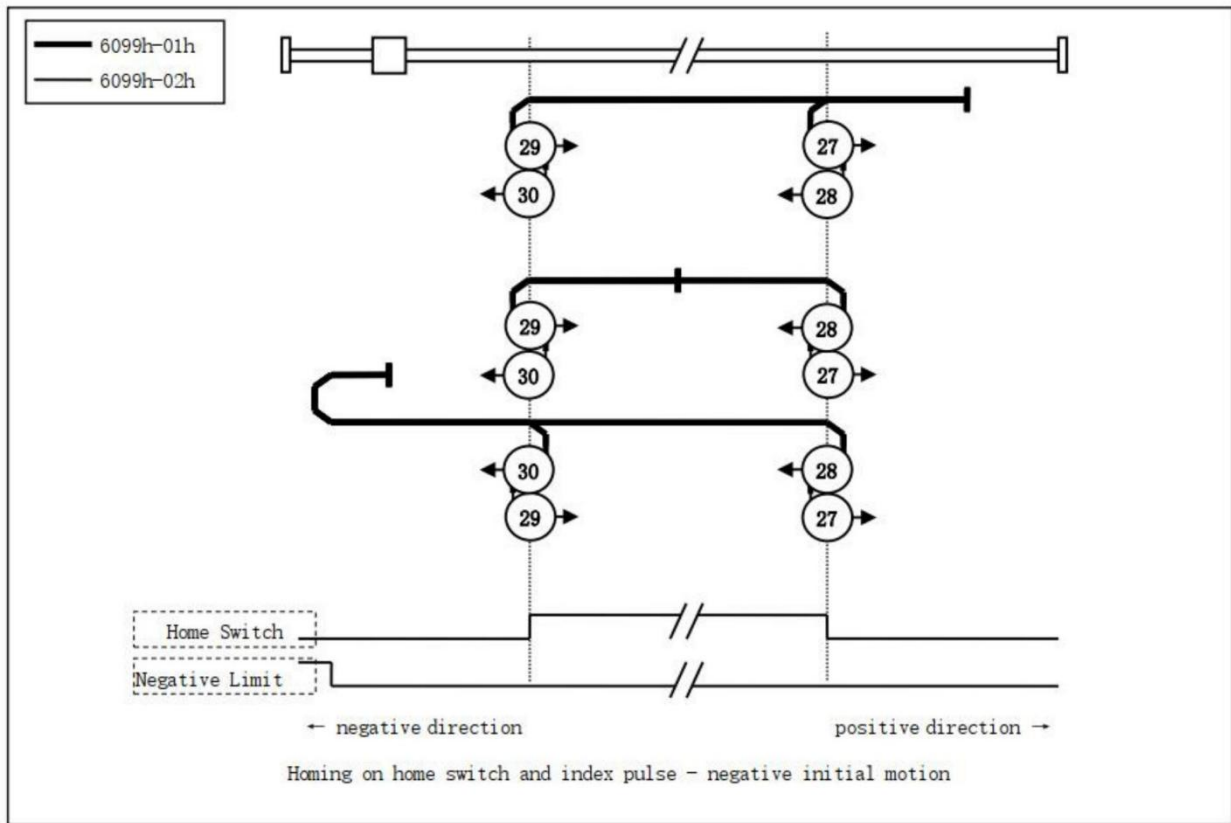

Method 27, 28, 29, 30

- Method 35 & 37 use the current position as the zero position, preferred method 37

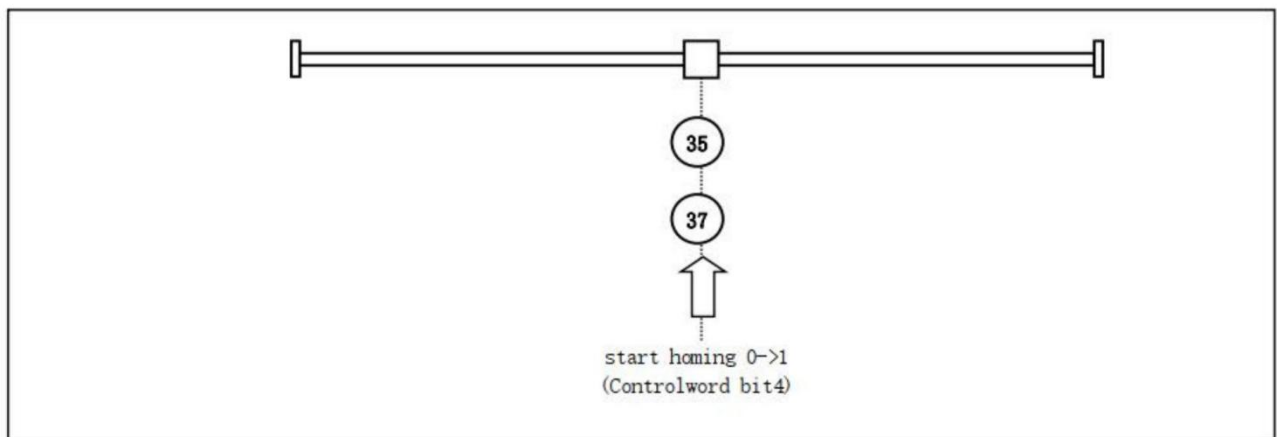

Method 35 & 37

Appendix B: Object Dictionaries

Index	Sub-index	Name	Access	Type	Range	Default Value	Unit	Remark
1000	0	Device type	R	UINT	0-32767	0x40912	-	Refer to CIA 402 profile
1001	0	Error register	R	USINT	0-255	0	--	Refer to Chapter 5. 1
1008	0	Device name	R	UINT	0-32767	CL3C-X	-	-
1010	00	Number of sub-index	R	UINT	0-32767	4	-	-
	01	Save all parameters	R/W	UDINT	0-0xFFFFFFFF	0	-	Need to write 0x65766173 or 1702257011 (decimal) into sub-index. It will return 1 if save successfully
	02	Save communication parameters	R/W	UDINT	0-0xFFFFFFFF	0	-	
	03	Save motion parameters	R/W	UDINT	0-0xFFFFFFFF	0	-	
	04	Save factory parameters	R/W	UDINT	0-0xFFFFFFFF	0	-	
1011	00	Number of sub-index	R	UINT	0-32767	4	-	-
	01	Restore all parameters to default setting	R/W	UDINT	0-0xFFFFFFFF	0	-	Need to write 0x64616f6c or 1684107116 (decimal) into sub-index. It will return 1 if save successfully
	02	Reset communication parameters to factory setting	R/W	UDINT	0-0xFFFFFFFF	0	-	
	03	Reset motion parameters to factory setting	R/W	UDINT	0-0xFFFFFFFF	0	-	
	04	Reset user parameters to factory setting	R/W	UDINT	0-0xFFFFFFFF	0	-	
1018	00	Number of sub-index	R	UINT	0-32767	4	-	-
	01	Vendor ID	R	UINT	0-32767	4321	-	Leadshine code
	02	Product code	R	UINT	0-32767	8X00	-	-
	03	Revision number	R	UINT	0-32767	1	-	-
	04	Series number	R	UINT	0-32767	1	-	-
1600	0	Number of sub-index	R/W	UINT	0-32767	3	-	Default number of 1 st mapping object
	01-08	1 st RXPDO-Map object	R/W	UDINT	0-0xFFFFFFFF	-	-	Default number of 1 st RXPDO-Map object
1601	0	Number of sub-index	R/W	UINT	0-32767	6	-	Default number of 2 nd mapping object
	01-08	2 nd RXPDO-Map object	R/W	UDINT	0-0xFFFFFFFF	-	-	Default number of 2 nd RXPDO-Map object
1602	0	Number of sub-index	R/W	UINT	0-32767	5	-	Default number of 3 rd mapping object
	01-08	2 nd RXPDO-Map object	R/W	UDINT	0-0xFFFFFFFF	-	-	Default number of 3 rd RXPDO-Map object
1603	0	Number of sub-index	R/W	UINT	0-32767	7	-	Default number of 4 th mapping object
	01-08	3 rd RXPDO-Map object	R/W	UDINT	0-0xFFFFFFFF	-	-	Default number of 4 th RXPDO-Map object
1A00	0	Number of sub-index	R/W	UINT	0-32767	7	-	Default number of 1 st mapping object

	01-08	1 st TXPDO-Map object	R/W	UDINT	0-0xFFFFFFFF	-	-	Default number of 1 st TXPDO-Map object
1A01	0	Number of sub-index	R/W	UINT	0-32767	0	-	Default number of 2 nd mapping object
	01-08	2 nd TXPDO-Map object	R/W	UDINT	0-0xFFFFFFFF	-	-	Default number of 2 nd TXPDO-Map object
1C00	0	Number of sub-index	R	UINT	0-32767	4	-	-
	01	Output type of email	R	UINT	0-32767	1	-	-
	02	Input type of email	R	UINT	0-32767	2	-	-
	03	Output type of process data	R	UINT	0-32767	3	-	-
	04	Input type of process data	R	UINT	0-32767	4	-	-
1C12	0-04	RXPDO assign	R/W	UINT	0-32767	1600	-	-
1C13	0-02	TXPDO assign	R/W	UINT	0-32767	1A00	-	-
1C32	0-0A	RXPDO administrative parameters	R	UINT	0-32767	-	-	-
1C33	0-0A	TXPDO administrative parameters	R	UINT	0-32767	-	-	-

Index	Sub-index	Name	Access	Type	Range	Default value	Unit	Remark
2000	00	Peak current	R/W/S	DINT	1-100	60	0.1A	Drive's max output current. 2CS3EIP-D507 is 60 by default.
2800	00							
2001	00	Microstep resolution	R/W/S	DINT	200-51200	10000	Pulse	Required number of pulse to rotate 1 revolution of motor. But it is recommended to modify via 6092+01
2801	00							
2010	01	Internal filtering time	R/W/S	UINT	0-32767	100	0.1ms	Internal smoothing time for control command.
2810	01							
2012	00	Soft-starting time	R/W/S	UINT	10-3000	1	ms	Internal smoothing time for starting current.
2812	00							
2013	00	Auto-tuning at power on	R/W/S	UINT	0-2	1	--	1: Yes. 0: No
2813	00							
2019	01	In-position pulse compensation	R/W/S	UINT	0-1	1	--	0: With compensation, the value of 6064 = 607A in position; 1: Without compensation
2819	01							
2019	02	In-position mode at disabled state	R/W/S	UINT	0-1	0	--	0: Not allowed in-position signal output when disabled; 1: Allowed in-position signal output when disabled;
2819	02							
201A	01	Locking current percentage of power on	R/W/S	UINT	0-100	100	%	Usually keep the default value.
281A	01							
201A	02	Closed loop holding current percentage	R/W/S	UINT	0-100	50	%	Multiply by the value of object 0x2000, the drive output current will change between these according to the load.
281A	02							
201B	00	Locking duration time	R/W/S	UINT	0-1500	200	ms	Appropriately reduce this value if you want to shorten the time of locking shaft.
281B	00							
201C	00	Max time to close brake	R/W/S	UINT	100-10000	1000	ms	Usually keep the default value
281C	00							
201D	00	Zero speed point	R/W/S	UINT	0-500	10	0.1r/s	-

281D	00							
2024	00	Control Mode	R/W/S	UINT	0~10	2	--	0: Open Loop Control; 2: Closed Loop Control
2824	00							
2025	01	Speed point for open loop switching closed loop	R/W/S	UINT	0~200	18	0.1r/s	-
2825	01							
2025	02	Delay for open loop switching closed loop	R/W/S	UINT	0~32767	12	ms	-
2825	02							
2025	03	Speed point for closed loop switching open loop	R/W/S	UINT	0~200	5	0.1r/s	-
2825	03							
2025	04	Delay for closed loop switching open loop	R/W/S	UINT	0~32767	250	ms	-
2825	04							
2025	05	Feedback speed point for closed loop switching open loop	R/W/S	UINT	0~200	50	0.1r/s	-
2825	05							
2029	00	Encoder resolution	R/W/S	UINT	4000-20000	4000	Count	4 times the encoder resolution. But it is recommended to modify by 0x608F+01
2829	00							
2030	00	Allowed max position following error pulses	R/W/S	UINT	0~32767	4000	Count	4000 indicates the error of one turn
2830	00							
2032	00	Distance to send "In Position" output signal	R/W/S	UINT	0-1000	4	Pulse	-
2832	00							
2033	00	Delay of in-position error de-jitter	R/W/S	UINT	0-1000	3	ms	-
2833	00							
2047	00	Over voltage point	R	UINT	0-1000	75	V	-
2847	00							
2048	00	Bus-voltage	R	UINT	0-65535	-	V	-
2848	00							
2051	00	Motor running direction	R/W	DINT	0-1	0	--	0: CCW direction 1: CW direction But it is recommended to modify by 0x607E
2851	00							
2056	00	Alarm detection selection	R/W/S	DINT	0~65535	65535	--	Bit setting: = 1: Yes; =0: No Bit0: over-current (invalid) Bit1: over-voltage Bit2: Position following error Bit3: Encoder wiring error Bit4: over speed alarm
2856	00							
2057	00	Reset alarm	R/W/S	UINT	0~65535	0	--	Write value 1 to clear the alarm. But it is recommended to write value 128(Decimal) to 0x6040
2857	00							
2090	01	Current loop Kp	R/W	DINT	0~32767	1500	--	--
2890	01							
2090	02	Current loop Ki	R/W	DINT	0~32767	300	--	--
2890	02							
2090	03	Current loop Kc	R/W	DINT	0~32767	300	--	--
2890	03							
2091	01	Speed Loop Kp	R/W	UINT	0~10000	25	-	
2891	01							
2091	02	Speed Loop Ki	R/W	UINT	0~10000	3	-	
2891	02							
2092	01	Position Loop Kp	R/W	UINT	0~100	25	-	
2892	01							
2150	00	Slave ID	R/W/S	UINT	0-256	1	--	Valid when 0x2151= 1;
2151	00	Slave ID resource	R/W/S	UINT	0-10	0	--	0: DIP switches 1: Setting by 0x2150 2: ESC
2232	00	Synchronous compensation1	R/W	DINT	0~65535	2	--	--
2A32	00							
2233	00	Synchronous compensation2	R/W	DINT	0~65535	100	--	--
2A33	00							
225C	00	Special function register	R/W	DINT	0~32767	0	--	Bit1= 1: Set motor running direction by 0x607E Bit2= 1: Set virtual input by 0x5012-03
2A5C	00							
22A9	00	Limit Mode	R/W	DINT	0-10	0	--	0: Stop normally 1: Invalid 2: Alarm, error code 260
2AA9	00							
22B4	00	Quick stop selection	R/W	DINT	0~32767	0	--	0: Alarm, error code 570, 1: Refer to 0x605A
2AB4	00							

3100	01	Control software version	R	UINT			--							
	02	Firmware version	R	UINT			--							
	03	EtherNet/IP protocol version	R	UINT			--							
3FFE	01-0B	Alarm record	R	USINT	0~32767		--	0x3FFE+01 is the current error code (current alarm) or the most recent error code (currently no alarm); 0x3FFE+02-0E are followed by the historical error code.						
47FE	01-0B													
4003	01	Delay of closing brake	R/W/S	UINT	0-1500	250	ms							
4803	01													
4003	02	Delay of loosening brake	R/W/S	UINT	0-1500	250	ms							
4803	02													
4003	03	Max speed to close brake	R/W/S	UINT	0-500	10	0.1r/s							
4803	03													
5000	03	Internal enable state	R	UINT	0~32767		--	0: Disabled 1: Enabled						
5800	03													
5000	04													
5800	04	Reach the target state	R	UINT	0~32767		--	Bit0=0: Not reach Bit0=1: Reach Bit1=0: No stall Bit1=1: Stalled						
5002	01	ESC ID	R/W	UINT	0~32767	0	--	Write 0, return the ID data in ESC to 0x5002-02; Write 0x12, return the current ID setting by DIP switches						
5802	01													
5002	02	ESC data	R	UINT	0~32767	408	--	Return Node ID data						
5802	02													
5004	0F	Sync0 Synchronization interface parameters	R/W	UINT	0~32767		--	Bit0 =1: RPDO mapping can't be written by SDO; Bit0 =0: RPDO mapping can be written by SDO; Bit1 = 1: Detect the number of PDO mapping; Bit1=1: Don't detect the number of PDO mapping; Bit2= 1 : Send 0xF directly to enable; Bit2=0: Send 0xF can't be enabled.						
5804	0F													
5005	00	DC compensation base value	R/W	UINT	0~32767	500	--	--						
5805	00													
5006	00	Synchronization error detection	R/W	UINT	0~32767	0	--	--						
5806	00													
5011	00	Internal actual location	R	UDINT	0~32767		--	--						
5811	00													
5012	01	Homing arrival position	R/W	DINT	0~32767	0	--	--						
5812	01													
5012	02	Homing trigger position	R/W	DINT	0~32767	0	--	--						
5812	02													
5012	03	Homing virtual input	R/W	UDINT	0~32767	0	--	When 0x225C=4, activate the virtual input function; 60FD different bits, corresponding to different virtual inputs;						
5812	03							<table border="1"> <thead> <tr> <th>Inputs</th> <th>Bit of 60FD</th> </tr> </thead> <tbody> <tr> <td>Probe signal 1</td> <td>Bit 26= 1</td> </tr> <tr> <td>Home switch</td> <td>Bit 2= 1</td> </tr> <tr> <td>Positive limit</td> <td>Bit 1= 1</td> </tr> <tr> <td>Negative limit</td> <td>Bit 0= 1</td> </tr> <tr> <td>Z signal (index signal)</td> <td>Bit 31= 1</td> </tr> </tbody> </table>	Inputs	Bit of 60FD	Probe signal 1	Bit 26= 1	Home switch	Bit 2= 1
Inputs	Bit of 60FD													
Probe signal 1	Bit 26= 1													
Home switch	Bit 2= 1													
Positive limit	Bit 1= 1													
Negative limit	Bit 0= 1													
Z signal (index signal)	Bit 31= 1													
5012	04	Homing setting	R/W	UINT	0~32767	5	--	Bit0=0: Homing protection is not turned on; Bit0= 1: Homing protection is turned on; (Homing protection: when start homing, If the limit signal takes effect, bit0=0 means homing normally, bit0=1 means stop						

5812	04							homing as limit protection) Bit2=0: The value of current position after in position = 0x607C; Bit2= 1: The value of 0x607C is used as the motion offset, and finally 0x6064 = 0; Bit3=0: 0x6064= 0x607C after in position; Bit3= 1: 0x6064 = 0x607C after in position;
5400	01	Minimum synchronization period	R/W	UINT	250~2000	250	us	--
5C00	01							
5400	02	Maximum synchronization period	R/W	UINT	250~20000	10000	us	--
5C00	02							
5503	04	Special function register	R/W	UINT	0~65535	2	--	Bit0 = 0: Asynchronous mode, the host will track 0x607A-00 in real time; Bit0= 1: Asynchronous mode, the host does not track 0x607A-00in real time.
5D03	04							





Index	Sub-index	Name	Access	Type	Range	Default value	Unit	Remark
2152	01	Input1 function	R/W/S	DINT	0-65535	0x17 (Decimal 23)	--	Default is touch probe1, take effect changes need restart power
2952	01							
2152	02	Input2 function	R/W/S	DINT	0-65535	0x18 (Decimal 24)	--	Default is HOME, take effect changes need restart power
2952	02							
2152	03	Input3 function	R/W/S	DINT	0-65535	0x16 (Decimal 22)	--	Default is POT, take effect changes need restart power
2952	03							
2152	04	Input4 function	R/W/S	DINT	0-65535	0x01 (Decimal 1)	--	Default is NOT, take effect changes need restart power
2952	04							
2156	01	Output1 function	R/W/S	DINT	0-65535	0x01	--	Default is alarm output, take effect changes need restart power
2956	01							
2156	02	Output2 function	R/W/S	DINT	0-65535	0x04	--	Default is brake output, take effect changes need restart power
2956	02							

Index	Name	Access	Type	Range	Default value	Unit	Remark
603F	Error code	R	UINT	0-65535	0	--	Refer to chapter 5.2
683F							
6040	Control word	R/W	UINT	0-65535	0	--	Refer to chapter 6.1
6840							
6041	Status word	R	UINT	0-65535	0	--	Refer to chapter 6.1
6841							
605A	Quick stop type selection	R/W	UINT	0-65535	6	--	0: After stopping immediately, switch on disable state; 1: After decelerating to stops at a speed value of 0x6084, switch on disable state; 2: After decelerating to stops at a speed value of 0x6085, switch on disable state; 3: After decelerating to stops at a speed value of 0x60C6, switch on disable state; 4: After stopping immediately, switch on quick stop state; 5: After decelerating to stops at a speed value of 0x6084, switch on quick stop state; 6: After decelerating to stops at a speed value of 0x6085, switch on quick stop state; 7: After decelerating to stops at a speed value of 0x60C6, switch on quick stop state;
685A							
605D	Asynchronous mode halt selection	R/W	INT	0~65535	1	--	1: After decelerating to stops at a speed value of 0x6084, keep operation enable state; 2: After decelerating to stops at a speed value of 0x6085, keep operation enable state; 3: After decelerating to stops at a speed value of 0x60C6, keep operation enable state; 4: After stopping immediately, keep operation enable state.
685D							

6060	Operation mode	R/W	USINT	0-255	8	--	1: PP mode, 3: PV mode, 6: Home mode,
6860							
6061	Operation mode display	R	USINT	0-255	8	--	-
6861							
6062	Position command	R	DINT	-2147483648 ~2147483647	0	Pulse	-
6862							
6064	Position actual value	R	DINT	-2147483648 ~2147483647	0	Pulse	-
6864							
6067	Distance to send "In Position" output signal	R/W/S	UINT	0-1000	4	Pulse	It is recommended to use this object in preference, Can also set by 0x2032,
6867							
606B	Velocity command	R	DINT	-2147483648 ~2147483647	0	P/s	-
686B							
606C	Velocity actual value	R	DINT	-2147483648 ~2147483647	0	P/S	-
686C							
607A	Target position	R/W	DINT	-2147483648 ~2147483647	0	P	Target position under PP mode
687A							
607C	Home offset	R/W	DINT	-2147483648 ~2147483647	0	P	The value of difference between zero position and mechanical zero point under Homing mode . If the value is set to10000, it means that at homing mode 19, the motor reaches the Home switch and stops immediately, then reverses at low speed until it leaves the Home switch, at last stops at a distance of 10000P.
687C							
607D+01	Software negative limit	R/W	DINT	-2147483648 ~2147483647	0	P	New target positions are checked against these limits. The limits are relative to the machine home position, which is the result of homing. As default the software position limits are switched off. Changed values must be saved and the drive must be restarted to take enable the new the software limits.
687D+01							
607D+02	Software positive limit	R/W	DINT	-2147483648 ~2147483647	0	P	
687D+02							
607E	Motor direction	R/W	USINT	0~255	0	--	Need to set 0x225C first
687E							
60FF	Target velocity	R/W	DINT	-2147483648 ~2147483647	0	P/S	Profile velocity under PV mode
68FF							
6080	Max velocity limit	R/W/S	UDINT	-2147483648 ~2147483647	3000	rpm	-
6880							
6081	Max profile velocity	R/W/S	DINT	-2147483648 ~2147483647	50000	--	Max. Allowable velocity under PP mode
6881							
6082	Start velocity	R/W/S	DINT	-2147483648 ~2147483647	0	--	Start velocity under PP mode
6882							
6083	Profile acceleration	R/W/S	DINT	-2147483648 ~2147483647	4000	P/S^2	Acceleration under PP and PV mode
6883							
6084	Profile deceleration	R/W/S	DINT	-2147483648 ~2147483647	4000	P/S^2	Deceleration under PP and PV mode
6884							
6085	Quick stop deceleration	R/W/S	DINT	-2147483648 ~2147483647	400000000	P/S^2	Deceleration of quick stop under PP, PV and Home mode
6885							
608F+01	Encoder resolution	R/W/S	UINT	4000-20000	4000	Count	It is recommended to use this object in preference, can also set by 0x2029,
688F+01							
6092+01	Microstep resolution	R/W/S	DINT	200-51200	10000	Pulse	It is recommended to use this object in preference,can also be modified via 0x2001,
6892+01							
6098	Homing method	R/W/S	USINT	1-100	19	-	Methods of searching zero position under homing mode, refer to Appendix A
6898							
6099+01	Fast homing velocity	R/W/S	DINT	-2147483648 ~2147483647	50000	P/S	Speed during search for limit switch signal
6899+01							
6099+02	Slow homing	R/W/S	DINT	-2147483648	25000	P/S	Speed during search for Home switch

6899+02	velocity			~2147483647			
607C	Home offset	R/W/S	DINT	-2147483648	0	p	The value of difference between zero position and mechanical zero point under Homing mode
687C				~2147483647			
609A	Homing acceleration	R/W/S	USINT	-2147483648	25000	P/S^2	Acc / Dec velocity under Home mode
689A				~2147483647			
60B0	Position offset	R/W	DINT	-2147483648	0	P	Position offset under PP mode
68B0				~2147483647			
60B8	Touch probe control word	R/W	UINT	0-65535	0	-	Set touch probe function, refer to chapter 6.3
68B8							
60B9	Touch probe statue word	R	UINT	0-65535	0	-	Status of touch probe 1/2, refer to chapter 6.3
68B9							
60BA	Touch probe 1 positive value	R	DINT	-2147483648	0	P	Data value sensed by touch probe 1 at rising edge
68BA				~2147483647			
60BB	Touch probe 1 negative value	R	DINT	-2147483648	0	P	Data value sensed by touch probe 1 at falling edge
68BB				~2147483647			
60BC	Touch probe 2 positive value	R	DINT	-2147483648	0	P	Data value sensed by touch probe 2 at rising edge
68BC				~2147483647			
60BD	Touch probe 2 negative value	R	DINT	-2147483648	0	P	Data value sensed by touch probe 2 at falling edge
68BD				~2147483647			
60C2+01	Interpolation time period value	R/W	USINT	0-255	2	--	Only for internal tuning.
68C2+01							
60C2+02	Interpolation time unit	R/W	SINT	-128-127	0	--	
68C2+02							
60D5	Touch probe 1 rising edge counter	R	UINT	0-65535	0	--	Frequency for capture of touch probe 1 rising edge
68D5							
60D6	Touch probe 1 falling edge counter	R	UINT	0-65535	0	--	Frequency for capture of touch probe 1 falling edge
68D6							
60D7	Touch probe2 rising edge counter	R	UINT	0-65535	0	--	Frequency for capture of touch probe 2 rising edge
68D7							
60D8	Touch probe 2 falling edge counter	R	UINT	0-65535	0	--	Frequency for capture of touch probe 2 falling edge
68D8							
60FD	Digital input statue	R	UDINT	0- 4294967296	0	--	Statue of digital input signals, refer to chapter 4.3. 1
68FD							
60FE+01	Open physical output	R/W/S	UDINT	0- 4294967296	0	--	Able to control user output through this object, refer to chapter 4.3.4
68FE+01							
60FE+02	Enable physical output	R/W/S	UDINT	0- 4294967296	0	--	
68FE+02							

Appendix C: Connectors

Pic	Description	Brand&Specification	Model	Number	Package Inside
	Power&Motor Connector for 2CS3EIP-D503, 2CS3EIP-D507	MOLEX 2PIN, 13A	39012020	1	No
		MOLEX 4PIN, 13A	39012040	1	No
		MOLEX	39000038	4	No
	Encoder Connector	MOLEX	513531200	1	No
		MOLEX	561349000	8	No
	I/O Connector	ANYTEK 2*11PIN, 3.5mm	NL22100200G0G	1	Yes

Note: For 2CS3EIP Series drives, motor connector and encoder connector are on the extension cable

Appendix D: FAQs

- **Communicate errors.**

- ▶ If it is the first time to use this EtherNet/IP drive, check whether the version of XML file is correct. Most masters support scanning slave, it is recommended to create configuration in scanning way.
- ▶ Some masters require the connection of the network cable according to the ECAT IN and ECAT OUT.
- ▶ Check whether the PDO synchronization period set by master and slave is the same.
- ▶ Some masters require DIP switches to be set to the same node ID as the configuration setting.
- ▶ The network cable is faulty or has poor contact, replace the cable. Or check the problem by swapping it with the network cable on a normally connected node.
- ▶ The EtherNet/IP drive is faulty, replace the cable. Or check the problem by swapping it with a normally worked drive.

- **Drive cannot be enabled**

- ▶ Check the status of the drive. Under normal conditions, the PWR green light of the driver is on for a long time and the ALM red light is off. The L/A green light of the ECAT IN and ECAT OUT network ports blinks rapidly, the run green light is on for a long time and the Err red light is off.
- ▶ PDO configuration or PDO mapping error. It needs to configure PDO or PDO mapping correctly.
- ▶ Check if the value of object 0x6040 is 16#F and if bit0~bit3 of object 0x6041 is 0111.
- ▶ Check the master for warnings or errors. Clear the master station alarm or warning.
- ▶ If the master station shows enable complete, but the motor is not enabled. Check whether the motor wire is connected wrongly or disconnected. Or check if the output current of drive is set correctly.

- **Alarm when send instruction to slave**

- ▶ Check the drive for alarms. Check if the drive ALM red light and ERR red light are flashing, if there is an alarm, check the drive instruction manual and locate the problem according to the alarm instructions.
- ▶ PDO configuration exception. Some masters need to check if the slave's object 0x6061 returns the correct value. If 0x6061 is not configured, the slave may not work or the master may alarm.
- ▶ The limit switch is activated. Check that the limit switch input is the same as the logic set by the master. Is the polarity of the slave input port the same as the limit switch used. The limit switch is not damaged. Whether the wiring between the limit switch and the slave is correct. The bit bit of object 0x60FD is mapped incorrectly with the master.

- **Motor does not turn**

- ▶ The controller instruction is not sent to the driver. Check if the value of 0x607A (Target position) has changed, if not, then maybe the program has an exception.
- ▶ Limit switch is activated. Check if the limit switch logic status is consistent with the set by the master. Or whether the polarity of the slave input port is consistent with the limit switch. Or whether the limit switch is damaged. Or whether the wiring between the limit switch and the slave is correct. Or the mapping between the bit of 0x60FD and the master is wrong.
- ▶ The control instruction is normal, but the motor does not turn. It may be that the output current setting is too small. Or the load is too heavy. Or the starting speed is too large. Or the acceleration time is too short. Or the motor is damaged. All of the above can be tested by letting the motor unload and setting the motor speed to 60rpm with acceleration time 200ms to check the problem.

- **Homing Error**

- ▶ Wrong homing method. There are three modes of homing, when using the master homing mode, the operation mode object 0x6060 = 8; when using the slave homing mode, the 0x6060 = 6; when using the master-slave combination homing method, the 0x6060 value is first 8 and then 6. Please check master

manufacturer for default homing mode, and then check the selected homing method, the relevant parameters are correct, and the limit switch needed in the selected homing method is normal.

▶ Stop on the limit switch and keep processing Busy state. Some master stations are master-slave combination homing mode (Panasonic and Keyence), the 0x6060 value is first 8 and then 6. If there is no configuration 0x6060 in PDO or wrong configuration, then will cause homing error.

- **Occasional dropouts during operation**

▶ Always a certain drive dropouts. Maybe network cable problem: Poor contact between network cable and drive interface. Or the OUT port of the last drive has a problem. Or the drive itself has problem. All of the above can be tested by swapping the drive or swapping the network cable.

▶ Random drive dropouts. Interference problem: Poor quality of network cable, it is recommended to use a Category 5 Fast Ethernet cable or above, industrial grade network cable with twisted pair shielding. Ensure that the equipment is well grounded. When laying out the electrical cabinet, strong and weak power need to be separated. Keep away from high power strong interference devices such as plasma generators, laser generators, VFD etc.